

Table of Contents Engineering Section

Introduction
Ball Bearings
Cylindrical Roller Bearings
Spherical Roller Bearings
Tapered Roller Bearings
Thrust Bearings
Split Pillow Blocks
Super Precision Bearings
Linear Motion
Rolling Mill Bearings
Engineering Section

ROLLING BEARINGS

Design and Classification299
Description and Features300

BEARING SELECTION

Selection Based on Basic Load Rating ..303
Equivalent Bearing Loads304
Correction of Basic Load Due to Temp. .304
Adjustments to Fatigue Life Rating305
Static Load Rating305
Selection Based On Dimensions305

BEARING IDENTIFICATION

Bearing Number Formulation306
Snap Ring and Groove Dimensions310

BEARING TOLERANCES

Bearing Tolerance Standards312
Bearing Tolerance Nomenclature313
Tolerances for Radial Bearings
(except Tapered)314
Tolerances for Metric Tapered Bearings .318
Tolerances for Inch Tapered Bearings ..322
Tolerances for Thrust Ball Bearings324
Tolerances for Thrust Spherical Bearings .326

BEARING FITS AND INTERNAL CLEARANCE

Fit-Why It's Important327
How to Select Proper Fit328
Bearing Internal Clearance330
Internal Clearance Tables330
Selection of Bearing Internal Clearance .333
Changes in Radial Internal Clearance ...334

PRELOADED BEARINGS

Why Preload?335
How to Preload Duplex Bearings335
Selecting Preloading Method336
Preload Tables337

BEARING LUBRICATION

Lubrication-The Purpose338
Selecting the Correct Methods338
Grease Lubrication338
Oil Lubrication339
Lubricants342

Bearing Installation, Maintenance and Inspection

How to Handle Bearings345
Mounting-Factors to Consider345
Inspecting and Trouble-shooting349
How to Dismount Bearings351
Cleaning, Inspection, and Evaluation ...353
Maintenance and Inspection353

APPENDICES

Shaft Diameter Tolerances356
Housing Tolerances358
Part Number Index360
Conversion Factors366

Rolling Bearings – Types and Features

Design and Classification

Rolling bearings use balls or other rolling elements, located between bearing rings, to minimize friction. The rolling elements are separated and held in position by "cages" or other retaining devices.

The construction of six of the most common rolling element bearings are illustrated here for identification of nomenclature. Specific dimensions and details for these bearings are given in the dimensional tables in the preceding sections of this catalog.

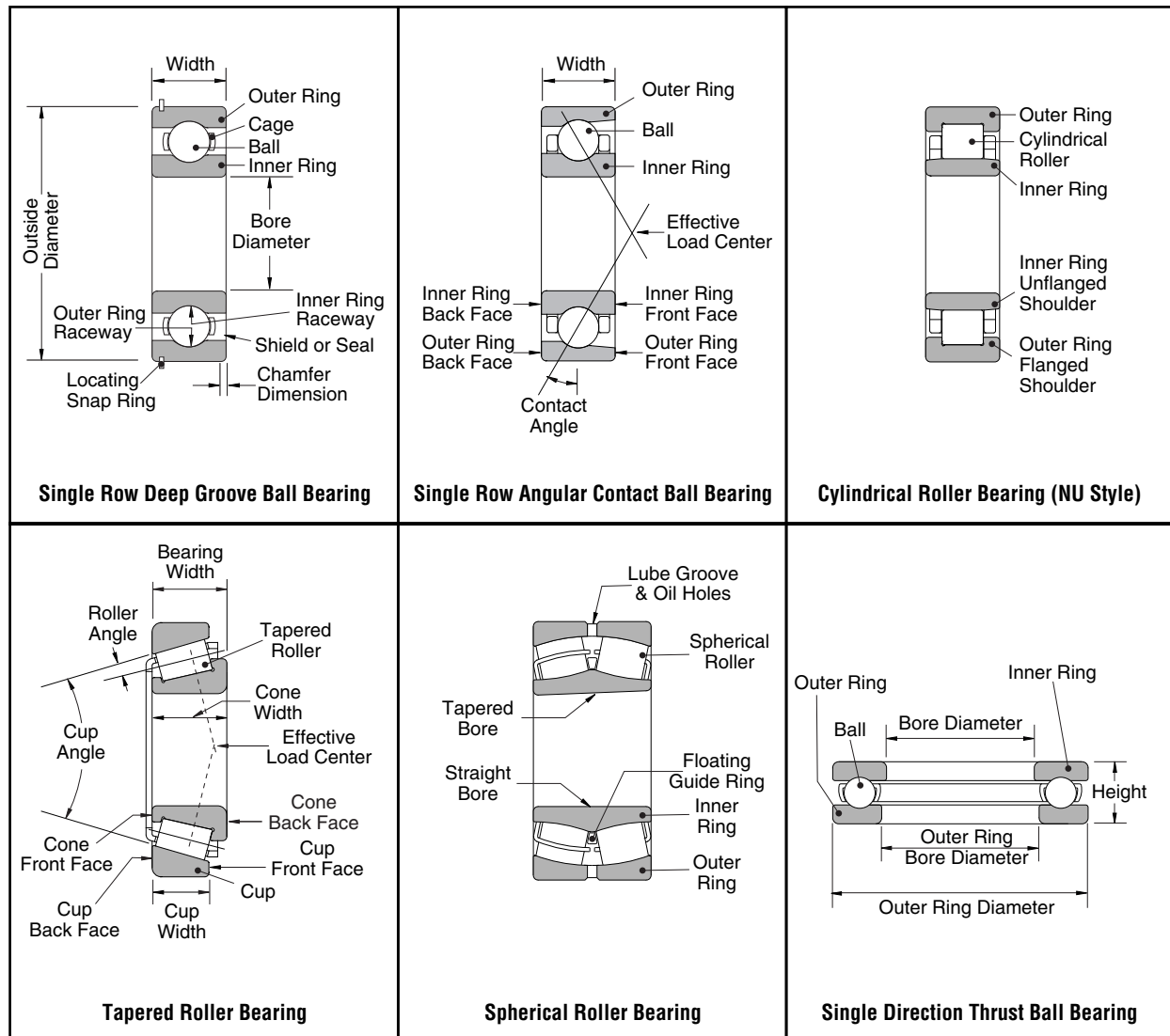

Figure 10.1 — Nomenclature for Bearing Components and Reference Dimensions.

Introduction

Ball Bearings

Cylindrical Roller Bearings

Spherical Roller Bearings

Tapered Roller Bearings

Thrust Bearings

Split Pillow Blocks

Super Precision Bearings

Linear Motion

Rolling Mill Bearings

Engineering Section

In comparison to plain or sleeve type bearings, rolling bearings offer several advantages:

- Starting torque is minimal and the difference between starting torque and running torque is small.
- Rolling bearings can be designed to take both radial and axial loads simultaneously or independently.
- Rolling bearings can be preloaded to produce a negative clearance. This gives the bearing greater rigidity to constrain the radial and axial movement of a shaft relative to its housing.

Depending on the shape of their rolling elements, bearings fall into two main classes--ball bearings and roller bearings. Roller bearings are further classified by the specific shape of their rollers and by other individual features.

Bearings are also classified by function. For example, they can be classified as "radial," "thrust" or both, depending on the direction of the applied load and may be further classified as cylindrical, tapered, spherical or duplex depending on their configuration.

Description and Features

Typical bearing configurations are described below:

Deep Groove Ball Bearings are the most common type of rolling element bearing. They have a single row of balls held in place by a cage, usually made of steel, that rotates between two rings with polished raceways. The design of the bearing allows for radial and axial loading while operating at high speeds. These bearings often come with shields or seals to protect the inside of the bearing from contamination in the application.



Double Row Ball Bearings have two rows of balls between two bearing rings. This is a back-to-back mounting of two single-row angular contact ball bearings, but their inner and outer rings are each integrated into one. This design allows for heavier axial loads in either direction and a significant radial load capacity. Some of these bearings are also available with shields and seals.



Self-Aligning Ball Bearings have an inner ring with two raceways. The outer ring has one spherical raceway and its center coincides with that of the bearing. Because of this, the axis of the inner ring, the balls and the cage can deflect around the bearing center. As a result, minor angular misalignment of the shaft, in relation to the bearing housing, can be accommodated. This type of bearing, with tapered bore, is often mounted using an adapter sleeve.



Cylindrical Roller Bearings have large radial load capacities. The rolling elements remain in linear contact with the bearing raceway and are precisely crowned to relieve the edge loading caused by shaft misalignment.



A cylindrical roller bearing in which either the inner or outer ring has no rib, may be used as free-end or floating bearing because its rings are free to move, in an axial direction, relative to each other. If either the inner or outer ring has two ribs and the other ring has one rib, the bearing is capable of taking a certain amount of axial load in one direction. Double row cylindrical roller bearings have high radial rigidity and are used primarily for precision machine tools.

Tapered Roller Bearings can take both radial and axial loads in one direction. They use conical rolling elements which are guided by ribs on the bearing's inner ring. The bearing rollers are precisely crowned near each end to relieve edge loading.



Since an axial force is generated in these bearings when a radial load is applied, they are often mounted in pairs, face to face, like single row angular contact ball bearings. When this is the case, the proper internal clearance can be obtained by adjusting the axial distance between the inner rings or outer rings of the two opposed bearings. Since they are separable, the inner and outer rings can be mounted independently.

Tapered roller bearings are divided into three types--normal, medium angle and steep angle--depending on the degree of contact angle. Double row tapered roller bearings are also available.

Spherical Roller Bearings are capable of handling both radial and axial loads in either direction and have excellent radial load carrying capacity. The line of contact between the barrel-shaped rollers and the outer ring raceway is a circular arc centered on the bearing axis. The outer ring raceway is spherical, making it self-aligning. There are two inner raceways and two rows of rollers.



Spherical roller bearings with tapered bores can be mounted directly on tapered shafts or on cylindrical shafts by using an adapter or withdrawal sleeve. Spherical roller bearings are available with pressed-steel, machined bronze or molded cages.

Duplex Bearing Set is a pair of radial bearings combined in various arrangements. It is often a combination of angular contact ball bearings or of tapered roller bearings. It may be a combination placed face to face (type DF) or back to back (type DB) or in tandem (type DT). Types DF and DB are capable of taking radial loads and axial loads in either direction. They may be modified to accommodate a variety of preloading requirements. Type DT is used when the application requires large axial loads in one direction.



Single Direction and Double Direction Thrust Ball Bearings are composed of washer-like bearing rings with raceway grooves for the balls. The ring attached to the shaft is called the inner ring or tight washer and the ring attached to the housing is called the outer ring or loose washer. In double direction thrust ball bearings there are three rings, with the center one fixed to the shaft.



Single direction thrust ball bearings can support axial loads in one direction; double direction, in two. There are also thrust ball bearings with an aligning seat washer beneath the outer ring to compensate for shaft misalignment or mounting errors.

Spherical Roller Thrust Bearings have a spherical raceway in the outer ring with the rollers obliquely arranged in a single row. Since the raceway in the outer ring is spherical, these bearings are self-aligning.



Spherical roller thrust bearings have a very high axial load capacity and are capable of taking moderate radial loads when an axial load is imposed. These bearings are suited for lower speeds and require oil for lubrication. They are assembled with pressed-steel cages or machined brass cages.

Introduction

Ball Bearings

Cylindrical Roller Bearings

Spherical Roller Bearings

Tapered Roller Bearings

Thrust Bearings

Split Pillow Blocks

Super Precision Bearings

Linear Motion

Rolling Mill Bearings

Engineering Section

Bearing Selection

The original equipment manufacturer (OEM) will select a bearing for their equipment based on the loading requirements of, and the space available for, the bearing. The bearing style and size provide the foundation for the bearing selection based on the load carrying capacity in relation to the loads to be carried.

Selection Based on Basic Load Rating

The most common way to determine bearing life is by using the load ratings of the bearing and the loads required by the application. The common measurement is “**L₁₀**” life, defined as the number of revolutions before metal fatigue first appears on 10% of a large group of like bearings. This is referred to as basic rating life or fatigue life. The equations for calculating **L₁₀** life are:

$$\text{For ball bearings: } L_{10} = \left(\frac{C}{P}\right)^3 \quad \text{For roller bearings: } L_{10} = \left(\frac{C}{P}\right)^{10/3}$$

Where **L₁₀**: Rating fatigue life (1 million Revs)

P: Bearing Equivalent Load (lbf, N, kgf), see below for calculation of **P**

C: Basic Load Rating (from catalog tables)

For radial bearings, **C=Cr** For thrust bearings, **C=Ca**

If the bearings run at a constant speed, it is convenient to determine **L₁₀** life in terms of hours. This equation is expressed as

$$\text{For ball bearings: } L_{10h} = \frac{1,000,000}{60n} \left(\frac{C}{P}\right)^3 \quad \text{For roller bearings: } L_{10h} = \frac{1,000,000}{60n} \left(\frac{C}{P}\right)^{10/3}$$

Where **L_{10h}**: Rating fatigue life in hours **n**: Rotational speed, RPM

Equivalent Bearing Loads (P)

To determine the value of **P**, you must first determine the effects of the radial and axial loads applied. Once this hypothetical load is determined, it is assumed to be constant in magnitude and direction. The general formula for the calculation of **P** is: $P = X Fr + Y Fa$

Where **P**: Bearing equivalent load (lbf, N, kgf)

X: the Radial factor

Fr: the Actual constant radial load

Y: the Axial factor

Fa: the Actual constant axial load

The values for **X** and **Y** can be determined using the tables 10.2-10.4. First, determine the type of bearing being considered. Then, calculate the ratio of the axial load to the radial load and compare this to the bearings “**e**” value in the table.* The “**e**” value is determined by multiplying the axial load applied to the bearing by the bearing coefficient factor, **f₀**, which is obtained from the bearing tables. Divide the result by the static radial load rating. Locate the result in the first column and read across to find the “**e**” value. (In the case of angular contact bearings, the “**i**” value must be used. If a duplex pair in a DB or DF configuration is used, the “**i**” value is 2.) In effect, if the axial load is small compared to the radial load, then only the radial load is considered. If not, then a combination of the two is used. After determining the equivalent bearing load, **P**, the **L₁₀** formula given above can be used to determine the **L₁₀** life with 90% reliability for a given bearing’s basic load rating. Also, for a required **L₁₀** life, a basic load rating requirement can be found for bearing selection.

Table 10.2 — Equivalent Load Factors for Ball Bearings

Dynamic Equivalent Load $P=XFr+YFa$					
$\frac{f_o F_a}{C_{or}}$	e	$\frac{F_a}{F_r} \leq e$		$\frac{F_a}{F_r} > e$	
		X	Y	X	Y
0.172	0.19	1	0	0.56	2.30
0.345	0.22	1	0	0.56	1.99
0.689	0.26	1	0	0.56	1.71
1.03	0.28	1	0	0.56	1.55
1.38	0.30	1	0	0.56	1.45
2.07	0.34	1	0	0.56	1.31
3.45	0.38	1	0	0.56	1.15
5.17	0.42	1	0	0.56	1.04
6.89	0.44	1	0	0.56	1.00

Static Equivalent Load

$$\frac{F_a}{F_r} > 0.8, P_o = 0.6F_r + 0.5F_a$$

$$\frac{F_a}{F_r} \leq 0.8, P_o = F_r$$

Table 10.3 — Equivalent Load Factors for Angular Contact Ball Bearings

Dynamic Equivalent Load $P=XFr+YFa$										
Contact Angle	$\frac{if_o F_a^*}{C_{or}}$	e	Single, DT				DB or DF			
			$F_d/F_r \leq e$		$F_d/F_r > e$		$F_d/F_r \leq e$		$F_d/F_r > e$	
			X	Y	X	Y	X	Y	X	Y
15°	0.178	0.38	1	0	0.44	1.47	1	1.65	0.72	2.39
	0.357	0.40	1	0	0.44	1.40	1	1.57	0.72	2.28
	0.714	0.43	1	0	0.44	1.30	1	1.46	0.72	2.11
	1.07	0.46	1	0	0.44	1.23	1	1.38	0.72	2.00
	1.43	0.47	1	0	0.44	1.19	1	1.34	0.72	1.93
	2.14	0.50	1	0	0.44	1.12	1	1.26	0.72	1.82
	3.57	0.55	1	0	0.44	1.02	1	1.14	0.72	1.66
	5.35	0.56	1	0	0.44	1.00	1	1.12	0.72	1.63
25°	--	0.68	1	0	0.41	0.87	1	0.92	0.67	1.41
30°	--	0.80	1	0	0.39	0.76	1	0.78	0.63	1.24
40°	--	1.14	1	0	0.35	0.57	1	0.55	0.57	0.93

*For i , use 2 for DB, DF and 1 for DT.

Static Equivalent Load $P_o = X_o F_r + Y_o F_a$

Contact Angle	Single, DT		DB or DF	
	X_o	Y_o	X_o	Y_o
15°	0.5	0.46	1	0.92
25°	0.5	0.38	1	0.76
30°	0.5	0.33	1	0.66
40°	0.5	0.26	1	0.52

Single or DT mounting
When $F_r > 0.5F_r + Y_o F_a$
use $P_o = F_r$

Table 10.4 — Load Conversion Factors for Other Bearings

CYLINDRICAL ROLLER SPHERICAL ROLLER TAPERED ROLLER SELF-ALIGNING BALL	PLEASE CONSULT NSK ENGINEERING FOR VALUES, OR REFER TO NSK CATALOG E1101a
--	---

Correction of Basic Load Rating Due to Temperature

The operating temperature will significantly affect the fatigue life by altering the hardness of the bearing. Consequently, the basic load rating, which depends on the physical properties of the bearing material, will decrease with higher temperatures. Thus, the basic load rating must be corrected for higher temperatures using the equation: $C_t = f_t \cdot C$

Where C_t : Basic load rating after temperature correction

f_t : Temperature factor (see following table)

C : Basic load rating from tables, before application of temperature correction.

Table 10.5 — Temperature Factor (f_t)

	Bearing Temperature (°C)			
	≤150	175°	200°	250°
Temperature Factor f_t	1.00	.95	.90	.75

Adjustments to Fatigue Life Rating

Each style of bearing has many characteristics that make that bearing better suited for an application than another bearing. For example, some common applications require a bearing that can handle misalignment, loads in both directions, high speeds, etc..., or a combination of two or more. These operating conditions will alter the bearing life and are accounted for by using correction factors for temperature, reliability, bearing material, and other operating conditions. For the complete list of adjustment factors and their values, please contact NSK engineering or refer to NSK catalog E1101a.

The formula for adjusting life based on reliability, material, and operating conditions is:

$$L_{na} = a_1 * a_2 * a_3 * L_{10}$$

Where L_{na} : Adjusted life rating.

L_{10} : Life rating, adjusted for fatigue life for 90% reliability. This may not satisfy all applications. For higher reliability requirements, L_{10} must be adjusted.

a_1 : Life correction factor for reliability. This is determined from the reliability required of the bearing for its application (see table below).

a_2 : Life correction factor for bearing material.

a_3 : Life correction factor for operating conditions

Values of a_2 and a_3 are difficult to determine, however, for most applications, $a_2 * a_3 = 1$ can be assumed. If you have concerns about lubrication viscosity, temperature, contamination, misalignment, or other operating abnormalities, please consult NSK Engineering.

Table 10.6 — Reliability Factor (a_1).

	Reliability					
	90%	95%	96%	97%	98%	99%
a_1	1.00	.62	.53	.44	.33	.21

Static Load Rating

Some applications are stationary with loads for long periods, rotate at very low speeds, are subjected to slow oscillations, or are exposed to shock loads. In these events, the static load rating (C_{0r} or C_{0a}) must be used in the life calculations. Please contact NSK engineering for more details.

Selection Based on Dimensions

For single row bearings having the same width series, diameter series, and bore size, all styles have the same bore, O.D., and width. For example, 6203, NJ203, and 7203 all have a 17mm bore, a 42mm O.D., and 12mm width. Therefore, selection can be made based on the requirements of the application such as, speeds, misalignment capabilities, bearing value, etc..., provided that the life requirement is met by the bearing style.

Bearing Identification

Bearing Number Formulation

Bearings are identified by numbers and letters which designate bearing type, boundary dimensions, tolerance class, internal clearance and other specifications. The numbers used for standard bearings conform to ISO 15, Designation of Rolling Bearings.

Boundary dimensions for the most commonly used bearings are based on the ISO Boundary Dimensions Tables.

In order to establish certain standards in addition to those specified in ISO, NSK also uses various symbols of its own.

Table 10.7 — Bearing Series Numbers	Bearing Series	Bearing Type	Dimension Series	
			Width [†] Series	Diameter Series
Single Row Deep Groove Ball Bearing	68	6	(1)	8
	69	6	(1)	9
	60	6	(1)	0
	62	6	(0)	2
	63	6	(0)	3
	64	6	(0)	4
Single Row Angular Contact Ball Bearing	70	7	(1)	0
	72	7	(0)	2
	73	7	(0)	3
	74	7	(0)	4
Self-Aligning Ball Bearing	12	1	(0)	2
	13	1	(0)	3
	22	2	(2)	2
	23	2	(2)	3
Single Row Cylindrical Roller Bearing	NU10	NU	1	0
	NU2	NU	(0)	2
	NU22	NU	2	2
	NU3	NU	(0)	3
	NU23	NU	2	3
	NU4	NU	(0)	4
	NJ2	NJ	(0)	2
	NJ22	NJ	2	2
	NJ3	NJ	(0)	3
	NJ23	NJ	2	3
	NJ4	NJ	(0)	4
	N2	N	(0)	2
	N3	N	(0)	3
	N4	N	(0)	4
NF2	NF	(0)	2	
NF3	NF	(0)	3	
NF4	NF	(0)	4	
Double Row Cylindrical Roller Bearing	NNU49	NNU	4	9
	NN30	NN	2	0
Metric Tapered Roller Bearing	320	3	2	0
	302	3	0	2
	322	3	2	2
	303	3	0	3
	323	3	2	3
Spherical Roller Bearing	230	2	3	0
	231	2	3	1
	222	2	2	2
	232	2	3	2
	213 ^{††}	2	0	3
	223	2	2	3
Thrust Ball Bearing with Flat Seat	511	5	1	1
	512	5	1	2
	513	5	1	3
	514	5	1	4
	522	5	2	2
	523	5	2	3
	524	5	2	4
Spherical Roller Thrust Bearing	292	2	9	2
	293	2	9	3
	294	2	9	4

[†] The width series numbers shown in parentheses are usually omitted.

^{††} 213 is customary usage since this series would be 203 according to standard practice

Introduction

Ball Bearings

Cylindrical Roller Bearings

Spherical Roller Bearings

Tapered Roller Bearings

Thrust Bearings

Split Pillow Blocks

Super Precision Bearings

Linear Motion

Rolling Mill Bearings

Engineering Section

Bearing Number Formulation (Continued)

Bearing series numbers indicate bearing types and dimension series. They constitute the basic number structure for bearing designations. These are shown in Table 10.7 on page 306. Supplementary symbols and meanings of typical numbers and symbols are shown in Table 10.8 on page 308.

Typical examples of bearing designations are illustrated below:

6 3 08 ZZ C3
 | | | |
 | | | | Radial clearance (C3)
 | | | | Shields on Both Sides
 | | | | Bearing Bore (40mm)
 | | | | Diameter Series 3
 Single Row Deep Groove Ball Bearing

7 2 20 A DB C3
 | | | | | |
 | | | | | | Axial Clearance (C3)
 | | | | | | Back-to-Back Arrangement
 | | | | | | Contact Angle (30°)
 | | | | | | Bearing Bore (100mm)
 | | | | | | Diameter Series 2
 Single Row Angular Contact Ball Bearing

1 2 06 K + H206
 | | | | |
 | | | | | Adapter with 25mm Bore
 | | | | | Tapered Bore (1:12 Taper)
 | | | | | Bearing Bore (30mm)
 | | | | | Diameter Series 2
 Self-Aligning Ball Bearing

HR 3 0 2 07 J
 | | | | | |
 | | | | | | Small Diameter of Outer Ring Raceway
 | | | | | | and Contact Angle Conform to ISO
 | | | | | | Standard
 | | | | | | Bearing Bore (35mm)
 | | | | | | Diameter Series 2
 | | | | | | Width Series 0
 Tapered Roller Bearing
 High Capacity Bearing

NU 3 18 M ()
 | | | | |
 | | | | | Radial Clearance (Blank is CN)
 | | | | | Machined Brass Cage
 | | | | | Bearing Bore (90mm)
 | | | | | Diameter Series 3
 Cylindrical Roller Bearing (NU Type)

2 4 0 /1000 M K30 E4 C3
 | | | | | | | |
 | | | | | | | | Radial Clearance (C3)
 | | | | | | | | Outer Ring with Oil Groove
 | | | | | | | | and Oil Holes
 | | | | | | | | Tapered Bore (1:30 Taper)
 | | | | | | | | Machined Brass Cage
 | | | | | | | | Bearing Bore (1,000mm)
 | | | | | | | | Diameter Series 0
 | | | | | | | | Width Series 4
 Spherical Roller Bearing

NN 3 0 17 K CC1 P4
 | | | | | | |
 | | | | | | | Tolerance to ISO Class 4
 | | | | | | | Radial Clearance for Matched
 | | | | | | | Cylindrical Roller Bearings
 | | | | | | | Tapered Bore (1:12 Taper)
 | | | | | | | Bearing Bore (85mm)
 | | | | | | | Diameter Series 0
 | | | | | | | Width Series 3
 Cylindrical Roller Bearing (NN Type)

5 1 2 15
 | | | |
 | | | | Bearing Bore (75mm)
 | | | | Diameter Series 2
 | | | | Height Series 1
 Thrust Ball Bearing

Table 10.8 — Formulation of Bearing Numbers

Introduction	Basic Bearing		Bore		Bearing Series								
	Bearing Series	Bore	1 thru 9	Bore in mm									
Ball Bearings	Basic Bearing	Contact Angle	00	10mm	68								
			01	12mm	69								
02			15mm	60									
03			17mm	:									
/22			22mm	70									
/28			28mm	72									
Cylindrical Roller Bearings	Internal Design	Material	/32	32mm	73								
			04 thru 96	Multiply by 5 for Bore in mm (ex. 04=20mm)	:								
/500 thru /2500			Bore in mm	12									
Spherical Roller Bearings			External Seals, Shields	Z	CA	Spherical Roller Bearings with Machined Cages	13						
							22						
Tapered Roller Bearings							ZZ	DU	CD	Spherical Roller Bearings with Pressed Cages	NJ 2		
	N 3												
Thrust Bearings	DU	DDU									E	Cylindrical Roller Bearings	NN
													30
Split Pillow Blocks			V	VV	H	Spherical Radial and Thrust Roller Bearings							:
													320
Super Precision Bearings							Non-Contact Rubber Seal on One Side Only	V	HR	Tapered Roller Bearings			322
													323
Linear Motion Bearings	V	VV									g	Case-Hardened Steel Used in Outer Rings, Inner Rings and Rolling Elements	:
													230
Rolling Mill Bearings			V	VV	h	Stainless Steel Used in Outer Rings, Inner Rings and Rolling Elements							222
													223
Engineering Section							V	VV	M	Machined Brass Cages			:
													511
	V	VV									W	Pressed Steel Cages	512
													513
			V	VV	T	Phenolic Resin/Polyamide Cages							:
													292
							V	VV	V	Bearings without Cages (Cageless Ball and Roller Bearings)			293
													294
	V	VV									H	(Spherical Bearings) Polyamide Cages	:
													299
			V	VV	H	(Spherical Bearings) Polyamide Cages							300
													301

Table 10.8 — Formulation of Bearing Numbers (continued) – Supplementary Symbols

Supplementary Features	Features			Features Design of Outer and Inner Ring			
	Arrangement						
	Radial Internal Clearance						
	Tolerance Class	Tolerance Class					
	Special Specifications						
	Spacer or Sleeve						
		(None)	ISO Class 0 (ABEC 1)	K	Tapered Bore (Taper 1:12)		
		P6	ISO Class 6 (ABEC 3)	K30	Tapered Bore (Taper 1:30)		
		P5	ISO Class 5 (ABEC 5)	E4	Lubrication Grooves and Holes in Outer Ring		
		P4	ISO Class 4 (ABEC 7)	N	Snap Ring Groove in Outer Ring		
				NR	Snap Ring Groove with Snap Ring in Outer Ring		
		Special Specifications		Arrangement			
		X28	Inner and Outer Rings Heat Stabilized for Maximum Working Temperature of 200°C	DB	Back to Back Duplex Arrangement		
		S11	Spherical Bearings Heat Stabilized to 200°C	DF	Face to Face Duplex Arrangement		
		P55	High Running Accuracy of Inner and Outer Rings	DT	Tandem Duplex Arrangement		
				SU	Single Universal – Bearings with front and back face stand-out adjusted to be equal		
				DU	Duplex Universal (SU sold as pair)		
		Spacer or Sleeve		Radial Internal Clearance			
	+K	Bearings with Outer Ring Spacer		C2	For All Radial Ball Bearings	Clearance Less Than Normal	
	+L	Bearings with Inner Ring Spacer		C0			Normal Clearance
	+KL	Bearings with Both Outer and Inner Ring Spacers		C3			Clearance Greater Than Normal
	+H	Adapter Designation		C4			Clearance Greater Than C3
	+AH	Withdrawal Sleeve Designation		CC1	For Matched Cylindrical Roller Bearings	Clearance Less Than C	
	HJ	Angle Ring Designation		CC2		Clearance Less Than Normal	
				CC		Normal Clearance	
				CC3		Clearance Greater Than Normal	
				CC4		Clearance Greater Than CC3	
				CC5	Clearance Greater Than CC4		
				MC2	For Extra Small Ball Bearings and Miniature Bearings	Clearance Less Than MC3	
				MC3		Normal Clearance	
				MC4		Clearance Greater Than MC3	
				MC5		Clearance Greater Than MC4	
	Lubrication						
	AKC	Exxon Andok C					
	AV2	Shell Alvania No. 2					
	B32	Exxon Beacon 325					
	SRI	Chevron SRI-2					
	SDR	Shell Dolium R					

Introduction

Ball Bearings

Cylindrical Roller Bearings

Spherical Roller Bearings

Tapered Roller Bearings

Thrust Bearings

Split Pillow Blocks

Super Precision Bearings

Linear Motion

Rolling Mill Bearings

Engineering Section

Snap Ring and Groove Dimensions

Table 10.9 — Snap Ring and Groove Dimensions (Dimension Series 0,2,3 & 4)

Units: inch

BEARING BORE d (mm)				SNAP RING GROOVE POSITION, a		GROOVE WIDTH, b	SNAP RING THICKNESS, f	SNAP RING O.D., D ₂	HOUSING BORE, D _x
DIMENSION SERIES									
0	2	3	4	0	2,3,4	med.	med.	max.	min.
10	—	—	—	0.0500	—	0.0402	0.0311	1.1299	1.1575
12	—	—	—	0.0500	—	0.0402	0.0311	1.2087	1.2362
—	10	9	8	—	0.0780	0.0591	0.0421	1.3661	1.3976
15	12	—	9	0.0780	0.0780	0.0591	0.0421	1.4449	1.4764
17	15	10	—	0.0780	0.0780	0.0591	0.0421	1.5630	1.5945
—	—	12	10	—	0.0780	0.0591	0.0421	1.6260	1.6535
—	17	—	—	—	0.0780	0.0591	0.0421	1.7559	1.7913
20	—	15	12	0.0780	0.0780	0.0591	0.0421	1.8228	1.8504
22	—	—	—	0.0780	—	0.0591	0.0421	1.9016	1.9291
25	20	17	—	0.0780	0.0939	0.0591	0.0421	2.0748	2.1063
—	22	—	—	—	0.0939	0.0591	0.0421	2.1929	2.2244
28	25	20	15	0.0780	0.0939	0.0591	0.0421	2.2795	2.3031
30	—	—	—	0.0780	—	0.0591	0.0421	2.3898	2.4213
—	—	22	—	—	0.0939	0.0591	0.0421	2.4291	2.4606
32	28	—	—	0.0780	0.0939	0.0591	0.0421	2.5079	2.5394
35	30	25	17	0.0780	0.1250	0.0807	0.0650	2.6654	2.6969
—	32	—	—	—	0.1250	0.0807	0.0650	2.7835	2.8150
40	—	28	—	0.0941	0.1250	0.0807	0.0650	2.9370	2.9921
—	35	30	20	—	0.1250	0.0807	0.0650	3.0945	3.1496
45	—	32	—	0.0941	0.1250	0.0807	0.0650	3.2126	3.2677
50	40	35	25	0.0941	0.1250	0.0807	0.0650	3.4094	3.4646
—	45	—	—	—	0.1250	0.0807	0.0650	3.6063	3.6614
55	50	40	30	0.1130	0.1250	0.1122	0.0949	3.7992	3.8583
60	—	—	—	0.1130	—	0.1122	0.0949	4.0000	4.0551
65	55	45	35	0.1130	0.1250	0.1122	0.0949	4.1929	4.2520
70	60	50	40	0.1130	0.1250	0.1122	0.0949	4.5906	4.6457
75	—	—	—	0.1130	—	0.1122	0.0949	4.7874	4.8425
—	65	55	45	—	0.1559	0.1280	0.1091	5.1063	5.1772
80	70	—	—	0.1130	0.1559	0.1280	0.1091	5.3031	5.3740
85	75	60	50	0.1130	0.1559	0.1280	0.1091	5.5000	5.5709
90	80	65	55	0.1409	0.1880	0.1280	0.1091	5.8937	5.9843
95	—	—	—	0.1409	—	0.1280	0.1091	6.0906	6.1811
100	85	70	60	0.1409	0.1880	0.1280	0.1091	6.2874	6.3780
105	90	75	65	0.1409	0.1880	0.1280	0.1091	6.6811	6.7717
110	95	80	—	0.1409	0.2191	0.1437	0.1437	7.2008	7.2835
120	100	85	70	0.1409	0.2191	0.1437	0.1437	7.5945	7.6772
—	105	90	75	—	0.2191	0.1437	0.1437	7.9882	8.0709
130	110	95	80	0.2191	0.2191	0.1437	0.1437	8.3819	8.4646

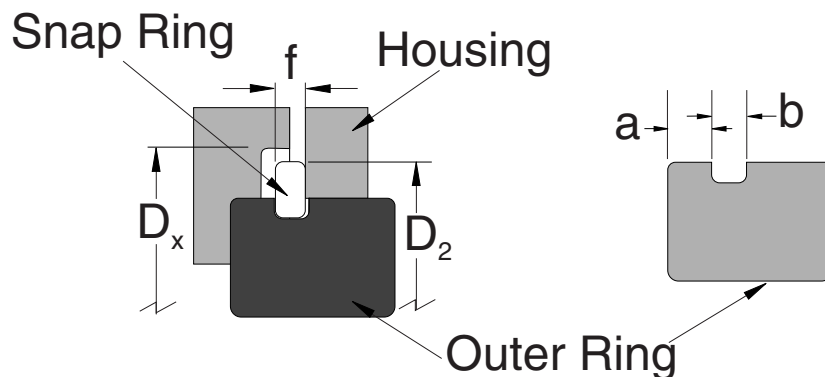
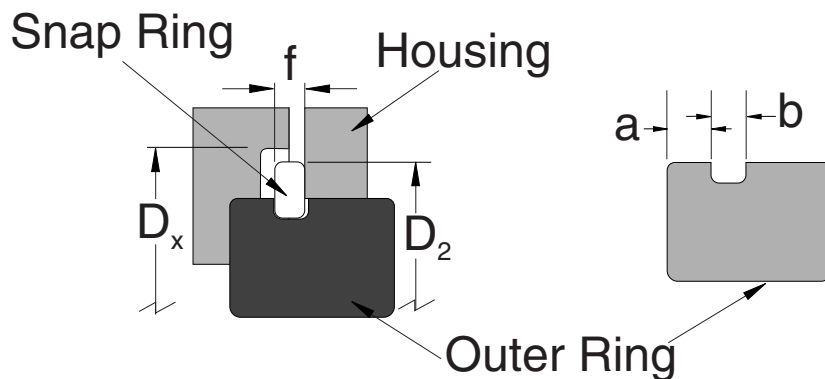

Table 10.10 — Snap Ring and Groove Dimensions (Series 6800 & 6900)

Units: inch

BEARING BORE d (mm)		SNAP RING GROOVE POSITION, a		GROOVE WIDTH, b	SNAP RING THICKNESS, f	SNAP RING O.D., D ₂	HOUSING BORE, D _x
DIMENSION SERIES							
8	9	8	9	med.	med.	max.	min.
—	10	—	1.0677	0.0222	0.0256	0.9764	1.0039
—	12	—	1.0677	0.0222	0.0256	1.0551	1.0827
—	15	—	1.3226	0.0423	0.0315	1.2126	1.2402
—	17	—	1.3226	0.0423	0.0315	1.2913	1.3189
20	—	0.0482	—	0.0423	0.0315	1.3701	1.3976
22	—	0.0482	—	0.0423	0.0315	1.4488	1.4764
25	20	0.0482	1.7305	0.0423	0.0315	1.5669	1.5945
—	22	—	1.7305	0.0423	0.0315	1.6457	1.6732
28	—	0.0482	—	0.0423	0.0315	1.6850	1.7126
30	25	0.0482	1.7305	0.0423	0.0315	1.7638	1.7913
32	—	0.0482	—	0.0423	0.0315	1.8425	1.8701
—	28	—	1.7305	0.0423	0.0315	1.8819	1.9094
35	30	0.0482	1.7305	0.0423	0.0315	1.9606	1.9882
40	32	0.0482	1.7305	0.0423	0.0315	2.1575	2.1850
—	35	—	1.7305	0.0423	0.0315	2.2756	2.3031
45	—	0.0482	—	0.0423	0.0315	2.3937	2.4213
—	40	—	1.7305	0.0423	0.0315	2.5512	2.5787
50	—	0.0482	—	0.0423	0.0315	2.6693	2.6969
—	45	—	1.7305	0.0571	0.0421	2.7874	2.8346
55	50	0.0640	1.7305	0.0571	0.0421	2.9449	2.9921
60	—	0.0640	—	0.0571	0.0421	3.2559	3.3071
—	55	—	2.1374	0.0571	0.0421	3.3228	3.3858
65	60	0.0640	2.1374	0.0571	0.0421	3.5197	3.5827
70	65	0.0640	2.1374	0.0571	0.0421	3.7165	3.7795
75	—	0.0640	—	0.0571	0.0421	3.9134	3.9764
80	70	0.0640	2.5453	0.0571	0.0421	4.1102	4.1732
—	75	—	2.5453	0.0571	0.0421	4.3583	4.4094
85	80	0.0787	2.5453	0.0571	0.0421	4.5551	4.6063
90	—	0.0787	—	0.0571	0.0421	4.7520	4.8031
95	85	0.0787	3.3610	0.0571	0.0421	4.9488	5.0000
100	90	0.0787	3.3610	0.0571	0.0421	5.1457	5.1969
105	95	0.0787	3.3610	0.0571	0.0421	5.3425	5.3937
110	100	0.0945	3.3610	0.0807	0.0650	5.7362	5.7874
—	105	—	3.3610	0.0807	0.0650	5.9331	5.9843
120	110	0.0945	3.3610	0.0807	0.0650	6.1299	6.1811
130	120	0.1260	3.3610	0.0807	0.0650	6.7520	6.8110
140	—	0.1260	—	0.0807	0.0650	7.1457	7.2047
—	130	—	3.3610	0.0807	0.0650	7.3425	7.4016
150	140	0.1260	3.3610	0.0807	0.0650	7.7362	7.7953
160	—	0.1260	—	0.0807	0.0650	8.1299	8.1890



Introduction

Ball Bearings

Cylindrical Roller Bearings

Spherical Roller Bearings

Tapered Roller Bearings

Thrust Bearings

Split Pillow Blocks

Super Precision Bearings

Linear Motion

Rolling Mill Bearings

Engineering Section

Bearing Tolerances

BEARING TOLERANCE STANDARDS

The dimensional and running accuracies of rolling bearings are standardized by ISO with regard to the following items:

- Tolerances for bore diameter, outer diameter, individual ring width, and overall width.
- Tolerances for absolute dimensions of inscribed circle diameter and circumscribed circle diameter.
- Tolerances for chamfer dimension.
- Tolerances for width variations
- Tolerances for taper angle and taper bore diameters
- Tolerances for radial runout of inner ring and outer rings.
- Tolerances for axial runout of inner and outer rings.
- Tolerances for side or face runout of inner ring.
- Tolerances for side or face runout of outer ring.

In grading bearing tolerances, ISO “normal class” represents the standard. ISO classes 6, 5, 4, and 2 represent four higher grades. In general, DIN, JIS, and ABMA tolerance classes conform to these ISO standards. Tolerance classes applicable to each bearing type are shown in the subsequent tables.

Table 10.11 — Bearing Types and Tolerance Classes

Bearing Types		Applicable Tolerance Classes					Applicable Tables	Applicable Pages	
Angular Contact Ball Bearings		Class N	Class 6	Class 5	Class 4	Class 2	9-12 to 9-16	236 to 239	
Self-Aligning Ball Bearings		Class N	Class 6 equivalent	Class 5 equivalent	–	–			
Cylindrical Roller Bearings		Class N	Class 6	Class 5	Class 4	Class 2			
Spherical Roller Bearings		Class N	Class 6 equivalent	Class 5 equivalent	–	–			
Tapered Roller Bearings	Metric Design	Class N Class 6X	–	Class 5	Class 4	–	9-17 to 9-21	240 to 242	
	Inch Design	ABMA Class 4	ABMA Class 2	ABMA Class 3	ABMA Class 0	ABMA Class 00	9-22 to 9-24	244 to 244	
Thrust Ball Bearings		Class N	Class 6	Class 5	Class 4	–	9-25 to 9-27	246 to 247	
Spherical Roller Thrust Bearings		Class N	–	–	–	–	9-28 to 9-29	248 to 248	
Equivalent Standards (ref.)	JIS ¹		Class 0	Class 6	Class 5	Class 4	Class 2	–	–
	DIN ²		0	P6	P5	P4	P2	–	–
	ABMA ³	Ball Bearings	ABEC 1	ABEC 3	ABEC 5 (Class 5P)	ABEC 7 (Class 7P)	ABEC 9 (Class 9P)	9-12 to 9-16	236 to 239
		Roller Bearings	RBEC 1	RBEC 3	RBEC 5			–	–
	Tapered Roller Bearings	Class 4	Class 2	Class 3	Class 0	Class 00	9-22 to 9-24	244 to 244	

1) JIS: Japanese Industrial Standards, 2) DIN: Deutch Industrie Norm, 3) ABMA: American Bearing Manufacturers Association

Bearing Tolerance Nomenclature

Rough definitions of the items listed above for running accuracy and their measuring methods are shown below. They are described in detail in ISO 5593 (Rolling Bearings-Vocabulary), JIS B 1515 (Measuring Methods for Rolling Bearings), and elsewhere.

Symbols for Boundary Dimensions and Running Accuracy

d Bearing bore diameter, nominal	Δ_{Ts} Deviation of the actual bearing width
Δ_{ds} Deviation of single bore diameter	D Bearing outside diameter, nominal
Δ_{dmp} Single plane mean bore diameter deviation	Δ_{Ds} Deviation of a single outside diameter
V_{dp} Bore diameter variation in a single radial plane	Δ_{Dmp} Single plane mean outside diameter deviation
V_{dmp} Mean bore diameter variation	V_{Dp} Outside diameter variation in a single radial plane
B Inner ring width, nominal	V_{Dmp} Mean outside diameter variation
Δ_{Bs} Deviation of a single inner ring width	C Outer ring width, nominal
V_{Bs} Inner ring width variation	Δ_{Cs} Deviation of a single outer ring width
K_{ia} Radial runout of assembled bearing inner ring	V_{Cs} Outer ring width variation
S_d Inner ring reference face (backface, where applicable) runout with bore	K_{ea} Radial runout of assembled bearing outer ring
S_{ia} Assembled bearing inner ring face (backface) runout with raceway	S_D Variation of bearing outside surface generatrix inclination with outer ring reference face (backface)
S_i, S_e Raceway to backface thickness variation of thrust bearing	S_{ea} Assembled bearing outer ring (backface) runout with raceway
T Bearing width, nominal	

Measuring Methods for Running Accuracy (summarized)

Illustrations	Running Accuracy	Inner Ring	Outer Ring	Dial Gage
	K_{ia}	Rotating	Stationary	A
	K_{ea}	Stationary	Rotating	A
	S_{ia}	Rotating	Stationary	B1
	S_{ea}	Stationary	Rotating	B2
	S_d	Rotating	Stationary	C
	S_D	-	Rotating	D
	S_i, S_e	Only the shaft or housing or central washer is to be rotated.		E

Table 10.12 — Tolerances for Inner Ring Bore of Radial Bearings (excluding Tapered Roller Bearings)



Units: inch

Nominal Bore Diameter <i>d</i> (mm)		$\Delta dmp(1)$										<i>ds</i> (1)			
		Class N		Class 6		Class 5		Class 4		Class 2		Class 4 Diameter Series 0, 1, 2, 3, 4		Class 2	
over	incl	high	low	high	low	high	low	high	low	high	low	high	low	high	low
0.6 ²⁾	2.5	0	-0.003	0	-0.003	0	-0.002	0	-0.002	0	-0.001	0	-0.002	0	-0.001
2.5	10	0	-0.003	0	-0.003	0	-0.002	0	-0.002	0	-0.001	0	-0.002	0	-0.001
10	18	0	-0.003	0	-0.003	0	-0.002	0	-0.002	0	-0.001	0	-0.002	0	-0.001
18	30	0	-0.004	0	-0.003	0	-0.002	0	-0.002	0	-0.001	0	-0.002	0	-0.001
30	50	0	-0.005	0	-0.004	0	-0.003	0	-0.002	0	-0.001	0	-0.002	0	-0.001
50	80	0	-0.006	0	-0.005	0	-0.004	0	-0.003	0	-0.002	0	-0.003	0	-0.002
80	120	0	-0.008	0	-0.006	0	-0.004	0	-0.003	0	-0.002	0	-0.003	0	-0.002
120	150	0	-0.010	0	-0.007	0	-0.005	0	-0.004	0	-0.003	0	-0.004	0	-0.003
150	180	0	-0.010	0	-0.007	0	-0.005	0	-0.004	0	-0.003	0	-0.004	0	-0.003
180	250	0	-0.012	0	-0.009	0	-0.006	0	-0.005	0	-0.003	0	-0.005	0	-0.003
250	315	0	-0.014	0	-0.010	0	-0.007	-	-	-	-	-	-	-	-
315	400	0	-0.016	0	-0.012	0	-0.009	-	-	-	-	-	-	-	-
400	500	0	-0.018	0	-0.014	-	-	-	-	-	-	-	-	-	-
500	630	0	-0.020	0	-0.016	-	-	-	-	-	-	-	-	-	-
630	800	0	-0.030	-	-	-	-	-	-	-	-	-	-	-	-
800	1000	0	-0.039	-	-	-	-	-	-	-	-	-	-	-	-
1000	1250	0	-0.049	-	-	-	-	-	-	-	-	-	-	-	-
1250	1600	0	-0.063	-	-	-	-	-	-	-	-	-	-	-	-
1600	2000	0	-0.079	-	-	-	-	-	-	-	-	-	-	-	-

Note: 1) Applicable to bearings with cylindrical bores.
2) 0.6 mm is included in this group.

Table 10.13 — Tolerances for Outer Ring O.D. of Radial Bearings (excluding Tapered Roller Bearings)



Units: inch

Nominal Outside Diameter <i>D</i> (mm)		ΔDmp										ΔDs			
		Class N		Class 6		Class 5		Class 4		Class 2		Class 4 Diameter Series 0, 1, 2, 3, 4		Class 2	
		over	incl	high	low	high	low	high	low	high	low	high	low	high	low
2.5 ¹⁾	6	0	-0.003	0	-0.003	0	-0.002	0	-0.002	0	-0.001	0	-0.002	0	-0.001
6	18	0	-0.003	0	-0.003	0	-0.002	0	-0.002	0	-0.001	0	-0.002	0	-0.001
18	30	0	-0.004	0	-0.003	0	-0.002	0	-0.002	0	-0.002	0	-0.002	0	-0.002
30	50	0	-0.004	0	-0.004	0	-0.003	0	-0.002	0	-0.002	0	-0.002	0	-0.002
50	80	0	-0.005	0	-0.004	0	-0.004	0	-0.003	0	-0.002	0	-0.003	0	-0.002
80	120	0	-0.006	0	-0.005	0	-0.004	0	-0.003	0	-0.002	0	-0.003	0	-0.002
120	150	0	-0.007	0	-0.006	0	-0.004	0	-0.004	0	-0.002	0	-0.004	0	-0.002
150	180	0	-0.010	0	-0.007	0	-0.005	0	-0.004	0	-0.003	0	-0.004	0	-0.003
180	250	0	-0.012	0	-0.008	0	-0.006	0	-0.004	0	-0.003	0	-0.004	0	-0.003
250	315	0	-0.014	0	-0.010	0	-0.007	0	-0.005	0	-0.003	0	-0.005	0	-0.003
315	400	0	-0.016	0	-0.011	0	-0.008	0	-0.006	0	-0.004	0	-0.006	0	-0.004
400	500	0	-0.018	0	-0.013	0	-0.009	-	-	-	-	-	-	-	-
500	630	0	-0.020	0	-0.015	0	-0.011	-	-	-	-	-	-	-	-
630	800	0	-0.030	0	-0.018	0	-0.014	-	-	-	-	-	-	-	-
800	1000	0	-0.039	0	-0.024	-	-	-	-	-	-	-	-	-	-
1000	1250	0	-0.049	-	-	-	-	-	-	-	-	-	-	-	-
1250	1600	0	-0.063	-	-	-	-	-	-	-	-	-	-	-	-
1600	2000	0	-0.079	-	-	-	-	-	-	-	-	-	-	-	-
2000	2500	0	-0.098	-	-	-	-	-	-	-	-	-	-	-	-

Note: 1) 2.5 mm is included within this group.
Remarks: 1) The outside diameter low tolerances specified in this table do not apply within a distance of 1.2 times the chamfer dimension *r* (max) from the ring face.
2) The cylindrical bore diameter "no-go" side" tolerance limit (high) specified in this table does not necessarily apply within a distance of 1.2 times the chamfer dimension *r* (max) from the ring face.
3) ABMA Std 20-1987 was amended: ABEC1 ° RBEC1, ABEC3 ° RBEC3, ABEC5 ° RBEC5, ABEC7, and ABEC9 are equivalent to Classes N, 6,5,4, and 2 respectively.

Table 10.12 —Tolerances for Inner Ring Bore of Radial Bearings (excluding Tapered Roller Bearings) (continued)

Units: inch

$V_{dp}^{(1)}$										$V_{dmp}^{(1)}$					
Class N			Class 6			Class 5		Class 4		Class	Class				
Diameter Series			Diameter Series			Dia. Series		Dia. Series							
7,8,9	0,1	2,3,4	7,8,9	0,1	2,3,4	7,8,9	0,1,2,3,4	7,8,9	0,1,2,3,4	2	N	6	5	4	2
max	max	max	max	max	max	max	max	max	max	max	max	max	max	max	max
+0.004	+0.003	+0.002	+0.004	+0.003	+0.002	+0.002	+0.002	+0.002	+0.001	+0.001	+0.002	+0.002	+0.001	+0.001	+0.001
+0.004	+0.003	+0.002	+0.004	+0.003	+0.002	+0.002	+0.002	+0.002	+0.001	+0.001	+0.002	+0.002	+0.001	+0.001	+0.001
+0.004	+0.003	+0.002	+0.004	+0.003	+0.002	+0.002	+0.002	+0.002	+0.001	+0.001	+0.002	+0.002	+0.001	+0.001	+0.001
+0.005	+0.004	+0.003	+0.004	+0.003	+0.002	+0.002	+0.002	+0.002	+0.001	+0.001	+0.003	+0.002	+0.001	+0.001	+0.001
+0.006	+0.005	+0.004	+0.005	+0.004	+0.003	+0.003	+0.002	+0.002	+0.001	+0.001	+0.004	+0.003	+0.002	+0.001	+0.001
+0.007	+0.007	+0.004	+0.006	+0.006	+0.004	+0.004	+0.003	+0.003	+0.002	+0.002	+0.004	+0.004	+0.002	+0.001	+0.001
+0.010	+0.010	+0.006	+0.007	+0.007	+0.004	+0.004	+0.003	+0.003	+0.002	+0.002	+0.006	+0.004	+0.002	+0.002	+0.001
+0.012	+0.012	+0.007	+0.009	+0.009	+0.006	+0.005	+0.004	+0.004	+0.003	+0.003	+0.007	+0.006	+0.003	+0.002	+0.001
+0.012	+0.012	+0.007	+0.009	+0.009	+0.006	+0.005	+0.004	+0.004	+0.003	+0.003	+0.007	+0.006	+0.003	+0.002	+0.001
+0.015	+0.015	+0.009	+0.011	+0.011	+0.007	+0.006	+0.005	+0.005	+0.004	+0.003	+0.009	+0.007	+0.003	+0.002	+0.002
+0.017	+0.017	+0.010	+0.012	+0.012	+0.007	+0.007	+0.006	-	-	-	+0.010	+0.007	+0.004	-	-
+0.020	+0.020	+0.012	+0.015	+0.015	+0.009	+0.009	+0.007	-	-	-	+0.012	+0.009	+0.005	-	-
+0.022	+0.022	+0.013	+0.017	+0.017	+0.010	-	-	-	-	-	+0.013	+0.010	-	-	-
+0.025	+0.025	+0.015	+0.020	+0.020	+0.012	-	-	-	-	-	+0.015	+0.012	-	-	-
-	-	-	-	-	-	-	-	-	-	-	-	-	-	-	-
-	-	-	-	-	-	-	-	-	-	-	-	-	-	-	-
-	-	-	-	-	-	-	-	-	-	-	-	-	-	-	-
-	-	-	-	-	-	-	-	-	-	-	-	-	-	-	-

Note: 1) Applicable to bearings with cylindrical bores.

Table 10.13 —Tolerances for Outer Ring O.D. of Radial Bearings (excluding Tapered Roller Bearings) (continued)

Units: inch

$V_{Dp}^{(1)}$												$V_{Dmp}^{(1)}$					
Class N				Class 6				Class 5		Class 4		Class 2	Class				
Open Type		Shielded Sealed	Open Type		Shielded Sealed	Open Type		Open Type									
Diameter Series				Diameter Series				Dia. Series		Dia. Series		Open Type	Class				
7,8,9	0,1	2,3,4	2,3,4	7,8,9	0,1	2,3,4	0,1,2,3,4	7,8,9	0,1,2,3,4	7,8,9	0,1,2,3,4						
max	max	max	max	max	max	max	max	max	max	max	max	max	max	max	max	max	
+0.004	+0.003	+0.002	+0.004	+0.004	+0.003	+0.002	+0.004	+0.002	+0.002	+0.002	+0.001	+0.001	+0.002	+0.002	+0.001	+0.001	+0.001
+0.005	+0.004	+0.003	+0.005	+0.004	+0.003	+0.002	+0.004	+0.002	+0.002	+0.002	+0.002	+0.002	+0.003	+0.002	+0.001	+0.001	+0.001
+0.006	+0.004	+0.003	+0.006	+0.004	+0.004	+0.003	+0.005	+0.003	+0.002	+0.002	+0.002	+0.002	+0.003	+0.003	+0.002	+0.001	+0.001
+0.006	+0.005	+0.004	+0.008	+0.006	+0.004	+0.003	+0.006	+0.003	+0.003	+0.003	+0.002	+0.002	+0.004	+0.003	+0.002	+0.001	+0.001
+0.007	+0.007	+0.004	+0.010	+0.006	+0.006	+0.004	+0.008	+0.004	+0.003	+0.003	+0.002	+0.002	+0.004	+0.004	+0.002	+0.002	+0.001
+0.009	+0.009	+0.006	+0.012	+0.007	+0.007	+0.004	+0.010	+0.004	+0.003	+0.004	+0.003	+0.002	+0.006	+0.004	+0.002	+0.002	+0.001
+0.012	+0.012	+0.007	+0.015	+0.009	+0.009	+0.006	+0.012	+0.005	+0.004	+0.004	+0.003	+0.003	+0.007	+0.006	+0.003	+0.002	+0.001
+0.015	+0.015	+0.009	-	+0.010	+0.010	+0.006	-	+0.006	+0.004	+0.004	+0.003	+0.003	+0.009	+0.006	+0.003	+0.002	+0.002
+0.017	+0.017	+0.010	-	+0.012	+0.012	+0.007	-	+0.007	+0.006	+0.005	+0.004	+0.003	+0.010	+0.007	+0.004	+0.003	+0.002
+0.020	+0.020	+0.012	-	+0.014	+0.014	+0.008	-	+0.008	+0.006	+0.006	+0.004	+0.004	+0.012	+0.008	+0.004	+0.003	+0.002
+0.022	+0.022	+0.013	-	+0.016	+0.016	+0.010	-	+0.009	+0.007	-	-	-	+0.013	+0.010	+0.005	-	-
+0.025	+0.025	+0.015	-	+0.019	+0.019	+0.011	-	+0.011	+0.008	-	-	-	+0.015	+0.011	+0.006	-	-
+0.037	+0.037	+0.022	-	+0.022	+0.022	+0.013	-	+0.014	+0.010	-	-	-	+0.022	+0.013	+0.007	-	-
+0.049	+0.049	+0.030	-	+0.030	+0.030	+0.018	-	-	-	-	-	-	+0.030	+0.018	-	-	-
-	-	-	-	-	-	-	-	-	-	-	-	-	-	-	-	-	-
-	-	-	-	-	-	-	-	-	-	-	-	-	-	-	-	-	-
-	-	-	-	-	-	-	-	-	-	-	-	-	-	-	-	-	-
-	-	-	-	-	-	-	-	-	-	-	-	-	-	-	-	-	-

Note: 1) Applicable only when a locating snap ring is not used

Introduction

Ball Bearings

Cylindrical Roller Bearings

Spherical Roller Bearings

Tapered Roller Bearings

Thrust Bearings

Split Pillow Blocks

Super Precision Bearings

Linear Motion

Rolling Mill Bearings

Engineering Section

Table 10.14 — Tolerances for Inner and Outer Ring Widths of Radial Bearings (excluding Tapered Roller Bearings)

Units: inch

Nominal Bore Diameter <i>d</i> (mm)		ΔB_s (or C_s) ⁽¹⁾										V_{Bs} (or V_{Cs}) ⁽¹⁾				
		Single Bearing						Combined Bearings ⁽²⁾				Inner Ring (or Outer Ring) ⁽²⁾		Inner Ring		
		Class N Class 6		Class 5 Class 4		Class 2		Class N Class 6		Class 5 Class 4		Class		Class		
		high	low	high	low	high	low	high	low	high	low	N	6	5	4	2
over	incl	high	low	high	low	high	low	high	low	high	low	max	max	max	max	max
0.6 ³⁾	2.5	0	-0.016	0	-0.016	0	-0.016	—	—	0	-0.098	+0.005	+0.005	+0.002	+0.001	+0.001
2.5	10	0	-0.047	0	-0.047	0	-0.047	0	-0.098	0	-0.098	+0.006	+0.006	+0.002	+0.001	+0.001
10	18	0	-0.047	0	-0.047	0	-0.047	0	-0.098	0	-0.098	+0.008	+0.008	+0.002	+0.001	+0.001
18	30	0	-0.047	0	-0.047	0	-0.047	0	-0.098	0	-0.098	+0.008	+0.008	+0.002	+0.001	+0.001
30	50	0	-0.047	0	-0.047	0	-0.047	0	-0.098	0	-0.098	+0.008	+0.008	+0.002	+0.001	+0.001
50	80	0	-0.059	0	-0.059	0	-0.059	0	-0.150	0	-0.150	+0.010	+0.010	+0.002	+0.002	+0.001
80	120	0	-0.079	0	-0.079	0	-0.079	0	-0.150	0	-0.150	+0.010	+0.010	+0.003	+0.002	+0.001
120	150	0	-0.098	0	-0.098	0	-0.098	0	-0.197	0	-0.150	+0.012	+0.012	+0.003	+0.002	+0.001
150	180	0	-0.098	0	-0.098	0	-0.118	0	-0.197	0	-0.150	+0.012	+0.012	+0.003	+0.002	+0.002
180	250	0	-0.118	0	-0.118	0	-0.138	0	-0.197	0	-0.197	+0.012	+0.012	+0.004	+0.002	+0.002
250	315	0	-0.138	0	-0.138	—	—	0	-0.197	0	-0.197	+0.014	+0.014	+0.005	—	—
315	400	0	-0.157	0	-0.157	—	—	0	-0.248	0	-0.248	+0.016	+0.016	+0.006	—	—
400	500	0	-0.177	—	—	—	—	—	—	—	—	+0.020	+0.018	—	—	—
500	630	0	-0.197	—	—	—	—	—	—	—	—	+0.024	+0.020	—	—	—
630	800	0	-0.295	—	—	—	—	—	—	—	—	+0.028	—	—	—	—
800	1000	0	-0.394	—	—	—	—	—	—	—	—	+0.031	—	—	—	—
1000	1250	0	-0.492	—	—	—	—	—	—	—	—	+0.039	—	—	—	—
1250	1600	0	-0.630	—	—	—	—	—	—	—	—	+0.047	—	—	—	—
1600	2000	0	-0.787	—	—	—	—	—	—	—	—	+0.055	—	—	—	—

Note: 1) Tolerance for width deviation and tolerance limits for the width variation of the outer ring should be the same.
 2) Applicable to individual rings manufactured for combined bearings.
 3) 0.6 mm is included in this group.

Table 10.15 — Tolerances for Inner Ring Runout of Radial Bearings (excluding Tapered Roller Bearings)

Units: inch

Nominal Bore Diameter <i>d</i> (mm)		K_{ia}					S_d			S_{ia} ⁽¹⁾		
		Class N	Class 6	Class 5	Class 4	Class 2	Class 5	Class 4	Class 2	Class 5	Class 4	Class 2
		max	max	max	max	max	max	max	max	max	max	max
over	incl	max	max	max	max	max	max	max	max	max	max	
0.6 ²⁾	2.5	+0.004	+0.002	+0.002	+0.001	+0.001	+0.003	+0.001	+0.001	+0.003	+0.001	+0.001
2.5	10	+0.004	+0.002	+0.002	+0.001	+0.001	+0.003	+0.001	+0.001	+0.003	+0.001	+0.001
10	18	+0.004	+0.003	+0.002	+0.001	+0.001	+0.003	+0.001	+0.001	+0.003	+0.001	+0.001
18	30	+0.005	+0.003	+0.002	+0.001	+0.001	+0.003	+0.002	+0.001	+0.003	+0.002	+0.001
30	50	+0.006	+0.004	+0.002	+0.002	+0.001	+0.003	+0.002	+0.001	+0.003	+0.002	+0.001
50	80	+0.008	+0.004	+0.002	+0.002	+0.001	+0.003	+0.002	+0.001	+0.003	+0.002	+0.001
80	120	+0.010	+0.005	+0.002	+0.002	+0.001	+0.004	+0.002	+0.001	+0.004	+0.002	+0.001
120	150	+0.012	+0.007	+0.003	+0.002	+0.001	+0.004	+0.002	+0.001	+0.004	+0.003	+0.001
150	180	+0.012	+0.007	+0.003	+0.002	+0.002	+0.004	+0.002	+0.002	+0.004	+0.003	+0.002
180	250	+0.016	+0.008	+0.004	+0.003	+0.002	+0.004	+0.003	+0.002	+0.005	+0.003	+0.002
250	315	+0.020	+0.010	+0.005	—	—	+0.005	—	—	+0.006	—	—
315	400	+0.024	+0.012	+0.006	—	—	+0.006	—	—	+0.008	—	—
400	500	+0.026	+0.014	—	—	—	—	—	—	—	—	—
500	630	+0.028	+0.016	—	—	—	—	—	—	—	—	—
630	800	+0.031	—	—	—	—	—	—	—	—	—	—
800	1000	+0.035	—	—	—	—	—	—	—	—	—	—
1000	1250	+0.039	—	—	—	—	—	—	—	—	—	—
1250	1600	+0.047	—	—	—	—	—	—	—	—	—	—
1600	2000	+0.055	—	—	—	—	—	—	—	—	—	—

Note: 1) Applicable to ball bearings only.
 2) 0.6mm is included in this group

Table 10.16 — Tolerances for Outer Ring Runout of Radial Bearings (excluding Tapered Roller Bearings)

Units: inch

Nominal Outside Diameter D (mm)		K_{ea}					S_D			$S_{ea}^{(1)}$			$V_{Cs}^{(2)}$		
		Class					Class			Class			Class		
		N	6	5	4	2	5	4	2	5	4	2	5	4	2
over	incl	max	max	max	max	max	max	max	max	max	max	max	max	max	
2.5 ³⁾	6	+0.006	+0.003	+0.002	+0.001	+0.001	+0.003	+0.002	+0.001	+0.003	+0.002	+0.001	+0.002	+0.001	+0.001
6	18	+0.006	+0.003	+0.002	+0.001	+0.001	+0.003	+0.002	+0.001	+0.003	+0.002	+0.001	+0.002	+0.001	+0.001
18	30	+0.006	+0.004	+0.002	+0.002	+0.001	+0.003	+0.002	+0.001	+0.003	+0.002	+0.001	+0.002	+0.001	+0.001
30	50	+0.008	+0.004	+0.003	+0.002	+0.001	+0.003	+0.002	+0.001	+0.003	+0.002	+0.001	+0.002	+0.001	+0.001
50	80	+0.010	+0.005	+0.003	+0.002	+0.002	+0.003	+0.002	+0.001	+0.004	+0.002	+0.002	+0.002	+0.001	+0.001
80	120	+0.014	+0.007	+0.004	+0.002	+0.002	+0.004	+0.002	+0.001	+0.004	+0.002	+0.002	+0.003	+0.002	+0.001
120	150	+0.016	+0.008	+0.004	+0.003	+0.002	+0.004	+0.002	+0.001	+0.005	+0.003	+0.002	+0.003	+0.002	+0.001
150	180	+0.018	+0.009	+0.005	+0.003	+0.002	+0.004	+0.002	+0.001	+0.006	+0.003	+0.002	+0.003	+0.002	+0.001
180	250	+0.020	+0.010	+0.006	+0.004	+0.003	+0.004	+0.003	+0.002	+0.006	+0.004	+0.003	+0.004	+0.003	+0.002
250	315	+0.024	+0.012	+0.007	+0.004	+0.003	+0.005	+0.003	+0.002	+0.007	+0.004	+0.003	+0.004	+0.003	+0.002
315	400	+0.028	+0.014	+0.008	+0.005	+0.003	+0.005	+0.004	+0.003	+0.008	+0.005	+0.003	+0.005	+0.003	+0.003
400	500	+0.031	+0.016	+0.009	-	-	+0.006	-	-	+0.009	-	-	+0.006	-	-
500	630	+0.039	+0.020	+0.010	-	-	+0.007	-	-	+0.010	-	-	+0.007	-	-
630	800	+0.047	+0.024	+0.012	-	-	+0.008	-	-	+0.012	-	-	+0.008	-	-
800	1000	+0.055	+0.030	-	-	-	-	-	-	-	-	-	-	-	-
1000	1250	+0.063	-	-	-	-	-	-	-	-	-	-	-	-	-
1250	1600	+0.075	-	-	-	-	-	-	-	-	-	-	-	-	-
1600	2000	+0.087	-	-	-	-	-	-	-	-	-	-	-	-	-
2000	2500	+0.098	-	-	-	-	-	-	-	-	-	-	-	-	-

Note: 1) Tolerance for width deviation and tolerance limits for the width variation of the outer ring should be the same bearing.
 2) Applicable to individual rings manufactured for combined bearings.
 3) 2.5mm is included within this group

Introduction
Ball Bearings
Cylindrical Roller Bearings
Spherical Roller Bearings
Tapered Roller Bearings
Thrust Bearings
Split Pillow Blocks
Super Precision Bearings
Linear Motion
Rolling Mill Bearings
Engineering Section

Table 10.17 — Tolerances for Inner Ring Bore Diameter of Metric Tapered Roller Bearings

Units: inch

Nominal Bore Diameter <i>d</i> (mm)		Δdmp						Δds		Vdp				$Vdmp$				
		Class N Class 6X		Class 6 Class 5		Class 4		Class 4		Class				Class				
		over	incl	high	low	high	low	high	low	high	low	N,6X	6	5	4	N,6X	6	5
10	18	0	-.0003	0	-.0003	0	-.0002	0	-.0002	+.0003	+.0003	+.0002	+.0002	+.0002	+.0002	+.0002	+.0002	+.0002
18	30	0	-.0004	0	-.0003	0	-.0002	0	-.0002	+.0004	+.0003	+.0002	+.0002	+.0003	+.0002	+.0002	+.0002	+.0002
30	50	0	-.0005	0	-.0004	0	-.0003	0	-.0003	+.0005	+.0004	+.0003	+.0002	+.0004	+.0003	+.0002	+.0002	+.0002
50	80	0	-.0006	0	-.0005	0	-.0004	0	-.0004	+.0006	+.0005	+.0004	+.0003	+.0004	+.0004	+.0004	+.0002	+.0002
80	120	0	-.0008	0	-.0006	0	-.0004	0	-.0004	+.0008	+.0006	+.0004	+.0003	+.0006	+.0004	+.0003	+.0002	+.0002
120	180	0	-.0010	0	-.0007	0	-.0005	0	-.0005	+.0010	+.0007	+.0006	+.0004	+.0007	+.0006	+.0004	+.0003	+.0003
180	250	0	-.0012	0	-.0009	0	-.0006	0	-.0006	+.0012	+.0009	+.0007	+.0004	+.0009	+.0006	+.0004	+.0003	+.0003
250	315	0	-.0014	0	-.0010	0	-.0007	0	-.0007	+.0014	-	-	-	+.0010	-	-	-	-
315	400	0	-.0016	0	-.0012	0	-.0009	0	-.0009	+.0016	-	-	-	+.0012	-	-	-	-
400	500	0	-.0018	0	-.0014	0	-.0011	0	-.0011	-	-	-	-	-	-	-	-	-
500	630	0	-.0020	0	-.0016	-	-	-	-	-	-	-	-	-	-	-	-	-
630	800	0	-.0030	0	-.0024	-	-	-	-	-	-	-	-	-	-	-	-	-

Remarks: 1. The outside diameter "no-go side" tolerances (high) specified in this table do not necessarily apply within a distance of 1.2 times the chamfer dimension *r* (max) from the ring face.
 2. Some of these tolerances conform to the NSK standard, and not ISO standards.

Table 10.18 — Tolerances for Outer Ring Diameter of Metric Tapered Roller Bearings

Units: inch

Nominal Outside Diameter <i>D</i> (mm)		Δdmp						Δds		Vdp				$Vdmp$				
		Class N Class 6X		Class 6 Class 5		Class 4		Class 4		Class				Class				
		over	incl	high	low	high	low	high	low	high	low	N,6X	6	5	4	N,6X	6	5
18	30	0	-.0004	0	-.0003	0	-.0002	0	-.0002	+.0004	+.0003	+.0002	+.0002	+.0003	+.0002	+.0002	+.0002	+.0002
30	50	0	-.0004	0	-.0004	0	-.0003	0	-.0003	+.0004	+.0004	+.0003	+.0002	+.0003	+.0003	+.0002	+.0002	+.0002
50	80	0	-.0005	0	-.0004	0	-.0004	0	-.0004	+.0005	+.0004	+.0003	+.0003	+.0004	+.0003	+.0002	+.0002	+.0002
80	120	0	-.0006	0	-.0005	0	-.0004	0	-.0004	+.0006	+.0005	+.0004	+.0003	+.0004	+.0004	+.0003	+.0002	+.0002
120	150	0	-.0007	0	-.0006	0	-.0004	0	-.0004	+.0007	+.0006	+.0004	+.0003	+.0006	+.0004	+.0003	+.0002	+.0002
150	180	0	-.0010	0	-.0007	0	-.0005	0	-.0005	+.0010	+.0007	+.0006	+.0004	+.0007	+.0006	+.0004	+.0003	+.0003
180	250	0	-.0012	0	-.0008	0	-.0006	0	-.0006	+.0012	+.0008	+.0006	+.0004	+.0009	+.0006	+.0004	+.0003	+.0003
250	315	0	-.0014	0	-.0010	0	-.0007	0	-.0007	+.0014	+.0010	+.0007	+.0006	+.0010	+.0007	+.0005	+.0004	+.0004
315	400	0	-.0016	0	-.0011	0	-.0008	0	-.0008	+.0016	+.0011	+.0009	+.0006	+.0012	+.0008	+.0006	+.0004	+.0004
400	500	0	-.0018	0	-.0013	0	-.0009	0	-.0009	+.0018	-	-	-	+.0013	-	-	-	-
500	630	0	-.0020	0	-.0015	-	-.0011	-	-.0011	+.0020	-	-	-	+.0015	-	-	-	-
630	800	0	-.0030	0	-.0018	-	-	-	-	-	-	-	-	-	-	-	-	-
800	1000	0	-.0039	0	-.0024	-	-	-	-	-	-	-	-	-	-	-	-	-

Remarks: 1. The outside diameter "no-go side" tolerances (high) specified in this table do not necessarily apply within a distance of 1.2 times the chamfer dimension *r* (max) from the ring face.
 2. Some of these tolerances conform to the NSK standard, and not ISO standards.

Table 10.19 — Tolerances for Inner Ring Running Accuracy of Metric Tapered Bearings

Units: inch

Nominal Bore Diameter d (mm)		K _{ia}				S _d		S _{ia}
		Class N Class 6X	Class 6	Class 5	Class 4	Class 5	Class 4	Class 4
over	incl	max	max	max	max	max	max	max
10	18	+0.0006	+0.0003	+0.0001	+0.0001	+0.0003	+0.0001	+0.0001
18	30	+0.0007	+0.0003	+0.0002	+0.0001	+0.0003	+0.0002	+0.0002
30	50	+0.0008	+0.0004	+0.0002	+0.0002	+0.0003	+0.0002	+0.0002
50	80	+0.0010	+0.0004	+0.0002	+0.0002	+0.0003	+0.0002	+0.0002
80	120	+0.0012	+0.0005	+0.0002	+0.0002	+0.0004	+0.0002	+0.0002
120	180	+0.0014	+0.0007	+0.0003	+0.0002	+0.0004	+0.0002	+0.0003
180	250	+0.0020	+0.0008	+0.0004	+0.0003	+0.0004	+0.0003	+0.0003
250	315	+0.0024	+0.0010	+0.0005	+0.0004	+0.0005	+0.0003	+0.0004
315	400	+0.0028	+0.0012	+0.0006	+0.0005	+0.0006	+0.0004	+0.0006
400	500	+0.0028	+0.0014	+0.0007	+0.0006	+0.0007	+0.0005	+0.0007
500	630	+0.0033	+0.0016	+0.0008	--	+0.0009	--	--
630	800	+0.0039	+0.0018	+0.0009	--	+0.0011	--	--

Table 10.20 — Tolerances for Outer Ring Running Accuracy of Metric Tapered Bearings

Units: inch

Nominal Outside Diameter D (mm)		K _{ea}				S _D		S _{ea}
		Class N Class 6X	Class 6	Class 5	Class 4	Class 5	Class 4	Class 4
over	incl	max	max	max	max	max	max	max
18	30	+0.0007	+0.0004	+0.0002	+0.0002	+0.0003	+0.0002	+0.0002
30	50	+0.0008	+0.0004	+0.0003	+0.0002	+0.0003	+0.0002	+0.0002
50	80	+0.0010	+0.0005	+0.0003	+0.0002	+0.0003	+0.0002	+0.0002
80	120	+0.0014	+0.0007	+0.0004	+0.0002	+0.0004	+0.0002	+0.0002
120	150	+0.0016	+0.0008	+0.0004	+0.0003	+0.0004	+0.0002	+0.0003
150	180	+0.0018	+0.0009	+0.0005	+0.0003	+0.0004	+0.0002	+0.0003
180	250	+0.0020	+0.0010	+0.0006	+0.0004	+0.0004	+0.0003	+0.0004
250	315	+0.0024	+0.0012	+0.0007	+0.0004	+0.0005	+0.0003	+0.0004
315	400	+0.0028	+0.0014	+0.0008	+0.0005	+0.0005	+0.0004	+0.0005
400	500	+0.0031	+0.0016	+0.0009	+0.0006	+0.0006	+0.0004	+0.0006
500	630	+0.0039	+0.0020	+0.0010	+0.0007	+0.0007	+0.0005	+0.0007
630	800	+0.0047	+0.0024	+0.0012	--	+0.0008	--	--
800	1000	+0.0047	+0.0030	+0.0014	--	+0.0009	--	--

Introduction

Ball Bearings

Cylindrical Roller Bearings

Spherical Roller Bearings

Tapered Roller Bearings

Thrust Bearings

Split Pillow Blocks

Super Precision Bearings

Linear Motion

Rolling Mill Bearings

Engineering Section

Table 10.21 — Tolerances for Cone Width, Cup Width, and Combined Cone/Cup Width of Metric Tapered Roller Bearings



Units: inch

Nominal Bore Diameter <i>d</i> (mm)		ΔB_s						ΔC_s						ΔT_s					
		Class N Class 6		Class 6X		Class 5 Class 4		Class N Class 6		Class 6X		Class 5 Class 4		Class N Class 6		Class 6X		Class 5 Class 4	
over	incl	high	low	high	low	high	low	high	low	high	low	high	low	high	low	high	low	high	low
10	18	0	-0.0047	0	-0.0020	0	-0.0079	0	-0.0047	0	-0.0039	0	-0.0079	-0.0079	0	+0.0039	0	+0.0079	-0.0079
18	30	0	-0.0047	0	-0.0020	0	-0.0079	0	-0.0047	0	-0.0039	0	-0.0079	-0.0079	0	+0.0039	0	+0.0079	-0.0079
30	50	0	-0.0047	0	-0.0020	0	-0.0094	0	-0.0047	0	-0.0039	0	-0.0094	-0.0079	0	+0.0039	0	+0.0079	-0.0079
50	80	0	-0.0059	0	-0.0020	0	-0.0118	0	-0.0059	0	-0.0039	0	-0.0118	-0.0079	0	+0.0039	0	+0.0079	-0.0079
80	120	0	-0.0079	0	-0.0020	0	-0.0157	0	-0.0079	0	-0.0039	0	-0.0157	+0.0079	-0.0079	+0.0039	0	+0.0079	-0.0079
120	180	0	-0.0098	0	-0.0020	0	-0.0197	0	-0.0098	0	-0.0039	0	-0.0197	+0.0138	-0.0098	+0.0059	0	+0.0138	-0.0098
180	250	0	-0.0118	0	-0.0020	0	-0.0197	0	-0.0118	0	-0.0039	0	-0.0197	+0.0138	-0.0098	+0.0059	0	+0.0209	-0.0098
250	315	0	-0.0138	0	-0.0020	0	-0.0276	0	-0.0138	0	-0.0039	0	-0.0276	+0.0138	-0.0098	+0.0079	0	+0.0209	-0.0098
315	400	0	-0.0157	0	-0.0020	0	-0.0315	0	-0.0157	0	-0.0039	0	-0.0315	+0.0157	-0.0157	+0.0079	0	+0.0157	-0.0157
400	500	0	-0.0177	-	-	0	-0.0315	0	-0.0177	-	-	0	-0.0315	+0.0157	-0.0157	-	-	+0.0157	-0.0157
500	630	0	-0.0197	-	-	0	-0.0315	0	-0.0197	-	-	0	-0.0315	+0.0197	-0.0197	-	-	+0.0197	-0.0197
630	800	0	-0.0295	-	-	0	-0.0315	0	-0.0295	-	-	0	-0.0315	+0.0236	-0.0236	-	-	+0.0236	-0.0236

Remarks: 1. The effective width of a cone with rollers T1 is defined as the overall bearing width of a cone with rollers combined with a master cup.
 2. The effective width of a cup T2 is defined as the overall bearing width of a cup combined with a master cone with rollers.

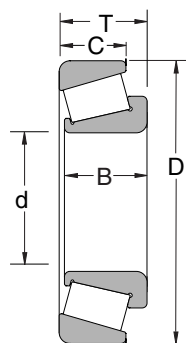

Single Row

Introduction
 Ball Bearings
 Cylindrical Roller Bearings
 Spherical Roller Bearings
 Tapered Roller Bearings
 Thrust Bearings
 Split Pillow Blocks
 Super Precision Bearings
 Linear Motion
 Rolling Mill Bearings
 Engineering Section

Table 10.21 — Tolerances for Cone Width, Cup Width, and Combined Cone/Cup Width(continued)

Units: inch

Nominal Bore Diameter d (mm)		Effective Cone Width (with Rollers) Deviation ΔT_{1s}				Effective Cup Width Deviation ΔT_{2s}				Overall Combined Bearing Width Deviation			
		Class N		Class 6X		Class N		Class 6X		ΔB_{2s}		$\Delta B_{4s}, \Delta C_{4s}$	
		high	low	high	low	high	low	high	low	high	low	high	low
10	18	+0.0039	0	+0.0020	0	+0.0039	0	+0.0020	0	+0.0079	-0.0079	-	-
18	30	+0.0039	0	+0.0020	0	+0.0039	0	+0.0020	0	+0.0079	-0.0079	-	-
30	50	+0.0039	0	+0.0020	0	+0.0039	0	+0.0020	0	+0.0079	-0.0079	-	-
50	80	+0.0039	0	+0.0020	0	+0.0039	0	+0.0020	0	+0.0118	-0.0118	+0.0118	-0.0118
80	120	+0.0039	-0.0039	+0.0020	0	+0.0039	-0.0039	+0.0020	0	+0.0118	-0.0118	+0.0157	-0.0157
120	180	+0.0059	-0.0059	+0.0020	0	+0.0079	-0.0039	+0.0039	0	+0.0157	-0.0157	+0.0197	-0.0197
180	250	+0.0059	-0.0059	+0.0020	0	+0.0079	-0.0039	+0.0039	0	+0.0177	-0.0177	+0.0236	-0.0236
250	315	+0.0059	-0.0059	+0.0039	0	+0.0079	-0.0039	+0.0039	0	+0.0217	-0.0217	+0.0276	-0.0276
315	400	+0.0079	-0.0079	+0.0039	0	+0.0079	-0.0079	+0.0039	0	+0.0236	-0.0236	+0.0315	-0.0315
400	500	-	-	-	-	-	-	-	-	+0.0276	-0.0276	+0.0354	-0.0354
500	630	-	-	-	-	-	-	-	-	+0.0315	-0.0315	+0.0394	-0.0394
630	800	-	-	-	-	-	-	-	-	+0.0472	-0.0472	+0.0591	-0.0591

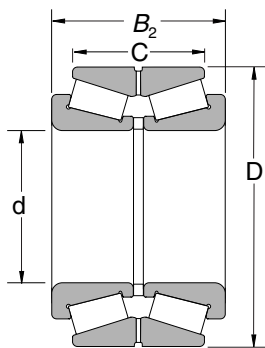

KBE Type

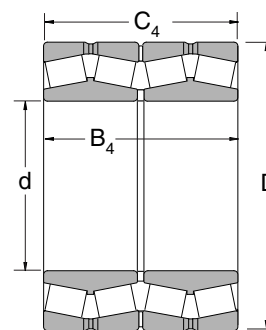

KV Type

Introduction

Ball Bearings

Cylindrical Roller Bearings

Spherical Roller Bearings

Tapered Roller Bearings

Thrust Bearings

Split Pillow Blocks

Super Precision Bearings

Linear Motion

Rolling Mill Bearings

Engineering Section

Table 10.22 —Tolerances for Outer Ring Outside Diameter and Radial Runout of Inch Tapered Roller Bearings



Units: inch

Nominal Outside Diameter <i>D</i> (in)		ΔD_s					
		Class 4,2		Class 3,0		Class 00	
over	incl.	high	low	high	low	high	low
10.5000	12.0000	+0.010	0	+0.0005	0	+0.0003	0
12.0000	24.0000	+0.010	0	+0.0005	0	—	—
24.0000	36.0000	+0.020	0	+0.0010	0	—	—
36.0000	48.0000	+0.030	0	+0.0015	0	—	—
		+0.040	0	+0.0020	0	—	—
		+0.050	0	+0.0030	0	—	—

Table 10.23 — Tolerances for Overall Width and Combined Width of Inch Tapered Roller Bearings



Units: inch

Nominal Bore Diameter <i>d</i> (in)		ΔT_s									
		Class 4		Class 2		Class 3,0				Class 0 Class 00	
						$D \leq 508.000\text{mm}$		$D > 508.000\text{mm}$			
over	incl.	high	low	high	low	high	low	high	low	high	low
4.0000	12.0000	+0.0080	—	+0.0080	—	+0.0080	-.0080	+0.0080	-.0080	+0.0080	-.0080
12.0000	24.0000	+0.0140	-.0100	+0.0080	—	+0.0080	-.0080	+0.0080	-.0080	+0.0080	-.0080
24.0000		+0.0150	-.0150	+0.0150	-.0150	+0.0080	-.0080	+0.0150	-.0150	—	—
		+0.0150	-.0150	—	—	+0.0150	-.0150	+0.0150	-.0150	—	—

Table 10.24 — Tolerances for Inner Ring Bore of Inch Design Tapered Roller Bearings

Units: inch

Nominal Bore Diameter <i>d</i> (in)		Δd_s					
		Class 4,2		Class 3,0		Class 00	
over	incl.	high	low	high	low	high	low
3.0000	10.5000	+0.0005	0	+0.0005	0	+0.0003	0
10.5000	12.0000	+0.0010	0	+0.0005	0	+0.0003	0
12.0000	24.0000	+0.0010	0	+0.0005	0	—	—
24.0000	36.0000	+0.0020	0	+0.0010	0	—	—
36.0000	48.0000	+0.0030	0	+0.0015	0	—	—
48.0000		+0.0040	0	+0.0020	0	—	—
		+0.0050	0	+0.0030	0	—	—

Introduction
Ball Bearings
Cylindrical Roller Bearings
Spherical Roller Bearings
Tapered Roller Bearings
Thrust Bearings
Split Pillow Blocks
Super Precision Bearings
Linear Motion
Rolling Mill Bearings
Engineering Section

Table 10.22 —Tolerances for Outer Ring Outside Diameter and Radial Runout of Inch Tapered Roller Bearings (continued)

Units: inch

K_{ia}, K_{ea}				
Class 4	Class 2	Class 3	Class 0	Class 00
max	max	max	max	max
.0020	.0015	.0003	.0002	.0001
.0020	.0015	.0003	.0002	—
.0020	.0015	.0003	—	—
.0030	.0020	.0020	—	—
.0030	—	.0030	—	—
.0030	—	.0030	—	—

Table 10.23 —Tolerances for Overall Width and Combined Width of Inch Tapered Roller Bearings (continued)

Units: inch

Double-Row Bearings (KBE Type) ΔB_{2s}										Four-Row Bearings (KV Type) $\Delta B_{4s}, \Delta C_{4s}$	
Class 4		Class 2		Class 3,0				Class 0,00		Class 4,3,0	
				$D \leq 508.000\text{mm}$		$>508.000\text{mm}$					
high	low	high	low	high	low	high	low	high	low	high	low
+.0160	0	+.0160	0	+.0160	-.0160	+.0160	-.0160	+.0160	-.0160	+.0600	-.0600
+.0280	-.0200	+.0160	-.0080	+.0160	-.0160	+.0160	-.0160	+.0160	-.0160	+.0600	-.0600
+.0300	-.0300	+.0300	-.0300	+.0160	-.0160	+.0308	-.0308	—	—	+.0600	-.0600
+.0300	-.0300	—	—	+.0300	-.0300	+.0308	-.0308	—	—	+.0600	-.0600

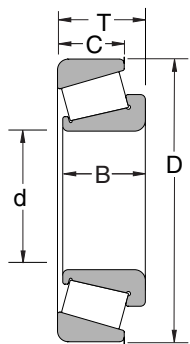

Single Row

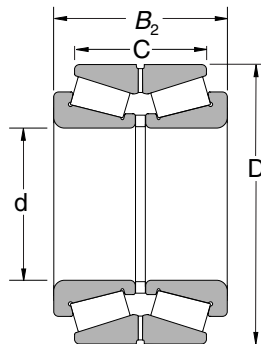

KBE Type

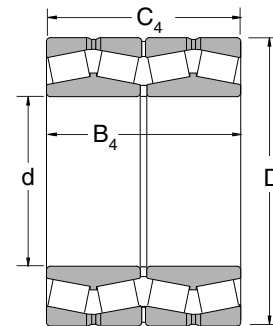

KV Type

Table 10.25 —Tolerances for Shaft Washer Bore Diameter and Running Accuracy of Thrust Ball Bearings

Units: inch

Nominal Bore Diameter d or d ₂ (mm)		Δd _{mp} or Δd _{2mp}				V _{d_p} or V _{d_{2p}}		S _i or S _e ¹⁾			
		Class N,6,5		Class 4		max	max	Class N	Class 6	Class 5	Class 4
		over	incl	high	low						
18	18	0	-0.0003	0	-0.0003	.0002	.0002	.0004	.0002	.0001	.0001
30	30	0	-0.0004	0	-0.0003	.0003	.0002	.0004	.0002	.0001	.0001
50	50	0	-0.0005	0	-0.0004	.0004	.0003	.0004	.0002	.0001	.0001
80	80	0	-0.0006	0	-0.0005	.0004	.0004	.0004	.0003	.0002	.0001
120	120	0	-0.0008	0	-0.0006	.0006	.0004	.0006	.0003	.0002	.0001
180	180	0	-0.0010	0	-0.0007	.0007	.0006	.0006	.0004	.0002	.0002
250	250	0	-0.0012	0	-0.0009	.0009	.0007	.0008	.0004	.0002	.0002
315	315	0	-0.0014	0	-0.0010	.0010	.0007	.0010	.0005	.0003	.0002
400	400	0	-0.0016	0	-0.0012	.0012	.0009	.0012	.0006	.0003	.0002
500	500	0	-0.0018	0	-0.0014	.0013	.0010	.0012	.0007	.0004	.0002
630	630	0	-0.0020	0	-0.0016	.0015	.0012	.0014	.0008	.0004	.0003
800	800	0	-0.0030	0	-0.0020	—	—	.0016	.0010	.0005	.0003
1000	1000	0	-0.0039	—	—	—	—	.0018	.0012	.0006	—
1250	1250	0	-0.0049	—	—	—	—	.0020	.0014	.0007	—

Note: 1) For double-direction bearings, the thickness variation doesn't depend on the bore diameter d₂, but on d for single-direction bearings with the same D in the same diameter series.
 Remarks: The thickness variation of housing washers, S_e, applies only to flat-seat thrust bearings

Table 10.26 —Tolerances for Outside Diameter of Housing Washers and Aligning Seat Washers of Thrust Ball Bearings

Units: inch

Nominal Outside Diameter of Bearing or Aligning Seat Washer D or D ₃ (mm)		ΔD _{mp}						V _{D_p}		Aligning Seat Washer Outside Diameter Deviation ΔD _{3s}	
		Flat Seat Type				Aligning Seat Washer Type		Class N,6,5	Class 4	Class N,6	
		over	incl	high	low	high	low			high	low
10	18	0	-0.0004	0	-0.0003	0	-0.0007	+0.0003	+0.0002	0	-0.0010
18	30	0	-0.0005	0	-0.0003	0	-0.0008	+0.0004	+0.0002	0	-0.0012
30	50	0	-0.0006	0	-0.0004	0	-0.0009	+0.0005	+0.0003	0	-0.0014
50	80	0	-0.0007	0	-0.0004	0	-0.0011	+0.0006	+0.0003	0	-0.0018
80	120	0	-0.0009	0	-0.0005	0	-0.0013	+0.0007	+0.0004	0	-0.0024
120	180	0	-0.0010	0	-0.0006	0	-0.0015	+0.0007	+0.0004	0	-0.0030
180	250	0	-0.0012	0	-0.0008	0	-0.0018	+0.0009	+0.0006	0	-0.0035
250	315	0	-0.0014	0	-0.0010	0	-0.0021	+0.0010	+0.0007	0	-0.0041
315	400	0	-0.0016	0	-0.0011	0	-0.0024	+0.0012	+0.0008	0	-0.0047
400	500	0	-0.0018	0	-0.0013	0	-0.0027	+0.0013	+0.0010	0	-0.0053
500	630	0	-0.0020	0	-0.0015	0	-0.0030	+0.0015	+0.0011	0	-0.0071
630	800	0	-0.0030	0	-0.0018	0	-0.0044	+0.0022	+0.0013	0	-0.0089
800	1000	0	-0.0039	—	—	—	—	+0.0030	—	—	—
1000	1250	0	-0.0049	—	—	—	—	—	—	—	—
1250	1600	0	-0.0063	—	—	—	—	—	—	—	—

Introduction
Ball Bearings
Cylindrical Roller Bearings
Spherical Roller Bearings
Tapered Roller Bearings
Thrust Bearings
Split Pillow Blocks
Super Precision Bearings
Linear Motion
Rolling Mill Bearings
Engineering Section

Table 10.27 —Tolerances for Thrust Ball Bearing Height and Central Washer Height

Units: inch

Nominal Bore Diameter d (mm)		Flat Seat Type				Aligning Seat Washer Type				With Aligning Seat Washer				Height Deviation of Central Washer ΔB_s	
		ΔT_s or ΔT_{2s}		ΔT_{1s}		ΔT_{3s} or ΔT_{5s}		ΔT_{5s}		ΔT_{4s} or ΔT_{8s}		ΔT_{1s}			
		Class N,6,5,4		Class N,6,5,4		Class N,6		Class N,6		Class N,6		Class N,6		Class N,6,5,4	
over	incl	high	low	high	low	high	low	high	low	high	low	high	low	high	low
30	30	+0	-0.0030	+0.0020	-0.0059	+0	-0.0030	+0.0020	-0.0059	+0.0020	-0.0030	+0.0059	-0.0059	+0	-0.0020
50	50	+0	-0.0039	+0.0030	-0.0079	+0	-0.0039	+0.0030	-0.0079	+0.0020	-0.0039	+0.0069	-0.0079	+0	-0.0030
80	80	+0	-0.0049	+0.0039	-0.0098	+0	-0.0049	+0.0039	-0.0098	+0.0030	-0.0049	+0.0098	-0.0098	+0	-0.0039
120	120	+0	-0.0059	+0.0049	-0.0118	+0	-0.0059	+0.0049	-0.0118	+0.0030	-0.0059	+0.0108	-0.0118	+0	-0.0049
180	180	+0	-0.0069	+0.0059	-0.0138	+0	-0.0069	+0.0059	-0.0138	+0.0039	-0.0069	+0.0138	-0.0138	+0	-0.0059
250	250	+0	-0.0079	+0.0069	-0.0157	+0	-0.0079	+0.0069	-0.0157	+0.0039	-0.0079	+0.0148	-0.0157	+0	-0.0069
315	315	+0	-0.0089	+0.0079	-0.0177	+0	-0.0089	+0.0079	-0.0177	+0.0049	-0.0089	+0.0177	-0.0177	+0	-0.0079
315	400	+0	-0.0118	+0.0098	-0.0236	+0	-0.0118	+0.0098	-0.0236	+0.0059	-0.0108	+0.0217	-0.0217	+0	-0.0098

Note: 1) For double-direction bearings, the thickness variation doesn't depend on the bore diameter d_2 , but on d for single-direction bearings with the same D in the same diameter series.

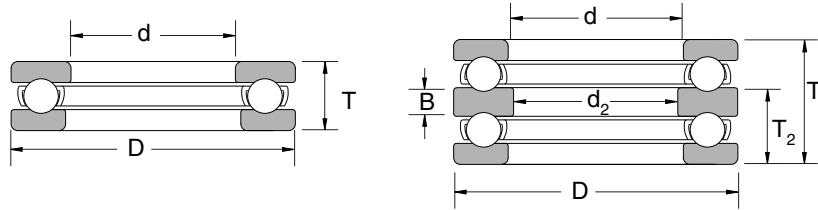

Introduction

Ball Bearings

Cylindrical Roller Bearings

Spherical Roller Bearings

Tapered Roller Bearings

Thrust Bearings

Split Pillow Blocks

Super Precision Bearings

Linear Motion

Rolling Mill Bearings

Engineering Section

Table 10.28 —Tolerances for Bore Diameters of Inner Rings and Height (Class N) of Spherical Thrust Roller Bearings

Units: inch

Nominal Bore Diameter d (mm)		Δd_{mp}		V_{dp}	Reference		
					S_d	ΔT_s	
over	incl	high	low	max	high	low	
50	80	0	-.0006	.0004	.0010	+.0059	-.0059
80	120	0	-.0008	.0006	.0010	+.0079	-.0079
120	180	0	-.0010	.0007	.0012	+.0098	-.0098
180	250	0	-.0012	.0009	.0012	+.0118	-.0118
250	315	0	-.0014	.0010	.0014	+.0138	-.0138
315	400	0	-.0016	.0012	.0016	+.0157	-.0157
400	500	0	-.0018	.0013	.0018	+.0177	-.0177

Table 10.29 —Tolerances for Outer Ring Diameter (Class N) of Spherical Thrust Roller Bearings

Units: inch

Nominal Outside Diameter D (mm)		ΔD_{mp}	
		high	low
over	incl	high	low
120	180	0	-.0010
180	250	0	-.0012
250	315	0	-.0014
315	400	0	-.0016
400	500	0	-.0018
500	630	0	-.0020
630	800	0	-.0030
800	1000	0	-.0039

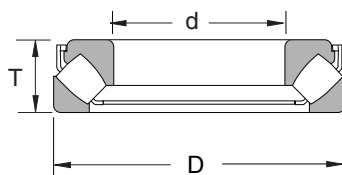

Introduction
Ball Bearings
Cylindrical Roller Bearings
Spherical Roller Bearings
Tapered Roller Bearings
Thrust Bearings
Split Pillow Blocks
Super Precision Bearings
Linear Motion
Rolling Mill Bearings
Engineering Section

Bearing Fits & Internal Clearance

Fit--Why It's Important

When a bearing's inner ring is fitted to the shaft with only slight interference, slipping or "creep" may occur. Creep may also occur between the outer ring and housing.

When creep occurs the fitted surfaces become abraded which causes excessive wear and may cause considerable damage to the shaft or housing. In addition, abrasive metal particles resulting from creep may enter the interior of the bearing and cause abnormal heating and vibration.

It is important to prevent creep by having sufficient interference to firmly secure the bearing ring to either the shaft or housing.

In specific applications, fits can be made without interference. For example, it is usually not necessary to provide fit interference for rings subjected only to stationary loads. In other applications, loose fits may be used to accommodate certain operating conditions or to facilitate bearing mounting and dismounting. In these cases, lubrication or other methods need to be considered to prevent damage to the fitting surfaces due to creep.

Table 10.30 —Loading Conditions and Fit

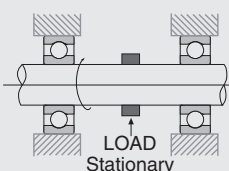
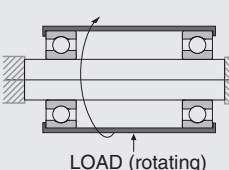
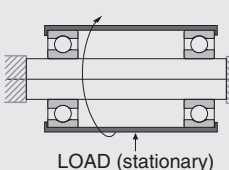
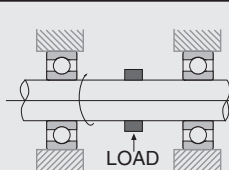
Load Application	Bearing Operation		Loading Conditions	Fit	
	Inner Ring	Outer Ring		Inner Ring and Shaft	Outer Ring and Housing
	Rotating	Stationary	Rotating Inner Ring Load	Tight Fit	Loose Fit
	Stationary	Rotating	Stationary Outer Ring Load		
	Stationary	Rotating	Rotating Outer Ring Load	Loose Fit	Tight Fit
	Rotating	Stationary	Stationary Inner Ring Load		
Direction of Load Indeterminate	Rotating or Stationary	Rotating or Stationary	-	Tight Fit	Tight Fit

How To Select Proper Fit

Load Conditions and Fit

Proper fit may be selected from Table 10.30 on page 327 based on the load and operating conditions.

Magnitude of Load and Interference

Under load, a slight amount of deflection or deformation of the bearing rings will occur. This reduces the interference fit. For this reason, heavier loaded bearings require a heavier initial interference fit. The required interference can be calculated using the following equations:

$$\Delta d_f = 0.08 \sqrt{\frac{d}{B} F_r} \times 10^{-3} \quad \Delta d_e \geq 0.02 \frac{F_r}{B} \times 10^{-3}$$

Where Δd_f : Interference decrease of inner ring (mm)
 Δd_e : Effective interference (mm)
 d : Bearing bore diameter (mm)
 B : Inner ring width (mm)
 F_r : Radial load applied to bearing (N)

light and normal loads when $F_r > .20 C_{or}$

Interference Variation Due to Temperature Difference Between Bearing and Shaft or Housing

Interference decreases when bearing temperature increases during operation. If the temperature difference between the interior of the bearing and the surrounding parts of the housing is $\Delta T(^{\circ}\text{C})$, then the temperature difference between the fitted surfaces of the shaft and the inner ring is estimated to be about $(0.1 \sim 0.15)T$. Decrease of inner ring interference due to this difference may be calculated from the following equation: $\Delta d_T = (0.10 \sim 0.15)\Delta T \cdot \alpha \cdot d = 0.0015\Delta T \cdot d \times 10^{-3}$

Where Δd_T = Decrease of interference of inner ring due to temperature increase (mm)
 ΔT = Temperature difference between bearing and surrounding parts
 α = Coefficient of linear expansion of bearing steel ($12.5 \times 10^{-6}(1/^{\circ}\text{C})$)
 d = bore diameter

Table 10.31 — Fits of Radial Bearings with Solid Steel Shafts

Load Conditions	Examples	Shaft Diameter (mm)			Tolerance of Shaft	
		Ball Bearings	Cylindrical or Tapered Roller Brgs.	Spherical Roller Bearings		
Radial Bearings with Cylindrical Bores						
Rotating Outer Ring Load	Easy axial displacement of inner ring on shaft desirable	Wheels on Stationary axles	All Shaft Diameters			g6
	Easy axial displacement of inner ring on shaft unnecessary	Tension Pulleys, Rope Sheaves				h6
Rotating Inner Ring Load or Direction of Load Indeterminate	Light Load (<0.06C _r ¹)	Electrical Appliances, Pumps, Blowers, Transport Vehicles, Precision Machinery, Machine Tools	<18	–	–	js5
			18 to 100	<40	–	js6 (j6)
			100 to 200	40 to 140	–	K6
	Normal Loads (0.06 to 0.13 C _r ¹)	General Bearing Applications, Medium and Large Motors, Turbines, Pumps, Engine Main Bearings, Gears, Woodworking Machines	–	140 to 200	–	m6
			<18	–	–	js5-6(j5-6)
			18 to 100	<40	<40	k5 or 6
			100 to 140	40 to 100	40 to 65	m5 or 6
			140 to 200	100 to 140	65 to 100	m6
			200 to 280	140 to 200	100 to 140	n6
			–	200 to 400	140 to 280	p6
	–	–	280 to 500	r6		
	Heavy Loads (>0.13C _r ¹)	Railway Axle boxes, Industrial Vehicles, Traction Motors, Construction Equipment, Crushers	–	–	>500	r7
			–	50 to 140	50 to 100	n6
–			140 to 200	100 to 140	p6	
–			over 200	140 to 200	r6	
–	–	200 to 500	r7			
Axial Loads Only	–	–	All Shaft Diameters		js6 (j6)	
Radial Bearings with Tapered Bores and Sleeves (Contact NSK Engineering)						

Note:1. C_r represents the basic load rating of the bearing

Table 10.32 — Fits of Thrust Bearings with Solid Steel Shafts

For more information, see page 356

Load Conditions		Examples	Shaft Diameter (mm)	Tolerance of Shaft
Central Axial Load Only		Main Shafts of Lathes	All Shaft Diameters	h6 or js6 (j6)
Combined Radial and Axial Loads (Spherical Thrust Roller Bearings)	Stationary Inner Ring Load	Cone Crushers	All Shaft Diameters	js6(j6)
	Rotating Inner Ring Load or Direction of Load Indeterminate	Paper Pulp Refiners, Plastic Extruders	<200	k6
			200 to 400	m6
			Over 400	n6

Table 10.33 — Fits of Radial Bearings with Housings

For more information, see page 358

Load Conditions			Examples	Tolerances for Housing Bores
Solid Housings	Rotating Outer Ring Load	Heavy Loads on Bearing in Thin-Walled Housing or Heavy Shock Loads	Automotive Wheel Hubs (Roller Bearings) Crane Traveling Wheels	P7
		Normal or Heavy Loads	Automotive Wheel Hubs (Ball Bearings) Vibrating Screens	N7
		Light or Variable Loads	Conveyor Roller, Rope Sheaves, Tension Pulleys	M7
	Direction of Load Indeterminate	Heavy Shock Loads	Traction Motors	M7
		Normal or Heavy Loads	Pumps, Crankshaft Main Bearings, Medium and Large Motors	K7
		Normal or Light Loads		JS7 (J7)
Solid or Split Housings	Rotating Inner Ring Load	Loads of All Kinds	General Bearing Applications, Railway Axleboxes	H7
		Normal and Light Loads	Plummer Blocks	H8
		High Temperature Rise of Inner Ring Through Shaft	Paper Dryers	G7
		Accurate Running Desirable Under Normal and Light Loads	Grinding Spindle Rear Ball Bearings, High Speed Centrifugal Compressor Free Bearings	JS6(J6)
Solid Housings	Direction of Load Indeterminate	Accurate Running at High Rigidity Desirable under Variable Loads	Grinding Spindle Front Ball Bearings, High Speed Centrifugal Compressor Fixed Bearings	K6
			Cylindrical Roller Bearings for Machine Tool Main Spindle	M6 or N6
	Rotating Inner Ring Load	Minimum noise is required	Electrical Home Appliances	H6

Table 10.34 — Fits of Thrust Bearings with Housings

For more information, see page 358

Load Conditions		Remarks	Tolerances for Housing Bores	
Axial Loads Only	Thrust Ball Bearings	General Purpose Application	Clearance over 0.25mm	
		When Precision is Required	H8	
	Spherical Thrust Roller Bearings	When Radial Loads are Sustained by Other Bearings	Outer ring has radial clearance	
Combined Radial and Axial Loads	Stationary Outer Ring Loads	Spherical Thrust Roller Bearings	-	
	Rotating Outer Ring Loads or Direction of Load Indeterminate		Normal Loads	K7
			Relatively Heavy Radial Loads	M7

Introduction

Ball Bearings

Cylindrical Roller Bearings

Spherical Roller Bearings

Tapered Roller Bearings

Thrust Bearings

Split Pillow Blocks

Super Precision Bearings

Linear Motion

Rolling Mill Bearings

Engineering Section

Bearing Internal Clearance

Internal Clearances and Standards

Bearing internal clearance is the total clearance between the rings and rolling elements. Internal clearance influences fatigue life, vibration, noise, and operating temperature. Therefore, selection of the proper clearance is critical.

Radial and axial clearances are defined as the total amount that one ring can be displaced relative to the other in either the radial or axial direction as shown in this drawing.

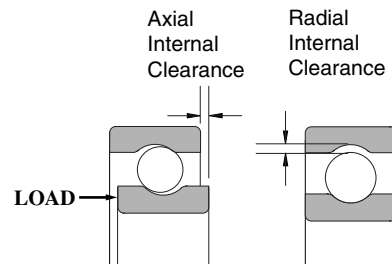

To obtain accurate measurements for ball bearings, internal clearance is usually measured by applying a specified measuring load to the bearings. The clearance measured is always slightly larger than the actual bearing internal clearance due to the elastic deformation caused by the measuring load.

Actual internal clearance is obtained by correcting the measured clearance by the amount of elastic deformation. In the case of roller bearings this elastic deformation is negligible.

Bearing internal clearances listed throughout this catalog have been corrected to provide actual internal clearances.

Radial Internal Clearance

Radial Internal Clearances for several types of ball bearings and roller bearings are presented in the following tables:

Table 10.35 — Radial Internal Clearance in Single Row Deep Groove Ball Bearings Under No Load

Units: inch

Nominal Bore Diameter d (mm)		Radial Internal Clearance							
		C2		C0		C3		C4	
over	incl	low	high	low	high	low	high	low	high
(10mm Only)*		+0.000	+0.003	+0.001	+0.005	+0.003	+0.009	+0.006	+0.011
10	18	+0.000	+0.004	+0.001	+0.007	+0.004	+0.010	+0.007	+0.013
18	24	+0.000	+0.004	+0.002	+0.008	+0.005	+0.011	+0.008	+0.014
24	30	+0.000	+0.004	+0.002	+0.008	+0.005	+0.011	+0.009	+0.016
30	40	+0.000	+0.004	+0.002	+0.008	+0.006	+0.013	+0.011	+0.018
40	50	+0.000	+0.004	+0.002	+0.009	+0.007	+0.014	+0.012	+0.020
50	65	+0.000	+0.006	+0.003	+0.011	+0.009	+0.017	+0.015	+0.024
65	80	+0.000	+0.006	+0.004	+0.012	+0.010	+0.020	+0.018	+0.028
80	100	+0.000	+0.007	+0.005	+0.014	+0.012	+0.023	+0.021	+0.033
100	120	+0.001	+0.008	+0.006	+0.016	+0.014	+0.026	+0.024	+0.038
120	140	+0.001	+0.009	+0.007	+0.019	+0.016	+0.032	+0.028	+0.045
140	160	+0.001	+0.009	+0.007	+0.021	+0.018	+0.036	+0.032	+0.051
160	180	+0.001	+0.010	+0.008	+0.024	+0.021	+0.040	+0.036	+0.058
180	200	+0.001	+0.012	+0.010	+0.028	+0.025	+0.046	+0.042	+0.064
200	225	—	+0.013	+0.010	+0.0315	+0.029	+0.053	+0.049	+0.074
225	250	—	+0.014	+0.012	+0.035	+0.033	+0.059	+0.057	+0.084
250	280	—	+0.016	+0.014	+0.037	+0.035	+0.063	+0.061	+0.092
280	315	—	+0.020	+0.020	+0.043	+0.043	+0.071	+0.075	+0.104
315	355	—	+0.022	+0.022	+0.049	+0.049	+0.079	+0.085	+0.116
355	400	—	+0.026	+0.026	+0.055	+0.055	+0.089	+0.096	+0.134

*For bore sizes smaller than 10mm, refer to Table 10.36

Table 10.36 — Radial Internal Clearances in Extra Small & Miniature Ball Bearings Under No Load

Units: inch

Clearance Symbols (Among these NSK Standard Clearances, MC5 is the most widely used)											
MC1		MC2		MC3		MC4		MC5		MC6	
low	high	low	high	low	high	low	high	low	high	low	high
+0	+0.002	+0.001	+0.003	+0.002	+0.004	+0.003	+0.005	+0.005	+0.008	+0.008	+0.011

Table 10.37 — Radial Internal Clearances in Cylindrical Roller Bearings with Cylindrical Bores

Units: μm

Nominal Bore Dia. $d(\text{mm})$		Clearances in Interchangeable Bearings with Cylindrical Bores										Clearances in Matched Bearings with Cylindrical Bores											
		C2		C0		C3		C4		C5		CC1		CC2		CC(1)		CC3		CC4		CC5	
over	incl	min	max	min	max	min	max	min	max	min	max	min	max	min	max	min	max	min	max	min	max	min	max
0	10	.0000	.0010	.0008	.0018	.0014	.0024	.0020	.0030	-	-	-	-	-	-	-	-	-	-	-	-	-	-
10	24	.0000	.0010	.0008	.0018	.0014	.0024	.0020	.0030	.0026	.0035	.0002	.0006	.0004	.0008	.0008	.0012	.0014	.0018	.0018	.0022	.0026	.0030
24	30	.0000	.0010	.0008	.0018	.0014	.0024	.0020	.0030	.0028	.0037	.0002	.0006	.0004	.0010	.0010	.0014	.0016	.0020	.0020	.0024	.0028	.0031
30	40	.0002	.0012	.0010	.0020	.0018	.0028	.0024	.0033	.0031	.0041	.0002	.0006	.0005	.0010	.0010	.0016	.0018	.0022	.0022	.0028	.0031	.0037
40	50	.0002	.0014	.0012	.0024	.0020	.0031	.0028	.0039	.0037	.0049	.0002	.0007	.0006	.0012	.0012	.0018	.0020	.0026	.0026	.0031	.0037	.0043
50	65	.0004	.0016	.0016	.0028	.0024	.0035	.0031	.0043	.0039	.0055	.0002	.0008	.0006	.0014	.0014	.0020	.0022	.0030	.0030	.0035	.0043	.0051
65	80	.0004	.0018	.0016	.0030	.0026	.0039	.0035	.0049	.0051	.0065	.0004	.0010	.0008	.0016	.0016	.0024	.0028	.0035	.0035	.0043	.0051	.0059
80	100	.0006	.0020	.0020	.0033	.0030	.0043	.0041	.0055	.0061	.0075	.0004	.0012	.0010	.0018	.0018	.0028	.0031	.0041	.0041	.0049	.0061	.0071
100	120	.0006	.0022	.0020	.0035	.0033	.0049	.0049	.0065	.0071	.0087	.0004	.0012	.0010	.0020	.0020	.0031	.0037	.0047	.0047	.0057	.0071	.0081
120	140	.0006	.0024	.0024	.0041	.0039	.0057	.0057	.0075	.0079	.0096	.0004	.0014	.0012	.0024	.0024	.0035	.0041	.0053	.0053	.0063	.0079	.0091
140	160	.0008	.0028	.0028	.0047	.0045	.0065	.0065	.0085	.0089	.0108	.0004	.0014	.0014	.0026	.0026	.0039	.0045	.0059	.0059	.0071	.0089	.0102
160	180	.0010	.0030	.0030	.0049	.0047	.0067	.0067	.0087	.0098	.0118	.0004	.0016	.0014	.0030	.0030	.0043	.0049	.0065	.0065	.0079	.0098	.0112
180	200	.0014	.0035	.0035	.0057	.0055	.0077	.0077	.0098	.0108	.0130	.0006	.0018	.0016	.0031	.0031	.0047	.0055	.0071	.0071	.0087	.0108	.0124
200	225	.0018	.0041	.0041	.0065	.0063	.0087	.0087	.0110	.0120	.0144	.0006	.0020	.0018	.0035	.0035	.0053	.0061	.0079	.0079	.0094	.0120	.0138
225	250	.0018	.0043	.0043	.0069	.0067	.0093	.0093	.0118	.0130	.0156	.0006	.0020	.0020	.0039	.0039	.0059	.0067	.0085	.0085	.0104	.0130	.0150
250	280	.0022	.0049	.0049	.0077	.0075	.0102	.0102	.0130	.0146	.0173	.0008	.0022	.0022	.0043	.0043	.0065	.0073	.0094	.0094	.0116	.0146	.0165
280	315	.0022	.0051	.0051	.0081	.0079	.0108	.0108	.0138	.0161	.0191	.0008	.0024	.0024	.0047	.0047	.0071	.0081	.0104	.0104	.0128	.0161	.0185
315	355	.0026	.0057	.0057	.0089	.0089	.0120	.0120	.0152	.0179	.0211	.0008	.0026	.0026	.0053	.0053	.0079	.0089	.0116	.0116	.0142	.0179	.0205
355	400	.0039	.0075	.0075	.0110	.0110	.0146	.0146	.0181	.0201	.0236	.0010	.0030	.0030	.0059	.0059	.0089	.0100	.0130	.0130	.0159	.0201	.0230
400	450	.0043	.0083	.0083	.0122	.0122	.0161	.0161	.0201	.0222	.0262	.0010	.0033	.0033	.0067	.0067	.0100	.0112	.0146	.0146	.0179	.0222	.0256
450	500	.0043	.0087	.0087	.0130	.0130	.0173	.0173	.0217	.0246	.0289	.0010	.0037	.0037	.0075	.0075	.0112	.0124	.0161	.0161	.0199	.0246	.0283

Note: (1) CC is the symbol for normal clearance for matched cylindrical roller bearings and solid-type needle roller bearings.

Table 10.38 — Radial Internal Clearances in Cylindrical Roller Bearings with Tapered Bores

Units: μm

Nominal Bore Dia. $d(\text{mm})$		Clearances in Matched Bearings with Tapered Bores													
		CC9(1)		CC1		CC2		CC(2)		CC3		CC4		CC5	
over	incl	min	max	min	max	min	max	min	max	min	max	min	max	min	max
10	24	.0002	.0004	.0004	.0008	.0008	.0012	.0014	.0018	.0018	.0022	.0022	.0026	.0030	.0033
24	30	.0002	.0004	.0004	.0010	.0010	.0014	.0016	.0020	.0020	.0024	.0024	.0028	.0031	.0037
30	40	.0002	.0005	.0005	.0010	.0010	.0016	.0018	.0022	.0022	.0028	.0028	.0031	.0037	.0043
40	50	.0002	.0006	.0006	.0012	.0012	.0018	.0020	.0026	.0026	.0031	.0031	.0037	.0043	.0049
50	65	.0002	.0006	.0006	.0014	.0014	.0020	.0022	.0030	.0030	.0035	.0035	.0043	.0051	.0059
65	80	.0004	.0008	.0008	.0016	.0016	.0024	.0028	.0035	.0035	.0043	.0043	.0051	.0059	.0067
80	100	.0004	.0010	.0010	.0018	.0018	.0028	.0031	.0041	.0041	.0049	.0049	.0059	.0071	.0081
100	120	.0004	.0010	.0010	.0020	.0020	.0031	.0037	.0047	.0047	.0057	.0057	.0067	.0081	.0091
120	140	.0006	.0012	.0012	.0024	.0024	.0035	.0041	.0053	.0053	.0063	.0063	.0075	.0091	.0102
140	160	.0006	.0014	.0014	.0026	.0026	.0039	.0045	.0059	.0059	.0071	.0071	.0085	.0102	.0116
160	180	.0006	.0014	.0014	.0030	.0030	.0043	.0049	.0065	.0065	.0079	.0079	.0094	.0112	.0126
180	200	.0008	.0016	.0016	.0031	.0031	.0047	.0055	.0071	.0071	.0087	.0087	.0102	.0124	.0140
200	225	.0008	.0018	.0018	.0035	.0035	.0053	.0061	.0079	.0079	.0094	.0094	.0112	.0138	.0156
225	250	.0010	.0020	.0020	.0039	.0039	.0059	.0067	.0085	.0085	.0104	.0104	.0124	.0150	.0169
250	280	.0010	.0022	.0022	.0043	.0043	.0065	.0073	.0094	.0094	.0116	.0116	.0138	.0165	.0187
280	315	.0012	.0024	.0024	.0047	.0047	.0071	.0081	.0104	.0104	.0128	.0128	.0152	.0185	.0209
315	355	.0012	.0026	.0026	.0053	.0053	.0079	.0089	.0116	.0116	.0142	.0142	.0169	.0205	.0230
355	400	.0014	.0030	.0030	.0059	.0059	.0089	.0100	.0130	.0130	.0159	.0159	.0189	.0230	.0260
400	450	.0016	.0033	.0033	.0067	.0067	.0100	.0112	.0146	.0146	.0179	.0179	.0213	.0256	.0289
450	500	.0018	.0037	.0037	.0075	.0075	.0112	.0124	.0161	.0161	.0199	.0199	.0236	.0283	.0321

Notes (1) Clearance CC9 is applicable to cylindrical roller bearings with tapered bores in ISO Tolerance Classes 5 and 4.
 (2) CC is the symbol for normal clearance for matched cylindrical roller bearings and solid-type needle roller bearings.

Introduction

Ball Bearings

Cylindrical Roller Bearings

Spherical Roller Bearings

Tapered Roller Bearings

Thrust Bearings

Split Pillow Blocks

Super Precision Bearings

Linear Motion

Rolling Mill Bearings

Engineering Section

331

Table 10.39 — Radial Internal Clearances in Spherical Roller Bearings with Cylindrical Bores

Units: inch

Nominal Bore Diameter d (mm)		Radial Internal Clearance							
		C2		C0		C3		C4	
over	incl	low	high	low	high	low	high	low	high
24	30	+0.006	+0.010	+0.010	+0.016	+0.016	+0.022	+0.022	+0.030
30	40	+0.006	+0.012	+0.012	+0.018	+0.018	+0.024	+0.024	+0.031
40	50	+0.008	+0.014	+0.014	+0.022	+0.022	+0.030	+0.030	+0.039
50	65	+0.008	+0.016	+0.016	+0.026	+0.026	+0.035	+0.035	+0.047
65	80	+0.012	+0.020	+0.020	+0.031	+0.031	+0.043	+0.043	+0.057
80	100	+0.014	+0.024	+0.024	+0.039	+0.039	+0.053	+0.053	+0.071
100	120	+0.016	+0.030	+0.030	+0.047	+0.047	+0.063	+0.063	+0.083
120	140	+0.020	+0.037	+0.037	+0.057	+0.057	+0.075	+0.075	+0.094
140	160	+0.024	+0.043	+0.043	+0.067	+0.067	+0.087	+0.087	+0.110
160	180	+0.026	+0.047	+0.047	+0.071	+0.071	+0.094	+0.094	+0.122
180	200	+0.028	+0.051	+0.051	+0.079	+0.079	+0.102	+0.102	+0.134
200	225	+0.031	+0.055	+0.055	+0.087	+0.087	+0.114	+0.114	+0.150
225	250	+0.035	+0.059	+0.059	+0.094	+0.094	+0.126	+0.126	+0.165
250	280	+0.039	+0.067	+0.067	+0.102	+0.102	+0.138	+0.138	+0.181
280	315	+0.043	+0.075	+0.075	+0.110	+0.110	+0.146	+0.146	+0.197
315	355	+0.047	+0.079	+0.079	+0.122	+0.122	+0.161	+0.161	+0.217
355	400	+0.051	+0.087	+0.087	+0.134	+0.134	+0.177	+0.177	+0.236
400	450	+0.055	+0.094	+0.094	+0.146	+0.146	+0.197	+0.197	+0.260
450	500	+0.055	+0.102	+0.102	+0.161	+0.161	+0.217	+0.217	+0.283
500	560	+0.059	+0.110	+0.110	+0.173	+0.173	+0.236	+0.236	+0.307
560	630	+0.067	+0.122	+0.122	+0.189	+0.189	+0.256	+0.256	+0.335
630	710	+0.075	+0.138	+0.138	+0.209	+0.209	+0.276	+0.276	+0.362
710	800	+0.083	+0.154	+0.154	+0.228	+0.228	+0.303	+0.303	+0.398
800	900	+0.091	+0.169	+0.169	+0.256	+0.256	+0.339	+0.339	+0.441
900	1000	+0.102	+0.189	+0.189	+0.280	+0.280	+0.366	+0.366	+0.480

Introduction
Ball Bearings
Cylindrical Roller Bearings
Spherical Roller Bearings
Tapered Roller Bearings
Thrust Bearings
Split Pillow Blocks
Super Precision Bearings
Linear Motion
Rolling Mill Bearings
Engineering Section

Table 10.41 — Radial Internal Clearances in Spherical Roller Bearings with Tapered Bores

Units: inch

Nominal Bore Diameter d (mm)		Radial Internal Clearance							
		C2		C0		C3		C4	
over	incl	low	high	low	high	low	high	low	high
24	30	+0.008	+0.012	+0.012	+0.016	+0.016	+0.022	+0.022	+0.030
30	40	+0.010	+0.014	+0.014	+0.020	+0.020	+0.026	+0.026	+0.033
40	50	+0.012	+0.018	+0.018	+0.024	+0.024	+0.031	+0.031	+0.039
50	65	+0.016	+0.022	+0.022	+0.030	+0.030	+0.037	+0.037	+0.047
65	80	+0.020	+0.028	+0.028	+0.037	+0.037	+0.047	+0.047	+0.059
80	100	+0.022	+0.031	+0.031	+0.043	+0.043	+0.055	+0.055	+0.071
100	120	+0.026	+0.039	+0.039	+0.053	+0.053	+0.067	+0.067	+0.087
120	140	+0.031	+0.047	+0.047	+0.063	+0.063	+0.079	+0.079	+0.102
140	160	+0.035	+0.051	+0.051	+0.071	+0.071	+0.091	+0.091	+0.118
160	180	+0.039	+0.055	+0.055	+0.079	+0.079	+0.102	+0.102	+0.134
180	200	+0.043	+0.063	+0.063	+0.087	+0.087	+0.114	+0.114	+0.146
200	225	+0.047	+0.071	+0.071	+0.098	+0.098	+0.126	+0.126	+0.161
225	250	+0.055	+0.079	+0.079	+0.106	+0.106	+0.138	+0.138	+0.177
250	280	+0.059	+0.087	+0.087	+0.118	+0.118	+0.154	+0.154	+0.193
280	315	+0.067	+0.094	+0.094	+0.130	+0.130	+0.169	+0.169	+0.213
315	355	+0.075	+0.106	+0.106	+0.142	+0.142	+0.185	+0.185	+0.232
355	400	+0.083	+0.118	+0.118	+0.157	+0.157	+0.205	+0.205	+0.256
400	450	+0.091	+0.130	+0.130	+0.173	+0.173	+0.224	+0.224	+0.283
450	500	+0.102	+0.146	+0.146	+0.193	+0.193	+0.248	+0.248	+0.311
500	560	+0.114	+0.161	+0.161	+0.213	+0.213	+0.268	+0.268	+0.343
560	630	+0.126	+0.181	+0.181	+0.236	+0.236	+0.299	+0.299	+0.386
630	710	+0.138	+0.201	+0.201	+0.264	+0.264	+0.335	+0.335	+0.429
710	800	+0.154	+0.224	+0.224	+0.295	+0.295	+0.378	+0.378	+0.480
800	900	+0.173	+0.252	+0.252	+0.331	+0.331	+0.421	+0.421	+0.539
900	1000	+0.193	+0.280	+0.280	+0.366	+0.366	+0.469	+0.469	+0.598

SELECTION OF BEARING INTERNAL CLEARANCE

By way of definition, "Normal Operating Conditions" for bearings occur when the bearing load does not exceed the equivalent load ($P=0.1C$), the inner ring is tight-fitted to the shaft and operating speed is less than 50% of the limiting speed given in the bearing tables. For the replacement market the standard clearance group, **C3**, is used for "Normal Operating Conditions." However, there are six standard clearance groups, designated as **C1**, **C2**, **C0**, **C3**, **C4** and **C5**. **C1** represents minimum clearance and **C5** represents maximum clearance.

Selection of the proper bearing clearance varies with required fits, loads, speeds, and operating temperatures. Each of these will reduce the initial internal clearance a certain amount. Changes that occur in the radial clearance of roller bearings are shown in Figure 10.42.

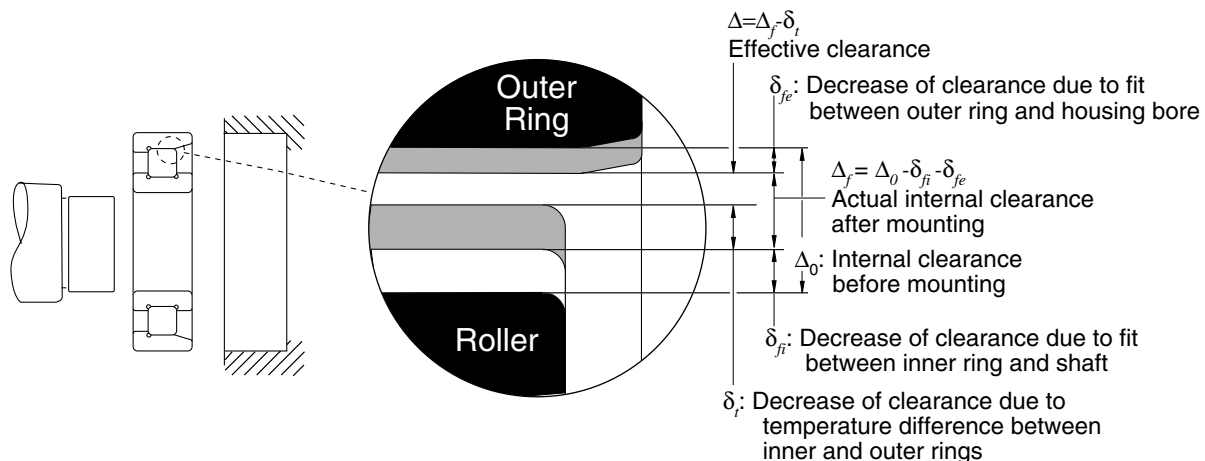

FIGURE 10.42 — CHANGES OF RADIAL INTERNAL CLEARANCE OF BEARING

CHANGES IN RADIAL INTERNAL CLEARANCE

Decrease in Radial Clearance Due to Fit

When the inner or outer ring is tight-fitted to the shaft or the housing, a decrease of radial internal clearance is caused by the expansion or contraction of the bearing rings. The decrease varies according to the bearing type, bearing size and shape, and design of the shaft or housing. The amount of decrease normally ranges from 70 to 90% of the interference.

The internal clearance after mounting is obtained by subtracting the interference decrease, Δf , from the initial internal clearance.

Temperature Effects on Radial Internal Clearance

Under normal operation, the radial internal clearance of a bearing will decrease because of the temperature differences between the inner and outer rings. Typically, the temperatures of the inner ring and the rolling elements are higher than that of the outer ring by 8 to 15°F. When the shaft is heated or when the housing is cooled, the difference between the inner and outer rings is even larger.

The amount of decrease due to thermal expansion can be calculated from the following equations:

$$\delta_t = \alpha \Delta_t D_e$$

Where δ_t : Internal clearance decrease (inch) due to temperature

α : Coefficient of linear expansion of bearing steel (12.5×10^{-6}) ($1/^\circ\text{C}$)

Δ_t : Temperature difference between inner & outer rings ($^\circ\text{C}$)

D_e : Outer ring raceway diameter (inch)

For Ball Bearings: $D_e = \frac{1}{5}(4D + d)$

For Roller Bearings: $D_e = \frac{1}{4}(3D + d)$

Where **D**: Bearing outside diameter (inch)

d: Bearing bore diameter (inch)

Effective Clearance

The effective, or operating, clearance Δ is obtained by subtracting δ_t from the internal clearance after mounting Δ_f . Theoretically, the longest life of a bearing can be expected when the effective clearance is slightly negative. However, it is difficult to achieve this condition and excessive negative clearance will shorten bearing life. Therefore, a clearance of zero or a slightly positive value is preferable.

Angular contact ball bearings or tapered roller bearings normally require the user to set the internal clearance at mounting. The user should check the proper orientation of these bearings by checking the original bearings or the service manual for the machine. A check should also be made for the recommended set clearance. This can be obtained from the service manual, the machine manufacturer, or the bearing manufacturer.

Preloaded Bearings

Types and Features

Rolling bearings usually retain some internal clearance while in operation. However, in some cases it is desirable to provide a negative clearance. This is called "preloading." Preloading can be used to decrease bearing deflection and provide greater bearing rigidity. However, it may also increase power consumption and reduce bearing life.

A preload is usually given to those types of bearings in which the axial clearance can be adjusted in mounting--for example, angular contact ball bearings and tapered roller bearings. Usually preloaded bearings are mounted face to face or back to back to form a duplex bearing set.

WHY PRELOAD?

Typical reasons and applications for preloading bearings are:

- To maintain bearings in an exact position in both the radial and axial directions and to maintain the running accuracy of the shaft... for example, the main shaft of machine tools and instruments.
- To increase bearing rigidity. This is often needed on the main shaft of machine tools or the pinion shaft of automobile differentials.
- To minimize noise due to axial vibration and resonance... for example, in high speed or high acceleration applications of angular contact ball bearings and thrust ball bearings
- To prevent sliding due to the gyratory movement of rolling elements... for example, in high speed or high acceleration applications of angular contact ball bearings and thrust ball bearings.
- To maintain the rolling elements in their proper position with the bearing rings... for example, on thrust ball bearings and spherical roller thrust bearings mounted on a horizontal shaft.

HOW TO PRELOAD DUPLEX BEARINGS

There are two basic methods for preloading duplex bearings--preloading by position and preloading by constant pressure:

Position Preload

Position preload is achieved by positioning two axially opposed bearings while maintaining their relative positions in operation. This is usually done by one of the following methods:

- Installing a duplex bearing set with previously adjusted stand-out dimensions and axial clearance.
- Using a spacer or shim with proper dimensions to obtain the required spacing and preload. See Figure 10.43.
- Using bolts or nuts to allow adjustment of the axial clearance. In this case the starting friction torque should be measured to verify the proper preload.

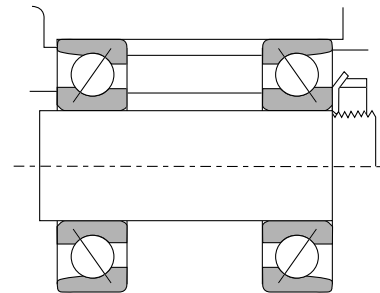

Figure 10.43 — Example of Position Preload

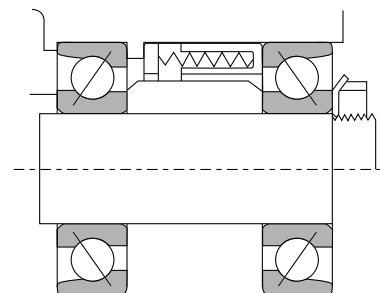

Figure 10.44 — Example of Constant Pressure Preload

Constant Pressure Preload

Constant pressure preload is achieved by using a coil or leaf spring to impose a constant preload. Even if the relative position of the bearings changes during operation, the magnitude of the preload remains relatively constant. See Figure 10.44

SELECTING PRELOADING METHOD AND THE AMOUNT OF PRELOAD TO USE

Comparison of Preloading Methods

A comparison of rigidity using different preloading methods is shown in the chart below.

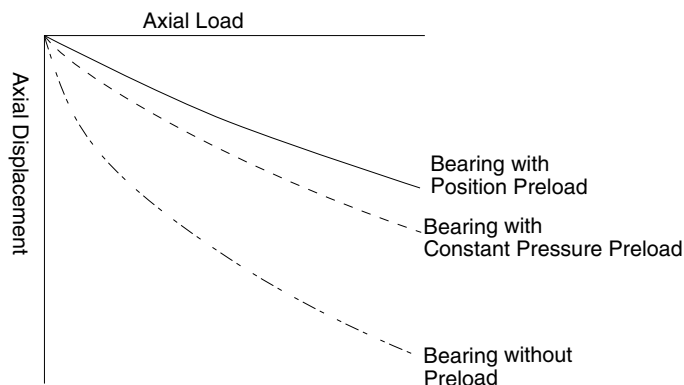

Figure 10.45 — Preload and Rigidity

Position preloading is generally preferred for increasing rigidity. Constant pressure preload is more suitable for high speed applications, prevention of axial vibration, and for use with thrust bearings on horizontal shafts. Position preload and constant pressure preload each offer specific advantages:

- When equal preloads are imposed, the position preload provides greater bearing rigidity. The deflection due to external loads is less for bearings with a position preload.
- In position preloading the level of preload varies depending on such factors as a difference in axial expansion due to a temperature difference between the inner and outer rings and deflection due to load.
- In constant pressure preloading it is possible to minimize any change in the preload because the variation of the spring load with shaft expansion and contraction is negligible.

How Much Preload to Use?

If the preload is larger than necessary, abnormal heat generation, increased frictional torque and reduced fatigue life may occur. The amount of the preload should be determined considering the operating conditions, the purpose of the preload, and the type of bearing to be preloaded.

Preload of Duplex Angular Contact Ball Bearings — The average preloads for duplex angular contact ball bearings (contact angle of 15°) with precision better than P5 class are listed in the tables on the following page. These bearings are used on the main shafts of machine tools.

The recommended fits between the shaft and inner ring, and between the housing and outer ring are listed in Table 10.31 on page 328 thru Table 10.34 on page 329.

For housing fits, the lower limit of the fit range should be selected for fixed-end bearings and the upper limit for free-end bearings.

As a general rule, an extra light or light preload should be selected for spindles of grinders and a medium preload should be selected for the main shafts of high speed lathes and milling machines.

Figure 10.46 — Preload for Duplex Angular Contact Ball Bearings (Series 7000)

Units: Lbf

Bearing Number	Preload			
	Very Light C2	Light C7	Medium C8	Heavy C9
7000C	1.21	6.38	13.26	28.55
7001C	1.33	7.08	14.28	30.80
7002C	1.43	7.76	16.52	35.30
7003C	1.54	8.43	17.65	37.54
7004C	2.86	15.40	30.80	66.09
7005C	3.08	16.52	33.05	73.06
7006C	4.18	22.03	46.31	96.67
7007C	5.51	28.55	61.82	132.64
7008C	6.38	33.05	68.57	142.75
7009C	7.76	42.26	84.30	176.48
7010C	8.54	44.06	92.17	198.96
7011C	11.02	59.57	121.40	265.28
7012C	12.14	61.82	132.64	276.52
7013C	13.26	68.57	142.75	307.99
7014C	16.52	87.68	187.72	386.67
7015C	17.65	92.17	187.72	406.91
7016C	20.91	110.16	231.55	508.07
7017C	22.03	121.40	242.79	528.30
7018C	26.53	142.75	296.75	618.23
7019C	28.55	142.75	307.99	660.94
7020C	28.55	153.99	319.23	685.67

Figure 10.47 — Preload for Duplex Angular Contact Ball Bearings (Series 7200)

Units: Lbf

Bearing Number	Preload			
	X-tra Light C2	Light C7	Medium C8	Heavy C9
7200C	1.21	6.38	13.26	28.55
7201C	1.88	9.89	20.91	44.06
7202C	2.09	11.02	22.03	48.56
7203C	2.65	14.28	28.55	61.82
7204C	3.75	19.90	39.79	85.43
7205C	4.41	24.28	48.56	103.41
7206C	6.61	33.05	70.82	153.99
7207C	8.77	46.31	94.42	198.96
7208C	11.02	57.33	121.40	254.04
7209C	12.14	63.85	132.64	285.51
7210C	13.26	70.82	142.75	307.99
7211C	16.52	87.68	187.72	397.91
7212C	20.91	110.16	231.55	485.59
7213C	24.28	132.64	265.28	573.27
7214C	26.53	142.75	296.75	618.23
7215C	28.55	153.99	319.23	660.94
7216C	33.05	165.24	352.95	753.11
7217C	37.54	198.96	406.91	876.76
7218C	44.06	231.55	485.59	1011.65
7219C	46.31	242.79	508.07	1079.09
7220C	52.83	276.52	573.27	1236.46

Figure 10.49 — Recommended Fits for Precision Class Duplex Angular Contact Ball Bearings with Preload

Nominal Bore Dia. (mm)		Target Shaft Interference (inch)	Nominal Outside Dia. (mm)		Target Housing Clearance (inch)	
Over	Incl.		Over	Incl.		
–	18	0 – 0.0001	–	18	–	–
18	30	0 – 0.0001	18	30	+0.0001	+0.0002
30	50	0 – 0.0001	30	50	+0.0001	+0.0002
50	80	0 – 0.0001	50	80	+0.0001	+0.0003
80	120	0 – 0.0002	80	120	+0.0001	+0.0004
120	150	–	120	150	+0.0002	+0.0005
150	180	–	150	180	+0.0002	+0.0005
180	250	–	180	250	+0.0002	+0.0006

Preload of Thrust Ball Bearings

When the balls in thrust ball bearings rotate at relatively high speeds, sliding due to the gyratory movement of the balls may occur. The larger of the two values obtained from the equations below should be selected as the minimum axial load in order to prevent such sliding.

$$F_{a,min} = \frac{C_{oa}}{100} \left(\frac{n}{N_{max}} \right)^2$$

Where $F_{a,min}$: Minimum axial load, N
 C_{oa} : Basic static load rating, N
 n : Rotational speed, rpm
 N_{max} : Limiting speed (oil lubrication), rpm

Preload of Spherical Roller Thrust Bearings

When spherical roller thrust bearings are used a preload is necessary to keep the rollers in proper position against the outer ring raceway. The minimum axial load $F_{a,min}$ necessary to do this is:

$$F_{a,min} = \left(\frac{C_{oa}}{1000} \right)$$

Introduction
Ball Bearings
Cylindrical Roller Bearings
Spherical Roller Bearings
Tapered Roller Bearings
Thrust Bearings
Split Pillow Blocks
Super Precision Bearings
Linear Motion
Rolling Mill Bearings
Engineering Section

Bearing Lubrication

LUBRICATION--THE PURPOSE

Lubrication is needed to reduce friction and wear inside the bearing. Proper lubrication and procedures will allow the bearing to reach its expected life.

Primarily, lubrication serves the following purposes:

- Reduces Friction and Wear – Direct metallic contact between the bearing rings, rolling elements and cage is prevented by an oil film which reduces the friction and heat at the contact areas.
- Extends Bearing Life – The rolling fatigue life of bearings depends in a large part on the viscosity and film thickness of the lubricant. A heavy film thickness prolongs the bearing fatigue life.
- Cooling – Circulating oil can be used to carry heat away from the bearing. A circulating system is normally used when excessive heat is generated by the bearing due to high speeds, high loads, or when heat from a source adjacent to the bearing can affect its operation. Oils deteriorate at high temperatures; therefore it is important to keep both the oil and the bearing cool.
- Other Purposes – Proper lubrication also helps to prevent foreign material from entering the bearings, and protects against corrosion or rusting.

SELECTING THE CORRECT LUBRICATION METHOD

Lubrication can be accomplished by using either oil or grease. The most satisfactory bearing performance will be achieved by selecting the method most suitable for a specific application. This of course will also depend on the conditions under which the bearing will operate.

Oil lubrication is superior in lubricating efficiency, however, grease lubrication allows a simpler structure around the bearings. The following table compares oil and grease lubrication.

Operating Factor	Grease Lubrication	Oil Lubrication
Housing Structure and Sealing Method	Simple	May be complex. Careful maintenance required.
Speed	Limiting speed is 65% to 80% of that of oil lubrication	High limiting speed
Cooling Effect	Poor	Heat transfer is possible using forced oil circulating lubrication
Fluidity	Poor	Good
Full Lubricant Replacement	Sometimes difficult	Easy
Removal of Foreign Matter	Removal of particles from grease is impossible	Easy
External Contamination Due to Leakage	Surroundings seldom contaminated by leakage	Often leaks without proper countermeasures. Not suitable if external contamination must be avoided

GREASE LUBRICATION

Grease Quantity

The quantity of grease to be packed in a housing depends on the housing design, rotational speeds of the bearings, characteristics of the grease selected, and the ambient temperature conditions. These factors are critical to satisfactory performance.

Introduction

Ball Bearings

Cylindrical Roller Bearings

Spherical Roller Bearings

Tapered Roller Bearings

Thrust Bearings

Split Pillow Blocks

Super Precision Bearings

Linear Motion

Rolling Mill Bearings

Engineering Section

In applications where the operating speed does not exceed one-half the rated limiting speed of the bearing, the bearing should be packed one-half to two-thirds full. If the speed of the bearing exceeds one-half the limiting speed, the quantity of grease should be reduced to one-third to one-half full and periodic regreasing scheduled. When operating conditions are not severe, the original pack of grease should last a long time without replenishment. If the operating conditions become severe, it will be necessary to regrease periodically.

Care should be taken to avoid excessive greasing as this will cause bearings to overheat.

GREASE REPLENISHMENT

Frequent grease replenishment is required when operating conditions are severe such as in high ambient temperatures or where contaminants can enter bearing housings. Routine regreasing schedules should be established. In cases where extremely severe conditions exist or the bearings are in a remote area, the bearing housing should be designed to make replenishment and replacement as simple as possible. Automatic grease systems are available and should be used.

For normal operating conditions, it may be necessary to regrease the bearing periodically to replace any grease which has leaked from the housing and to eliminate any deteriorated grease.

OIL LUBRICATION

When the operating speed exceeds the grease limiting speed listed for the bearing, oil lubrication should be used. Several methods are available and are described below. The best method to use will depend on operating conditions.

OIL BATH LUBRICATION is a common method used where bearings are operating below the listed oil limiting speed. The static oil level should be set at the center of the lowest rolling element. An oil sight level gauge should be included in the system so that proper oil level can be quickly monitored.

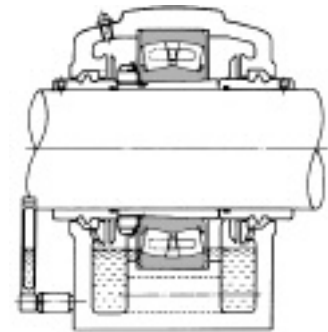

DRIP FEED LUBRICATION is often used for small bearings operated at relatively high speeds. In the illustration, a visible oiler is used. The oil drip rate is controlled by a screw valve located at the top of the oil cup.

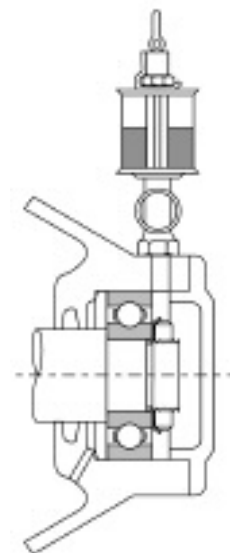

Introduction
Ball Bearings
Cylindrical Roller Bearings
Spherical Roller Bearings
Tapered Roller Bearings
Thrust Bearings
Split Pillow Blocks
Super-Precision Bearings
Linear Motion
Rolling Mill Bearings
Engineering Section

Splash Lubrication – In this lubricating method, oil is splashed onto the bearings by gears or by a simple rotating disc. This method is commonly used in automobile transmissions, differentials and gear boxes. The illustration shows splash lubrication used on a reduction gear.

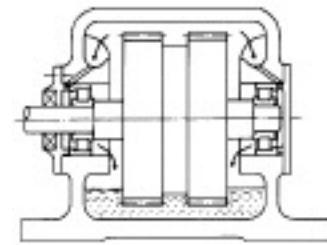

Circulating system lubrication is commonly used for high speed operation and for bearings used at high temperatures. As shown in the illustration, oil from the supply pipe circulates through the bearings and exits to an external reservoir. After cooling in the reservoir it returns to the bearing through a pump and filter. In a circulating system, the oil outlet should be larger in diameter than the supply pipe so that an excessive amount of oil will not remain in the housing.

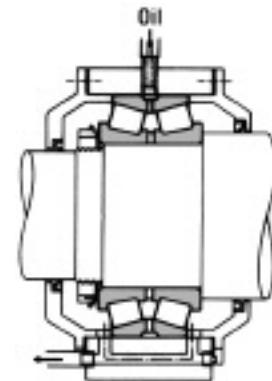
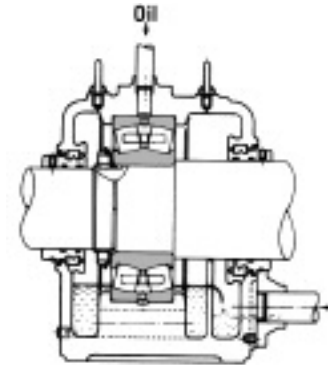

Jet Lubrication is often used for ultra high speed bearings, such as the bearings in jet engines and in machine tool spindles. In this method, lubricating oil is sprayed under pressure from one or more nozzles directly into the rolling elements of the bearing. The illustration shows an example of typical jet lubrication.

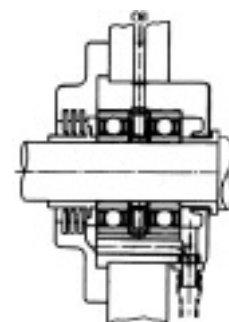
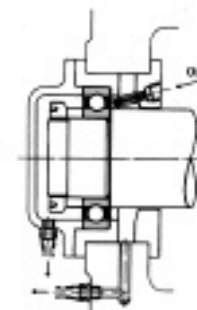

Oil Mist Lubrication, – also called oil fog lubrication, uses air to atomize the oil and carry it into the bearing. This method is used in bearings for the ultra high-speed spindles of machine tools, high-speed rotary pumps, and roll necks of rolling mills, as shown in the illustration.

In **Oil/Air Lubrication** systems, a small quantity of oil is periodically injected into an air stream which carries it to the bearing. This system is used when it is necessary to precisely control the quantity of oil entering the bearing to control operating temperature.

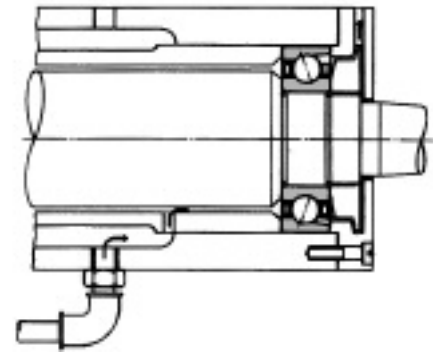

Introduction
Ball Bearings
Cylindrical Roller Bearings
Spherical Roller Bearings
Tapered Roller Bearings
Thrust Bearings
Split Pillow Blocks
Super Precision Bearings
Linear Motion
Rolling Mill Bearings

Lubricants

LUBRICATING GREASE

Grease is a semi-solid lubricant of a base oil and a thickener. Other ingredients are sometimes added to impart special properties to the base.

The main types and general properties of grease are shown in Table 10.50 on page 343. It should be noted that different brands of the same type of grease may have different properties.

Base Oil – Mineral oil or synthetic oils such as silicon or diester oil, are commonly used as the base oil for grease. The lubricating properties of grease are dependent on the characteristics of its base oil. The viscosity of the base oil is an important consideration when selecting grease. Usually grease made with a low viscosity base oil is more suitable for high speeds and low temperatures while grease made with high viscosity base oils is more suited for high temperatures and heavy loads. The thickener also influences the lubricating properties of grease, therefore selection criteria for grease are not the same as for lubricating oil.

Thickener – Several types of metallic soaps, inorganic compounds such as silica gel and bentonite, and heat resisting organic thickeners such as polyurea and flouric compounds are used as thickeners for grease. The water resistance properties of grease depend on the type of thickener. Sodium soap grease (or compound grease containing sodium soap) emulsifies when exposed to water or high humidity and therefore cannot be used where moisture is prevalent. Lithium soap grease, on the other hand, is recommended where moisture is present because of its resistance to wash off.

For applications where the operating temperature exceeds the limitation of common multi-purpose grease, greases having complex bases or non-soap bases are recommended. The grease used should also have a synthetic oil to withstand rapid deterioration at high temperatures. If the grease used in a high temperature application uses a mineral oil, it should be replenished frequently as deterioration of the oil will be accelerated at high temperatures.

Additives – Grease often contains a variety of additives such as antioxidants, corrosion inhibitors, and extreme pressure additives to give it special properties. Extreme pressure additives are recommended for use in heavy load applications. For long use without replenishment, an antioxidant should be added.

Consistency – Consistency indicates the “softness” of the grease. The following table shows the relationship between consistency and working conditions.

		Consistency Number (Given by the National Lubricating Grease Institute (NLGI) Scale)				
		0	1	2	3	4
Consistency ¹⁾ (1/10 mm)		385~355	340~310	295~265	250~220	205~175
Working Condition		For centralized oiling. When false brinelling is liable to occur.	For centralized oiling. When fretting is liable to occur. For low temperature.	For general use. For sealed bearings.	For high temperature. For general use. For sealed bearings	For high temperature. For grease seals

1) Consistency: Depth into grease attained by a cone when pressed with a specified weight, indicated in units of 1/10 mm. The larger the value, the softer the grease.

Mixing Different Types of Grease – In general, grease of different types must not be mixed. Mixing grease with different types of thickeners may destroy the composition and physical properties of the grease. Even if the thickeners are of the same type, possible differences in the additives may cause detrimental effects.

Introduction

Ball Bearings

Cylindrical Roller Bearings

Spherical Roller Bearings

Tapered Roller Bearings

Thrust Bearings

Split Pillow Blocks

Super Precision Bearings

Linear Motion

Rolling Mill Bearings

Engineering Section

Figure 10.50 — Grease Properties

Popular Name →	Lithium Grease			Sodium Grease (Fiber Grease)	Calcium Grease (Cup Grease)	Mixed Base Grease	Complex Grease	Non-Soap Base Grease	
	Li Soap			Na Soap	Ca Soap	Na+Ca Soap, Li +Ca Soap, etc.	Ca Complex, A1 Complex, etc.	Silica Gel, Bentonite, Carbon Black, Polyurea, Flouric Compounds, Heat Resistant Organic Compound, etc.	
	Mineral Oil	Diester Oil	Silicone Oil	Mineral Oil	Mineral Oil	Mineral Oil	Mineral Oil	Mineral Oil	Synthetic Oil
Dropping Point, C°	170~190	170~195	200~210	170~210	70~90	160~190	180~300	230	240~
Working Temp., C°	-20~110	-50~130	-50 ~160	-20~130	-20 ~60	-20~80	-20 ~130	-10 ~130	~250
Working Speed, % ⁽²⁾	70	100	60	70	40	70	70	70	40~100
Mechanical Stability	Good	Good	Good	Good	Poor	Good	Good	Good	Good
Pressure Resistance	Fair	Fair	Poor	Fair	Poor	Fair to Good	Fair to Good	Fair	Fair
Water Resistance	Good	Good	Good	Poor	Good	Poor for Na Soap Grease	Good	Good	Good
Rust Prevention	Good	Good	Poor	Poor to Good	Good	Fair to Good	Fair to Good	Fair to Good	Fair to Good
Remarks	General purpose lubricant.	Good low temperature and torque characteristics. Often used for small motor and instrument bearings	Mainly for high temperature applications. Unsuitable for bearings under high speed or heavy load conditions or for sliding contact areas (roller bearings)	Long and short fiber types available. Long fiber grease is not suitable for high speeds or for sliding contact areas (roller bearings)	Not suitable for high temp. and heavy loads. Extreme pressure grease containing high viscosity oil and extreme pressure additive (Pb soap, etc.) is available	Often used for roller bearings and large ball bearings	Suitable for extreme pressures. Mechanically stable.	Medium and high temperature lubricant	Recommended for special environments with very high and low temperatures, acids, alkalis, radioactivity, and exposure to flames.

(1) The grease properties shown here can vary between different brands.
 (2) The values listed are percentages of the limiting speeds given in the bearing tables.

Lubricating Oil

Lubricating oil used for bearings is usually a highly refined mineral or synthetic oil which has a high film strength and superior oxidation and corrosion resistance. When selecting an oil, the viscosity of the operating conditions is very important. If the viscosity is too low, a proper oil film is not formed and abnormal wear and seizure may occur. On the other hand, if the viscosity is too high, excessive viscous resistance may cause heating or a large power loss. In general, low viscosity oils should be used at high speeds. Higher viscosity oils should be used for heavy loads or for the larger bearings. The following table shows the generally recommended viscosity for certain bearing types.

Bearing Types	Proper Viscosity at the Operating Temperature
Ball Bearings and Cylindrical Roller Bearings	Higher than 13 cSt
Tapered Roller Bearings and Spherical Roller Bearings	Higher than 20 cSt
Spherical Roller Thrust Bearings	Higher than 32 cSt

Introduction

Ball Bearings

Cylindrical Roller Bearings

Spherical Roller Bearings

Tapered Roller Bearings

Thrust Bearings

Split Pillow Blocks

Super Precision Bearings

Linear Motion

Rolling Mill Bearings

Engineering Section

The following chart shows the relationship between temperature and viscosity for use in selection of the proper lubricating oil.

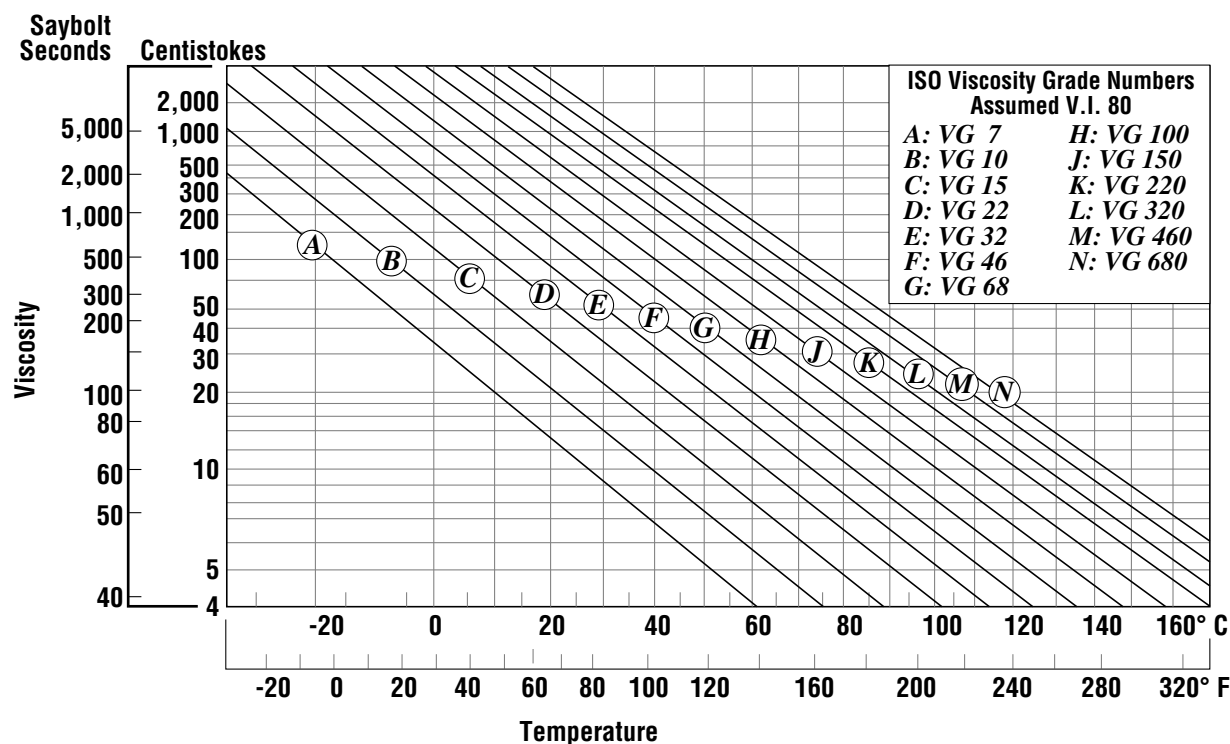

Table 10.51 – Temperature – Viscosity Chart

Oil Replacement Interval – The oil replacement interval depends on the operating conditions and oil quantity. In those cases where the operating temperature is less than 120°F and the environmental conditions are good, oil should be replaced approximately once a year. However, where the oil temperature is about 212°F the oil must be changed at least once every three months.

In dirty environmental conditions, or if moisture or foreign material is mixed in the oil, the replacement interval must be shortened.

Mixing different brands of lubricating oil should be avoided.

Introduction

Ball Bearings

Cylindrical Roller Bearings

Spherical Roller Bearings

Tapered Roller Bearings

Thrust Bearings

Split Pillow Blocks

Super Precision Bearings

Linear Motion

Rolling Mill Bearings

Engineering Section

HOW TO HANDLE BEARINGS

Rolling bearings are high precision machine parts and need to be handled carefully. When installing or removing a bearing, correct procedures should be followed. Careless handling during mounting and removal could result in a serious accident, injuring people and damaging property.

Whether installing, removing, mounting, dismounting, replacing or inspecting, a few simple precautions must be followed:

Keep Bearings and Surroundings Clean!

Dust and dirt, even if invisible to the naked eye, can harm bearings. To prevent the entry of dust and dirt, keep bearings and their environment as clean as possible. Never remove a bearing from its package until you are ready to mount it.

Handle With Care!

Heavy shocks during handling may cause bearings to be scratched or otherwise damaged. Excessively strong impacts when mounting, dismounting or handling may cause brinelling, breaking or cracking.

Use Proper Tools!

Always use the proper equipment and tools to install or remove bearings. Avoid using general purpose tools such as hammers, screwdrivers, wrenches and pliers.

Protect Bearings From Corrosion!

Keep hands clean when handling bearings. Perspiration and other contaminants on the hands can cause corrosion on the bearings. Wear gloves, if possible. Apply oil or grease to non-sealed bearings immediately after installation for further protection.

MOUNTING--FACTORS TO CONSIDER

Bearings are very precise and their mounting requires careful attention. The following items must be considered:

- Cleaning related parts
- Dimensions and finish of related parts
- Mounting procedures
- Inspection after mounting
- Supply of lubricants.

Prelubricated bearings and bearings lubricated with ordinary oil or grease should not be washed before installation. The preservative used on the bearing to protect it during storage is compatible with most common lubricants.

Bearings used for instruments or high speed applications, such as machine tool bearings, can be washed before installation to remove the anti-corrosion agent used in manufacturing. These bearings must be washed in clean, filtered oil and protected from corrosion until they are installed and lubricated.

Bearing mounting methods depend on bearing type and the type of fit. As bearings are usually used with rotating shafts, the inner rings require a tight fit. Bearings with cylindrical bores are usually

mounted by pressing through the inner ring on the shafts (press fit) or heating them to expand their diameter (shrink fit). Bearings with tapered bores can be mounted directly on tapered shafts or on cylindrical shafts by using tapered sleeves.

Bearings are usually mounted in housings with a loose fit. However, if the outer ring has an interference fit, a press may be used. Bearings can be interference fitted by cooling before mounting, using dry ice. If this is done, a rust preventive treatment must be applied to the bearings because moisture in the air will condense on bearing surfaces.

MOUNTING BEARINGS WITH CYLINDRICAL BORES

Press Fits – Fitting with a press is widely used for small bearings. Before mounting, oil should be applied to the fitted shaft surface to make insertion smoother. A mounting tool is placed on the inner ring as shown in Figure 10.52. The mounting tool must not be placed on the outer ring for press mounting, because this may damage the bearing. The bearing is slowly pressed onto the shaft until the side of the inner ring rests against the shoulder of the shaft.

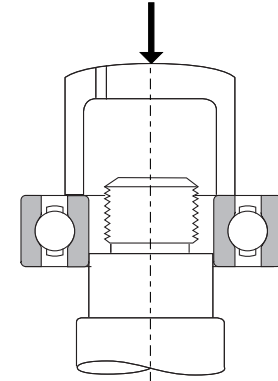

Figure 10.52 – Press Mounting of Inner Ring

Using a hammer for mounting should only be done if pressing equipment is not available. Any time a hammer is used, a mounting tool must be placed on the inner ring. For tight interference fits or for medium and large bearings, a hammer should never be used.

When both the inner and outer rings of non-separable bearings, such as deep groove ball bearings, require a tight fit, a mounting tool should be placed on both rings and both rings fitted at the same time using a screw or hydraulic press. See Figure 10.53.

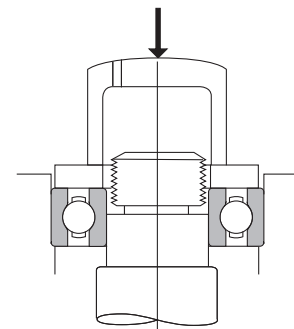

Figure 10.53 – Simultaneous Press Mounting of Inner & Outer Ring

When mounting separable bearings, such as cylindrical roller bearings and tapered roller bearings, the inner and outer rings may be mounted separately.

A mounting tool such as that shown in Figure 10.53 should also be used for mounting self-aligning bearings. Assembly of the inner and outer rings which were previously mounted separately must be done carefully to align them correctly. Careless or forced assembly may cause scratches on the rolling contact surfaces.

Shrink Fits – Shrink fitting is often used to avoid the large force involved in press fitting large bearings. This method eliminates the need to impose excessive force on the bearings. For shrink fitting, the bearings are first heated in oil, or in an induction heater, to expand them, then mounted and allowed to cool.

This amount of expansion of the inner ring for various temperature differences and bearing sizes are shown in Figure 10.54

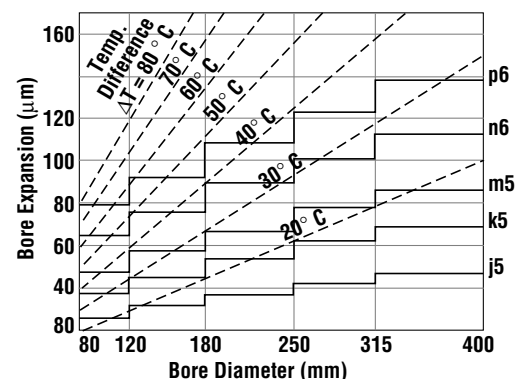

Figure 10.54 – Temperature and Expansion of Inner Ring

A few precautions to be considered when making shrink fits:

- Do not heat bearings to more than 248°F.
- Put bearings on a wire netting or suspend them in the oil tank to prevent them from touching the tank bottom.

- Heat bearings to a temperature 68 to 86°F higher than the lowest temperature required for mounting, because the inner ring will cool a little during mounting.

After mounting, the bearings will shrink in the axial direction as well as the radial direction while cooling. Therefore, while mounting, press the bearing firmly against the shaft shoulder to avoid excessive clearance between the bearing and the shoulder. Mixing different brands of lubricating oil should be avoided.

MOUNTING BEARINGS WITH TAPERED BORES

Bearings with tapered bores can be mounted on tapered shafts directly or on cylindrical shafts by using tapered adapters or withdrawal sleeves.

Large spherical bearings are often mounted using hydraulic pressure. Figure 10.55 shows two different hydraulic mounting methods. One method is a sleeve with a hydraulic nut. The other method uses a sleeve with pressurized oil. Holes drilled in the sleeve are used to feed oil under pressure to the bearing seat. As the bearing expands radially, the sleeve is inserted axially with adjusting bolts.

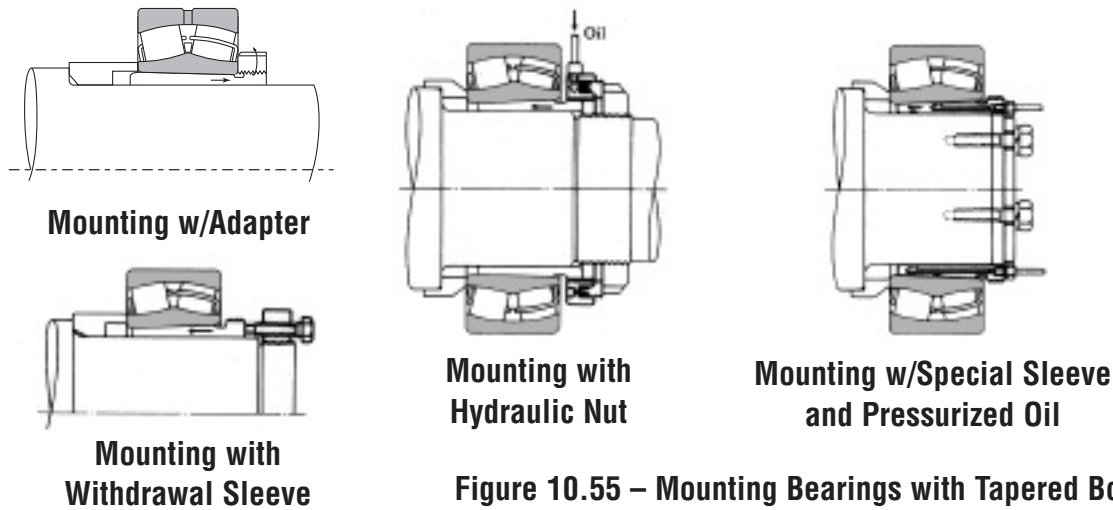

Figure 10.55 – Mounting Bearings with Tapered Bores

The internal clearance of a tapered bore bearing varies with the tightness of the interference fit. It is necessary to check the clearance often as the bearing is being mounted. The bearing should be pressed until the reduction of radial clearance is within the range shown in Table 10.56 on page 348.

Table 10.56 — Mounting of Spherical Roller Bearings with Tapered Bores

Units: Inch

Nominal Bore Diameter (mm)		Radial internal Clearance (inches)						Reduction in Radial Clearance		Axial Movement				Minimum Permissible Residual Clearance After Mounting		
		Normal		C3		C4				Taper 1:12		Taper 1:30				
over	incl.	min	max	min	max.	min.	max.	min.	max.	min.	max.	min.	max.	Normal	C3	C4
30	40	.0014	.0020	.0020	.0026	.0026	.0033	.0005	.0010	.011	.016	-	-	.0006	.0012	.0018
40	50	.0018	.0024	.0024	.0032	.0032	.0041	.0010	.0010	.014	.018	-	-	.0006	.0012	.0020
50	65	.0022	.0030	.0030	.0039	.0039	.0049	.0010	.0015	.018	.024	-	-	.0010	.0014	.0024
65	80	.0028	.0037	.0037	.0049	.0049	.0061	.0015	.0020	.024	.032	-	-	.0012	.0016	.0030
80	100	.0032	.0044	.0044	.0057	.0057	.0075	.0020	.0025	.027	.040	.070	.085	.0014	.0020	.0032
100	120	.0039	.0053	.0053	.0069	.0069	.0089	.0020	.0030	.030	.048	.075	.090	.0018	.0026	.0040
120	140	.0047	.0063	.0063	.0081	.0081	.0102	.0025	.0035	.040	.056	.090	.110	.0022	.0031	.0045
140	160	.0051	.0071	.0071	.0091	.0091	.0118	.0030	.0040	.048	.062	.100	.130	.0024	.0039	.0050
160	180	.0055	.0079	.0079	.0102	.0102	.0134	.0030	.0045	.048	.069	.110	.140	.0028	.0043	.0060
180	200	.0063	.0088	.0088	.0114	.0114	.0146	.0035	.0050	.056	.082	.130	.160	.0028	.0043	.0065
200	225	.0071	.0099	.0099	.0126	.0126	.0162	.0040	.0055	.064	.088	.140	.170	.0031	.0051	.0070
225	250	.0079	.0106	.0106	.0140	.0140	.0178	.0045	.0060	.072	.094	.160	.190	.0035	.0055	.0080
250	280	.0087	.0118	.0118	.0156	.0156	.0195	.0050	.0070	.080	.106	.170	.220	.0039	.0059	.0085
280	315	.0094	.0130	.0130	.0169	.0169	.0213	.0050	.0070	.080	.118	.190	.240	.0043	.0063	.0095
315	355	.0106	.0142	.0142	.0187	.0187	.0234	.0060	.0080	.096	.131	.220	.270	.0047	.0071	.0105
355	400	.0118	.0157	.0157	.0207	.0207	.0258	.0070	.0090	.104	.144	.240	.300	.0051	.0079	.0115
400	450	.0130	.0173	.0173	.0224	.0224	.0283	.0080	.0100	.128	.160	.270	.330	.0055	.0087	.0125
450	500	.0146	.0193	.0193	.0248	.0248	.0311	.0090	.0110	.136	.176	.300	.360	.0063	.0094	.0140
500	560	.0161	.0213	.0213	.0275	.0275	.0343	.0100	.0130	.152	.208	.340	.430	.0067	.0106	.0155
560	630	.0180	.0236	.0236	.0307	.0307	.0386	.0100	.0140	.160	.224	.360	.470	.0079	.0122	.0170
630	710	.0201	.0264	.0264	.0335	.0335	.0429	.0120	.0160	.192	.256	.410	.510	.0087	.0130	.0185
710	800	.0224	.0295	.0295	.0378	.0378	.0480	.0130	.0180	.208	.288	.450	.590	.0094	.0154	.0210
800	900	.0252	.0331	.0331	.0421	.0421	.0539	.0140	.0200	.224	.320	.490	.650	.0110	.0169	.0230
900	1000	.0280	.0366	.0366	.0470	.0470	.0600	.0160	.0220	.256	.352	.550	.730	.0122	.0185	.0260

For Pe less than 0.13Cr, use the lower half of the reduction range. For heavier loads Pe greater than 0.13Cr, carburized or TL inner rings should be specified and the upper half of the range can be used.

Radial internal clearance can be measured during mounting using a feeler gauge or other appropriate gauges. In this process, the clearances for both rows of rollers must be measured simultaneously and the two values kept roughly the same by adjusting the relative position of the outer and inner rings. This is shown in Fig. 1. The average of the two measurements taken for both rows may be used as the residual internal clearance.

In large bearings, the outer ring may deform slightly into an elliptical shape due to its own weight. In this case, for best results, measurements should be taken at locations **a**, **b**, and **c** (see Fig. 2) and entered into the following equation:

$$\text{radial clearance} = (a + b + c)/2$$

This method is used where the bearing is resting on its outer ring (radial clearance **c** at bottom). When a self-aligning ball bearing is mounted on a shaft adapter, sufficient clearance for easy alignment of the outer ring must be allowed.

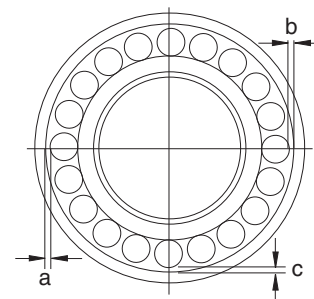
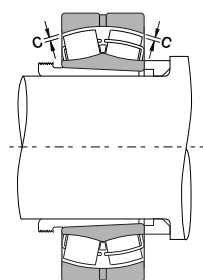

Figure 1

Figure 2

INSPECTING AND TROUBLESHOOTING

After mounting has been completed, a running test should be conducted to determine that the bearing has been mounted properly.

Small machines may be manually operated to assure that they rotate smoothly. Items to be checked include sticking due to foreign matter, visible flaws, uneven torque, and excessive torque caused by inadequate clearance, mounting error or seal friction.

Large machines which cannot be operated manually, may be started with no load, then the power immediately cut off to allow the machine to coast to a stop. There should be no abnormal vibration, noise or contact between rotating parts. Normal powered operation may be started after this examination. Powered operation should be started slowly, without load, and the operation should be observed until it is determined that no abnormalities exist. Items to be checked during the test operation include abnormal noise, excessive rise of bearing temperature, leakage and discoloration of lubricants. Abnormal noise conditions are indicated by a loud metallic sound or other irregular noise. Possible causes of noise may include incorrect lubrication, poor alignment of the shaft and housing, and foreign matter in the bearing.

Bearing temperature may generally be estimated by the temperature of the outside surface of the housing, but it is more desirable to directly measure the temperature of the outer ring using oil holes for access. Bearing temperature should rise gradually to the steady state level within one to two hours after operation. If the bearing or mountings are improper, bearing temperature may increase rapidly and become abnormally high. Possible causes may include an excessive amount of lubricant, insufficient clearance, incorrect mounting, or excessive friction of the seals. In the case of high speed operation, an incorrect selection of bearing type or lubricating method may also cause an abnormal temperature rise.

Possible causes and countermeasures for operating irregularities are shown in Table 10.57 on page 350.

Table 10.57 — Causes and Countermeasures for Operating Irregularities

	Irregularities	Possible Causes	Countermeasures
Introduction Ball Bearings Cylindrical Roller Bearings Spherical Roller Bearings Tapered Roller Bearings Thrust Bearings Spilt Pillow Blocks Super Precision Bearings	Noise	Abnormal Load	Correction of fit, internal clearance, preload, position of housing shoulder, etc.
		Incorrect mounting	Correction of alignment of shaft and housing, accuracy of mounting method.
		Insufficient or improper lubricant	Replenish lubricant or select proper lubricant.
		Squeaking noise	Replacement by low-noise bearings, selection of small clearance bearings.
		Sliding of balls	Adjustment of preload, selection of small clearance bearings, or adoption of softer grease.
		Contact of rotating parts	Correction of labyrinth seal, etc.
	Loud Regular Sound	Flaws, corrosion, or scratches on the raceways	Replacement of bearing, cleaning, improvement of seals, and usage of clean lubricant.
		Brinelling	Replacement of bearing and careful handling.
		Flaking on the raceways	Replacement of bearing
	Irregular Sound	Excessive clearance	Correction of fit and clearance and correction of preload
Penetration by foreign particles		Replacement of bearing, cleaning, improvement of seals, and relubrication using clean lubricant.	
Flaws or flaking on the ball surfaces		Replacement of bearing	
Excessive amount of lubricant		Reduce amount of lubricant, select stiffer grease.	
Abnormal Temperature Rise	Insufficient or improper lubricant	Replenish lubricant or select proper lubricant.	
	Abnormal load	Correction of fit, internal clearance, preload, position of housing shoulder.	
	Incorrect mounting	Correction of alignment of shaft and housing, accuracy of mounting, or mounting method.	
	Creep of fitted surfaces, excessive seal friction.	Correction of seals, replacement of bearing, correction of fit or mounting.	
Vibration	Brinelling	Replacement of bearings and careful handling.	
	Flaking	Replacement of bearing	
	Incorrect mounting	Correction of squareness between shaft and housing shoulder or side of spacer.	
	Penetration by foreign particles	Replacement of bearing, cleaning, correction of seals.	
Leakage or Discoloration of Lubricant	To much lubrication. Penetration by foreign particles or abrasion chips.	Reduce amount of lubricant, select stiffer grease. Replace bearing or lubricant. Clean housing and adjacent parts.	

Linear Motion

Rolling Mill Bearings

Engineering Section

HOW TO DISMOUNT BEARINGS

It may be necessary to remove bearings for periodic inspection or for other reasons. If the removed bearing is to be used again, it should be dismantled as carefully as when it was mounted. If the bearing has a tight fit, removal may be difficult. Dismounting procedures and the sequence of removal should be studied carefully before beginning the job.

Dismounting of Outer Rings

Housings are not normally supplied with facilities to allow easy bearing removal. However, if it is necessary to periodically remove the bearing for inspection or replacement, special features can be incorporated to ease removal. One method is to provide tapped holes, in a minimum of three places equally spaced as illustrated in Figure 10.58. Larger bearings will require more holes. By placing bolts in the holes and tightening evenly, the bearing will be forced out of the housing.

Another method is to provide slots in the housing shoulder as shown here. This allows the use of a press to allow safe removal of the bearing.

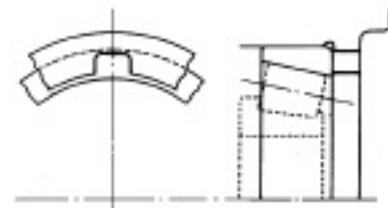

Dismounting of Bearings with Cylindrical Bores

If the mounting design allows space to press out the inner ring, this is an easy and fast method. In this method, the withdrawal force should be imposed only on the inner ring. When it is not possible to use a press, bearing pullers like those shown in Figure 10.58 are often used. The claws of these tools must fully engage the face of the inner ring, therefore it may be necessary to cut grooves in the shoulder to accommodate the tools.

The oil injection method is usually used for the withdrawal of large bearings. Withdrawal is achieved easily by means of oil pressure applied through holes in the shaft. In the case of extra wide bearings, the oil injection method is often used along with bearing pullers.

Induction heating is used to remove the inner rings of rollneck type, four row cylindrical roller bearings. The inner rings are expanded by brief local heating and then withdrawn.

Dismounting of Bearings with Tapered Bores

When dismantling relatively small bearings with adapter sleeves, the inner ring is held by a backing ring fastened to the shaft and the nut is loosened several turns. This is followed by hammering on the sleeve using a suitable tool. See Figure 10.58. It may be possible to dismount a withdrawal sleeve by tightening the removal nut. If this procedure is difficult, it may be possible to drill and tap bolt holes in the nut and withdraw the sleeve by tightening the bolts. The two methods for removal of the sleeve are illustrated in Figure 10.58.

Large bearings with tapered bores may be withdrawn easily using oil pressure. Figure 10.58 illustrates the removal of a bearing by forcing oil under pressure through a hole and groove in a tapered shaft to expand the inner ring. When this method is used, the bearing may suddenly move axially when interference is relieved, so a stop nut is recommended for protection. Figure 10.58 also shows a withdrawal using a hydraulic nut.

Introduction

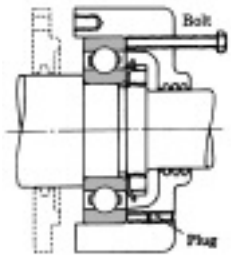

Removal of Outer Ring with Dismounting Bolts

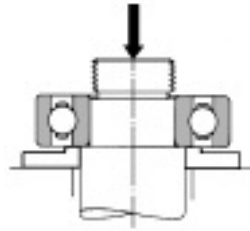

Removal of Inner Ring Using a Press

Ball Bearings

Cylindrical Roller Bearings

Spherical Roller Bearings

Tapered Roller Bearings

Thrust Bearings

Split Pillow Blocks

Super Precision Bearings

Linear Motion

Rolling Mill Bearings

Engineering Section

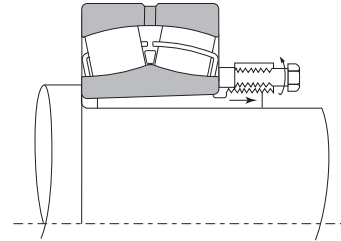
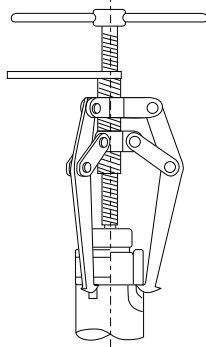
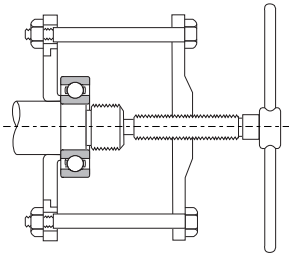

Removal of Withdrawal Sleeve with Withdrawal Nut

Removal of Inner Ring with Withdrawal Tools

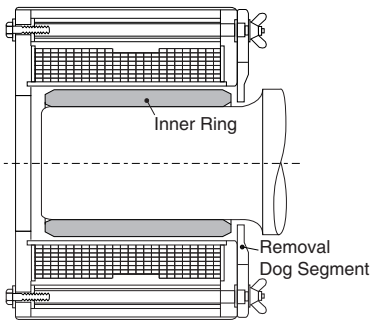

Removal of Inner Ring Using an Induction Heater

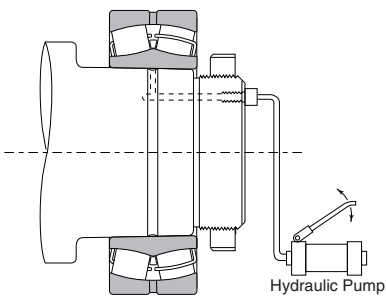
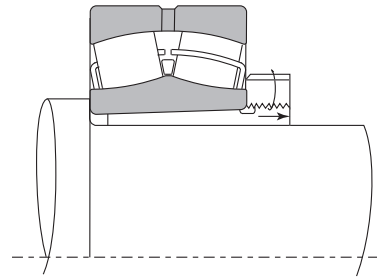

Removal Using Oil Injection

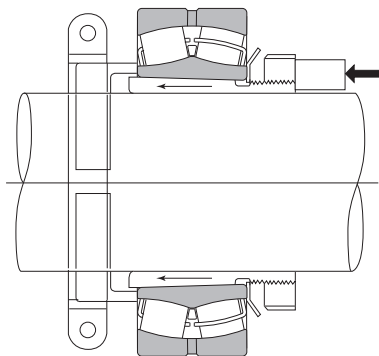

Removal of Adapter with Stop and Axial Pressure

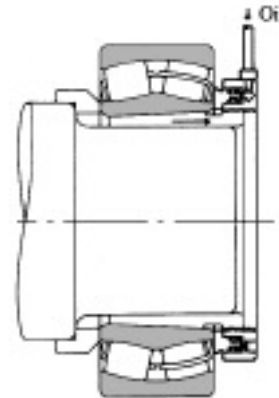

Removal Using a Hydraulic Nut

CLEANING, INSPECTION AND EVALUATION

Cleaning Bearings

When bearings are inspected, their appearance should first be recorded and the amount and condition of the residual lubricant checked. After the lubricant has been sampled for examination, the bearing should be cleaned. In general, light oil or kerosene may be used as a washing solution. Dismounted bearings should first be given a preliminary cleaning followed by a finishing rinse. Each cleaning tank should be provided with a metal net to suspend the bearings in the oil without touching either the sides or bottom of the tank.

If the bearings are rotated with foreign matter in them during cleaning, the raceways may be damaged. The lubricant and other deposits should be removed in the oil bath during the initial rough cleaning with a brush or other means. After the bearing is relatively clean, it should be given a finishing rinse. The bearing should be rotated while immersed in the rinsing oil. The rinsing oil must always be kept clean.

Inspection and Evaluation

After being thoroughly cleaned, bearings should be examined for the condition of their raceways and external surfaces, the amount of cage wear, the increase in internal clearance and degradation of tolerances. These must be carefully checked to determine the possibility of bearing reuse.

In the case of small non-separable ball bearings, hold the bearing horizontally in one hand and rotate the outer ring to confirm that it turns smoothly. Separable bearings such as tapered roller bearings, may be checked by individually examining their rolling elements and the outer ring raceway. Large bearings cannot be rotated manually. However, the rolling elements, raceway surfaces, cages and contact surface of the ribs should be carefully examined visually.

The determination to reuse a bearing should be made only after considering the degree of bearing wear, the function of the machine, the importance of the bearing in the machine, operating condition, and the time until next inspection. If any of the following defects exist, the bearing should be replaced:

- Cracks or dents in the inner or outer ring raceways, rolling elements or cage
- Flaking of the raceways or rolling elements
- Significant scratching of the raceway surfaces, ribs or rolling elements
- Worn cages or loose rivets
- Rust or flaws on the raceway surfaces or rolling elements
- Significant impact or brinell traces on the raceway surfaces or rolling elements
- Discoloration by heat
- Significant damage to the seals or shields of grease sealed bearings

MAINTENANCE AND INSPECTION

Correcting Irregularities

In order to maintain the original performance of a bearing for as long as possible, proper maintenance and inspection should be performed. If proper procedures are used, many bearing problems can be avoided. Periodic maintenance following specified procedures is mandatory. This includes supervision of operating conditions, supply or replacement of lubricants, and regular periodic inspection.

Items that should be regularly checked during operation include bearing noise, vibration, temperature and lubrication. If an irregularity is found during operation, the cause should be

Introduction

determined and the proper corrective action taken immediately. If necessary, the bearing should be dismantled and examined in detail. Refer to Table 10.57 on page 350 for causes and corrections of operating irregularities.

Ball Bearings

It is very important to detect signs of irregularities early in operation. The **NSK** Bearing Monitor is a device that checks the condition of bearings and gives a warning of any abnormality. It can also be used to stop the machine automatically in order to prevent serious damage. It also helps to improve the level of and attention to maintenance schedules and procedures. Contact **NSK** for further information.

Cylindrical Roller Bearings

Bearing Failures – Cause and Correction

In general, if rolling bearings are correctly used, they will survive to their predicted fatigue life. Premature failure is usually caused by improper mounting or dismounting, improper lubrication, penetration of foreign material, or inadequate inspection and maintenance.

Spherical Roller Bearings

It is often difficult to determine the real causes of premature failure. If all the conditions leading up to the time of failure are studied, it may be possible to avoid or reduce similar failures in the future.

The most frequent types of bearing failure, along with causes and corrective actions, are shown in Table 10.59 on page 355.

Tapered Roller Bearings

Thrust Bearings

Split Pillow Blocks

Super Precision Bearings

Linear Motion

Rolling Mill Bearings

Engineering Section

Table 10.59 — Causes and Countermeasures for Bearing Failures

	Type of Failure	Probable Cause	Counter Measures
Flaking	Flaking of one-side of the raceway of radial bearings Flaking of the raceways of double row bearings.	Abnormal axial load.	A loose fit should be used when mounting the outer ring of free-end bearings to allow axial expansion of the shaft.
	Flaking of the raceway in a symmetrical pattern	Out of roundness of the housing bore.	Correct the faulty housing.
	Flaking pattern inclined relative to the raceway in radial ball bearings. Flaking near the edge of the raceway and rolling surfaces in roller bearings.	Improper mounting, deflection of shaft, inadequate centering, inadequate tolerances for shaft and housing.	Use care in mounting and centering, select a bearing with a larger clearance, and correct the squareness of the shaft and housing shoulder.
	Flaking of raceway with same spacing as rolling elements.	Large shock load during mounting, rusting while bearing is out of operation for a prolonged period.	Use care in mounting and apply a rust preventive when machine operation is suspended for a long time.
	Premature flaking of raceways and rolling elements.	Insufficient clearance, excessive load, improper lubricant, rust, etc.	Select proper fit, bearing clearance, and lubricant.
	Premature flaking of duplex bearing	Excessive preload.	Adjust the preload.
Scoring and Smearing	Scoring or smearing between raceway and rolling surfaces.	Inadequate initial lubrication, excessively hard grease and high acceleration in starting.	Use a softer grease and avoid rapid acceleration.
	Spiral scoring or smearing of raceway surface of thrust ball bearing.	Raceway rings are not parallel and excessive speed.	Correct the mounting, apply a preload, or select another bearing type.
	Scoring or smearing between the end face of the rollers and guide rib.	Inadequate lubrication, incorrect mounting and large axial load.	Select proper lubricants and modify the mounting.
Cracks	Crack in outer or inner ring.	Excessive shock load, excessive interference fit, incorrect shaft cylindricity, improper amount of sleeve taper, large fillet radius, development of thermal cracks and advancement of flaking.	Examine the loading conditions, modify the fit of bearing sleeve. The fillet radius must be smaller than the bearing chamfer.
	Crack in rolling element. Break in rib.	Advancement of flaking, shock applied to the rib during mounting or dropped during handling.	Be careful in handling and mounting.
	Fracture of cage.	Abnormal loading of cage due to incorrect mounting and improper lubrication.	Reduce the mounting error and review the lubricating method and lubricant.
Indentation	Indentations on raceway in same pattern as rolling elements	Shock load during mounting or excessive load when not rotating.	Use care in handling.
	Indentations on raceway and rolling elements.	Foreign matter such as metallic chips or sand.	Clean the housing, improve the seals, and use a clean lubricant.
Abnormal Wear	False brinelling (phenomenon similar to brinelling).	Vibration of the bearing without rotation during shipment or rocking motion of small amplitude.	Secure the shaft and housing, use oil as a lubricant and reduce vibration by applying a preload.
	Fretting.	Slight wearing of the fitting surface.	Increase interference and apply oil.
	Wearing of raceway, rolling elements, rib and cage.	Penetration by foreign matter, incorrect lubrication, and rust.	Use a different type of seal, clean the housing, and use a clean lubricant.
	Creep.	Insufficient interference or insufficient tightening of sleeve	Modify the fit or tighten the sleeve.
Seizure	Discoloration or welding of raceway, rolling elements, and rib.	Insufficient clearance, incorrect lubrication, or improper mounting.	Review the internal clearance and bearing fit, supply an adequate amount of the proper lubricant and improve the mounting method and related parts.
Electric Burns	Fluting or corrugation.	Melting due to electric arcing.	Install a ground wire to stop flow of electricity or insulate the bearing.
Corrosion and Rust	Rust and corrosion of fitting surfaces and bearing interior.	Condensation of water from the air, fretting, or penetration by corrosive substances.	Use care in storing and avoid high temperatures and high humidity; treatment for rust prevention is necessary when the operation is suspended for a long time.

Introduction

Ball Bearings

Cylindrical Roller Bearings

Spherical Roller Bearings

Tapered Roller Bearings

Thrust Bearings

Split Pillow Blocks

Super Precision Bearings

Linear Motion

Rolling Mill Bearings

Engineering Section

Appendix A –Tolerances for Shaft Diameters

Units: Inch

Shaft Diameter (mm)		Bearing Bore Tolerance	Shaft Tolerance								
over	incl		ABEC1	g6	h6	h9	h10	js5	js6	k5	k6
3	6	+0	-0.0002	+0	+0	+0	+0	±0.0001	±0.0002	+0.0002	+0.0004
		-0.0003	-0.0005	-0.0003	-0.0012	-0.0019				+0	+0
6	10	+0	-0.0002	+0	+0	+0	+0	±0.0001	±0.0002	+0.0003	+0.0004
		-0.0003	-0.0006	-0.0004	-0.0014	-0.0023				+0	+0
10	18	+0	-0.0002	+0	+0	+0	+0	±0.0002	±0.0002	+0.0004	+0.0005
		-0.0003	-0.0007	-0.0004	-0.0017	-0.0028				+0	+0
18	30	+0	-0.0003	+0	+0	+0	+0	±0.0002	±0.0003	+0.0004	+0.0006
		-0.0004	-0.0008	-0.0005	-0.0020	-0.0033				+0.0001	+0.0001
30	50	+0	-0.0004	+0	+0	+0	+0	±0.0002	±0.0003	+0.0005	+0.0007
		-0.0005	-0.0010	-0.0006	-0.0024	-0.0039				+0.0001	+0.0001
50	80	+0	-0.0004	+0	+0	+0	+0	±0.0003	±0.0004	+0.0006	+0.0008
		-0.0006	-0.0011	-0.0007	-0.0029	-0.0047				+0.0001	+0.0001
80	120	+0	-0.0005	+0	+0	+0	+0	±0.0003	±0.0004	+0.0007	+0.0010
		-0.0008	-0.0013	-0.0009	-0.0034	-0.0055				+0.0001	+0.0001
120	180	+0	-0.0006	+0	+0	+0	+0	±0.0004	±0.0005	+0.0008	+0.0011
		-0.0010	-0.0015	-0.0010	-0.0039	-0.0063				+0.0001	+0.0001
180	250	+0	-0.0006	+0	+0	+0	+0	±0.0004	±0.0006	+0.0009	+0.0013
		-0.0012	-0.0017	-0.0011	-0.0045	-0.0073				+0.0002	+0.0002
250	315	+0	-0.0007	+0	+0	+0	+0	±0.0005	±0.0006	+0.0011	+0.0014
		-0.0014	-0.0019	-0.0013	-0.0051	-0.0083				+0.0002	+0.0002
315	400	+0	-0.0007	+0	+0	+0	+0	±0.0005	±0.0007	+0.0011	+0.0016
		-0.0016	-0.0021	-0.0014	-0.0055	-0.0091				+0.0002	+0.0002
400	500	+0	-0.0008	+0	+0	+0	+0	±0.0005	±0.0008	+0.0013	+0.0018
		-0.0018	-0.0024	-0.0016	-0.0061	-0.0098				+0.0002	+0.0002
500	630	+0	-0.0009	+0	+0	+0	+0		±0.0009		+0.0017
		-0.0020	-0.0026	-0.0017	-0.0069	-0.0110					+0
630	800	+0	-0.0009	+0	+0	+0	+0		±0.0010		+0.0020
		-0.0030	-0.0029	-0.0020	-0.0079	-0.0126					+0
800	1000	+0	-0.0010	+0	+0	+0	+0		±0.0011		+0.0022
		-0.0039	-0.0032	-0.0022	-0.0091	-0.0142					+0
1000	1250	+0	-0.0011	+0	+0	+0	+0		±0.0013		+0.0026
		-0.0049	-0.0037	-0.0026	-0.0102	-0.0165					+0
1250	1600	+0	-0.0012	+0	+0	+0	+0		±0.0015		+0.0031
		-0.0063	-0.0043	-0.0031	-0.0122	-0.0197					+0
1600	2000	+0	-0.0013	+0	+0	+0	+0		±0.0018		+0.0036
		-0.0079	-0.0049	-0.0036	-0.0146	-0.0236					+0

Directions: The shaft tolerances are determined by adding the top number in the tolerance group to the shaft size and adding the bottom number to the shaft size. This provides the maximum shaft size and the minimum shaft size, respectively.

For example:

Shaft size = 0.4724”

Application = Electric Motor (Recommended shaft fit js6)

Shaft Tolerance (max) = 0.4724” + 0.0002” = 0.4726”

Shaft Tolerance (min) = 0.4724” - 0.0002” = 0.4722”

Appendix A –Tolerances for Shaft Diameters (continued)

Units: Inch						Units: Inch			
Shaft Diameter (mm)		Shaft Tolerance				Shaft Diameter (inch)		Shaft Tolerance	
over	incl	m5	m6	n6	p6	over	incl	r6	r7
3	6	+0.0004	+0.0005	+0.0006	+0.0008	3	6	+0.0009	+0.0007
		+0.0002	+0.0002	+0.0003	+0.0005			+0.0006	+0.0006
6	10	+0.0005	+0.0006	+0.0007	+0.0009	6	10	+0.0011	+0.0013
		+0.0002	+0.0002	+0.0004	+0.0006			+0.0007	+0.0007
10	18	+0.0006	+0.0007	+0.0009	+0.0011	10	18	+0.0013	+0.0016
		+0.0003	+0.0003	+0.0005	+0.0007			+0.0009	+0.0009
18	30	+0.0007	+0.0008	+0.0011	+0.0014	18	30	+0.0016	+0.0019
		+0.0003	+0.0003	+0.0006	+0.0009			+0.0011	+0.0011
30	50	+0.0008	+0.0010	+0.0013	+0.0017	30	50	+0.0020	+0.0023
		+0.0004	+0.0004	+0.0007	+0.0010			+0.0013	+0.0013
50	80	+0.0009	+0.0012	+0.0015	+0.0020	50	65	+0.0024	+0.0028
		+0.0004	+0.0004	+0.0008	+0.0013			+0.0016	+0.0016
80	120	+0.0011	+0.0014	+0.0018	+0.0023	65	80	+0.0024	+0.0029
		+0.0005	+0.0005	+0.0009	+0.0015			+0.0017	+0.0017
120	180	+0.0013	+0.0016	+0.0020	+0.0027	80	100	+0.0029	+0.0034
		+0.0006	+0.0006	+0.0011	+0.0017			+0.0020	+0.0020
180	250	+0.0015	+0.0018	+0.0024	+0.0031	100	120	+0.0030	+0.0035
		+0.0007	+0.0007	+0.0012	+0.0020			+0.0021	+0.0021
250	315	+0.0017	+0.0020	+0.0026	+0.0035	120	140	+0.0035	+0.0041
		+0.0008	+0.0008	+0.0013	+0.0022			+0.0025	+0.0025
315	400	+0.0018	+0.0022	+0.0029	+0.0039	140	160	+0.0035	+0.0041
		+0.0008	+0.0008	+0.0015	+0.0024			+0.0026	+0.0026
400	500	+0.0020	+0.0025	+0.0031	+0.0043	160	180	+0.0037	+0.0043
		+0.0009	+0.0009	+0.0016	+0.0027			+0.0027	+0.0027
500	630		+0.0028	+0.0035	+0.0048	180	200	+0.0042	+0.0048
			+0.0010	+0.0017	+0.0031			+0.0030	+0.0030
630	800		+0.0031	+0.0039	+0.0054	200	225	+0.0043	+0.0050
			+0.0012	+0.0020	+0.0035			+0.0031	+0.0031
800	1000		+0.0035	+0.0044	+0.0061	225	250	+0.0044	+0.0051
			+0.0013	+0.0022	+0.0039			+0.0033	+0.0033
1000	1250		+0.0042	+0.0052	+0.0073	250	280	+0.0050	+0.0057
			+0.0016	+0.0026	+0.0047			+0.0037	+0.0037
1250	1600		+0.0050	+0.0061	+0.0086	280	315	+0.0051	+0.0059
			+0.0019	+0.0031	+0.0055			+0.0039	+0.0039
1600	2000		+0.0059	+0.0072	+0.0103	315	355	+0.0057	+0.0065
			+0.0023	+0.0036	+0.0067			+0.0043	+0.0043
						355	400	+0.0057	+0.0067
								+0.0045	+0.0045
						400	450	+0.0065	+0.0074
								+0.0050	+0.0050
						450	500	+0.0068	+0.0077
								+0.0052	+0.0052
						500	560	+0.0076	+0.0087
								+0.0059	+0.0059
						560	630	+0.0078	+0.0089
								+0.0061	+0.0061
						630	710	+0.0089	+0.0100
								+0.0069	+0.0069
						710	800	+0.0093	+0.0104
								+0.0073	+0.0073
						800	900	+0.0105	+0.0118
								+0.0083	+0.0083
						900	1000	+0.0109	+0.0122
								+0.0087	+0.0087
						1000	1120	+0.0124	+0.0140
								+0.0098	+0.0098
						1120	1250	+0.0128	+0.0144
								+0.0102	+0.0102
						1250	1400	+0.0149	+0.0167
								+0.0118	+0.0118
						1400	1600	+0.0161	+0.0179
								+0.0130	+0.0130
						1600	1800	+0.0182	+0.0205
								+0.0146	+0.0146
						1800	2000	+0.0194	+0.0217
								+0.0157	+0.0157

Introduction

Ball Bearings

Cylindrical Roller Bearings

Spherical Roller Bearings

Tapered Roller Bearings

Thrust Bearings

Split Pillow Blocks

Super Precision Bearings

Linear Motion

Rolling Mill Bearings

Engineering Section

Appendix B – Tolerances for Housing Bore Diameters

Units: Inch

	Housing Bore Diameter (mm)		Bearing O.D. Tolerance	Housing Bore Tolerance						
	over	incl		ABEC1	G7	H6	H7	H8	J6	J7
Ball Bearings	10	18	+0	+0.0009	+0.0004	+0.0007	+0.0011	+0.0002	+0.0004	±0.0002
			-0.0003	+0.0002	+0	+0	+0	-0.0002	-0.0003	
Ball Bearings	18	30	+0	+0.0011	+0.0005	+0.0008	+0.0013	+0.0003	+0.0005	±0.0003
			-0.0004	+0.0003	+0	+0	+0	-0.0002	-0.0004	
Cylindrical Roller Bearings	30	50	+0	+0.0013	+0.0006	+0.0010	+0.0015	+0.0004	+0.0006	±0.0003
			-0.0004	+0.0004	+0	+0	+0	-0.0002	-0.0004	
Cylindrical Roller Bearings	50	80	+0	+0.0016	+0.0007	+0.0012	+0.0018	+0.0005	+0.0007	±0.0004
			-0.0005	+0.0004	+0	+0	+0	-0.0002	-0.0005	
Cylindrical Roller Bearings	80	120	+0	+0.0019	+0.0009	+0.0014	+0.0021	+0.0006	+0.0009	±0.0004
			-0.0006	+0.0005	+0	+0	+0	-0.0002	-0.0005	
Cylindrical Roller Bearings	120	150	+0	+0.0021	+0.0010	+0.0016	+0.0025	+0.0007	+0.0010	±0.0005
			-0.0007	+0.0006	+0	+0	+0	-0.0003	-0.0006	
Spherical Roller Bearings	150	180	+0	+0.0021	+0.0010	+0.0016	+0.0025	+0.0007	+0.0010	±0.0005
			-0.0010	+0.0006	+0	+0	+0	-0.0003	-0.0006	
Spherical Roller Bearings	180	250	+0	+0.0024	+0.0011	+0.0018	+0.0028	+0.0009	+0.0012	±0.0006
			-0.0012	+0.0006	+0	+0	+0	-0.0003	-0.0006	
Spherical Roller Bearings	250	315	+0	+0.0027	+0.0013	+0.0020	+0.0032	+0.0010	+0.0014	±0.0006
			-0.0014	+0.0007	+0	+0	+0	-0.0003	-0.0006	
Spherical Roller Bearings	315	400	+0	+0.0030	+0.0014	+0.0022	+0.0035	+0.0011	+0.0015	±0.0007
			-0.0016	+0.0007	+0	+0	+0	-0.0003	-0.0007	
Tapered Roller Bearings	400	500	+0	+0.0033	+0.0016	+0.0025	+0.0038	+0.0013	+0.0017	±0.0008
			-0.0018	+0.0008	+0	+0	+0	-0.0003	-0.0008	
Tapered Roller Bearings	500	630	+0	+0.0036	+0.0017	+0.0028	+0.0043	-	-	±0.0009
			-0.0020	+0.0009	+0	+0	+0	-	-	
Tapered Roller Bearings	630	800	+0	+0.0041	+0.0020	+0.0031	+0.0049	-	-	±0.0010
			-0.0030	+0.0009	+0	+0	+0	-	-	
Thrust Bearings	800	1000	+0	+0.0046	+0.0022	+0.0035	+0.0055	-	-	±0.0011
			-0.0039	+0.0010	+0	+0	+0	-	-	
Thrust Bearings	1000	1250	+0	+0.0052	+0.0026	+0.0041	+0.0065	-	-	±0.0013
			-0.0049	+0.0011	+0	+0	+0	-	-	
Thrust Bearings	1250	1600	+0	+0.0061	+0.0031	+0.0049	+0.0077	-	-	±0.0015
			-0.0063	+0.0012	+0	+0	+0	-	-	
Thrust Bearings	1600	2000	+0	+0.0072	+0.0036	+0.0059	+0.0091	-	-	±0.0018
			-0.0079	+0.0013	+0	+0	+0	-	-	
Split Pillow Blocks	2000	2500	+0	+0.0082	+0.0043	+0.0069	+0.0110	-	-	±0.0022
			-0.0098	+0.0013	+0	+0	+0	-	-	

Directions: The housing bore tolerances are determined by adding the top number in the tolerance group to the housing bore size and adding the bottom number to the housing bore size. This provides the maximum and minimum housing bore, respectively.

For example:

Housing bore = 1.2598”

Application = Electric Motor (Recommended Housing fit H7)

Housing Bore Tolerance (max) = 1.2598” + 0.0007” = 1.2605”

Housing Bore Tolerance (min) = 1.2598” + 0” = 1.2598”

Appendix B – Tolerances for Housing Bore Diameters (continued)

Units: Inch

Housing Bore Diameter (mm)		Housing Bore Tolerance							
over	incl	JS7	K6	K7	M6	M7	N6	N7	P7
10	18	±0.0004	+0.0001 -0.0004	+0.0002 -0.0005	-0.0002 -0.0006	+0 -0.0007	-0.0004 -0.0008	-0.0002 -0.0009	-0.0004 -0.0011
18	30	±0.0004	+0.0001 -0.0004	+0.0002 -0.0006	-0.0002 -0.0007	+0 -0.0008	-0.0004 -0.0009	-0.0003 -0.0011	-0.0006 -0.0014
30	50	±0.0005	+0.0001 -0.0005	+0.0003 -0.0007	-0.0002 -0.0008	+0 -0.0010	-0.0005 -0.0011	-0.0003 -0.0013	-0.0007 -0.0017
50	80	±0.0006	+0.0002 -0.0006	+0.0004 -0.0008	-0.0002 -0.0009	+0 -0.0012	-0.0006 -0.0013	-0.0004 -0.0015	-0.0008 -0.0020
80	120	±0.0007	+0.0002 -0.0007	+0.0004 -0.0010	-0.0002 -0.0011	+0 -0.0014	-0.0006 -0.0015	-0.0004 -0.0018	-0.0009 -0.0023
120	180	±0.0008	+0.0002 -0.0008	+0.0005 -0.0011	-0.0003 -0.0013	+0 -0.0016	-0.0008 -0.0018	-0.0005 -0.0020	-0.0011 -0.0027
180	250	±0.0009	+0.0002 -0.0009	+0.0005 -0.0013	-0.0003 -0.0015	+0 -0.0018	-0.0009 -0.0020	-0.0006 -0.0024	-0.0013 -0.0031
250	315	±0.0010	+0.0002 -0.0011	+0.0006 -0.0014	-0.0004 -0.0016	+0 -0.0020	-0.0010 -0.0022	-0.0006 -0.0026	-0.0014 -0.0035
315	400	±0.0011	+0.0003 -0.0011	+0.0007 -0.0016	-0.0004 -0.0018	+0 -0.0022	-0.0010 -0.0024	-0.0006 -0.0029	-0.0016 -0.0039
400	500	±0.0012	+0.0003 -0.0013	+0.0007 -0.0018	-0.0004 -0.0020	+0 -0.0025	-0.0011 -0.0026	-0.0007 -0.0031	-0.0018 -0.0043
500	630	±0.0014	+0 -0.0017	+0 -0.0028	-0.0010 -0.0028	-0.0010 -0.0038	-0.0017 -0.0035	-0.0017 -0.0045	-0.0031 -0.0058
630	800	±0.0016	+0 -0.0020	+0 -0.0031	-0.0012 -0.0031	-0.0012 -0.0043	-0.0020 -0.0039	-0.0020 -0.0051	-0.0035 -0.0066
800	1000	±0.0018	+0 -0.0022	+0 -0.0035	-0.0013 -0.0035	-0.0013 -0.0049	-0.0013 -0.0044	-0.0022 -0.0057	-0.0039 -0.0075
1000	1250	±0.0020	+0 -0.0026	+0 -0.0041	-0.0016 -0.0042	-0.0016 -0.0057	-0.0026 -0.0052	-0.0026 -0.0067	-0.0047 -0.0089
1250	1600	±0.0024	+0 -0.0031	+0 -0.0049	-0.0019 -0.0050	-0.0019 -0.0068	-0.0031 -0.0061	-0.0031 -0.0080	-0.0055 -0.0104
1600	2000	±0.0030	+0 -0.0036	+0 -0.0059	-0.0023 -0.0059	-0.0023 -0.0082	-0.0036 -0.0072	-0.0036 -0.0095	-0.0067 -0.0126
2000	2500	±0.0034	+0 -0.0043	+0 -0.0069	-0.0027 -0.0070	-0.0027 -0.0096	-0.0043 -0.0087	-0.0043 -0.0112	-0.0077 -0.0146

Introduction

Ball Bearings

Cylindrical Roller Bearings

Spherical Roller Bearings

Tapered Roller Bearings

Thrust Bearings

Split Pillow Blocks

Super Precision Bearings

Linear Motion

Rolling Mill Bearings

Engineering Section

NSK NSK NSK NSK NSK NSK NSK NSK

	Bearing No.			Bearing No.			Bearing No.			Bearing No.		
	(prefix, no., Suffix)	Section	Page	(prefix, no., Suffix)	Section	Page	(prefix, no., Suffix)	Section	Page	(prefix, no., Suffix)	Section	Page
Introduction	2PSL240-1UPA	Spherical	99	90BNC10SN24	Precision	204	493	Tapered	136	2314	Ball Bearings	28
	2SL180-2UPA	Spherical	68	90BNR10H	Precision	208	495	Tapered	136	2315	Ball Bearings	28
	2SL180-2UPA	Spherical	99	90BNR10S	Precision	206	497	Tapered	136	2316	Ball Bearings	28
	2SL200-2UPA	Spherical	68	90BTR10S	Precision	216	552A	Tapered	136	2720	Tapered	134
	2SL200-2UPA	Spherical	99	95BAR10S	Precision	214	553X	Tapered	136	2729	Tapered	134
	2SL220-2UPA	Spherical	68	95BNC10	Precision	202	560	Tapered	136	2788	Tapered	134
	2SL220-2UPA	Spherical	99	95BNC10SN24	Precision	204	560	Tapered	136	2788	Tapered	134
	2SL240-2UPA	Spherical	68	95BNR10H	Precision	208	563	Tapered	136	3200X	Ball Bearings	30
	2SL240-2UPA	Spherical	99	95BNR10S	Precision	206	567	Tapered	136	3201J	Ball Bearings	30
	2SL260-2UPA	Spherical	68	95BTR10S	Precision	216	572	Tapered	136	3202J	Ball Bearings	30
Ball Bearings	2SL260-2UPA	Spherical	99	100BAR10S	Precision	214	572	Tapered	136	3203J	Ball Bearings	30
	2SL280-2UPA	Spherical	68	100BNC10	Precision	202	575	Tapered	136	3204J	Ball Bearings	30
	2SL280-2UPA	Spherical	99	100BNC10SN24	Precision	204	580	Tapered	136	3205J	Ball Bearings	30
	2SL300-2UPA	Spherical	68	100BNR10H	Precision	208	592A	Tapered	136	3206J	Ball Bearings	30
	2SL300-2UPA	Spherical	99	100BNR10S	Precision	206	592A	Tapered	136	3207J	Ball Bearings	30
	2SL320-2UPA	Spherical	68	100BTR10S	Precision	216	592A	Tapered	136	3208J	Ball Bearings	30
	2SL320-2UPA	Spherical	99	101TAC145B	Precision	224	593	Tapered	136	3209J	Ball Bearings	30
	2SL340-2UPA	Spherical	68	105BAR10S	Precision	214	598	Tapered	136	3210J	Ball Bearings	30
	2SL340-2UPA	Spherical	99	105BNC10	Precision	202	598A	Tapered	136	3211J	Ball Bearings	30
	6BGR10H	Precision	212	105BNC10SN24	Precision	204	604	Ball Bearings	13	3212J	Ball Bearings	30
Cylindrical Roller Bearings	6BGR10S	Precision	210	105BTR10S	Precision	216	605	Ball Bearings	13	3213J	Ball Bearings	30
	7BGR10H	Precision	212	110BAR10S	Precision	214	606	Ball Bearings	13	3214J	Ball Bearings	30
	7BGR10S	Precision	210	110BNC10	Precision	202	607	Ball Bearings	13	3302J	Ball Bearings	30
	8BGR10H	Precision	212	110BNC10SN24	Precision	204	608	Ball Bearings	13	3303J	Ball Bearings	30
	8BGR10S	Precision	210	110BTR10S	Precision	216	608-5	Ball Bearings	13	3304J	Ball Bearings	30
	10BGR10H	Precision	212	120BAR10S	Precision	214	609	Ball Bearings	13	3305J	Ball Bearings	30
	10BGR10S	Precision	210	120BTR10S	Precision	216	623	Ball Bearings	13	3306J	Ball Bearings	30
	12BGR10H	Precision	212	130BAR10S	Precision	214	624	Ball Bearings	13	3307J	Ball Bearings	30
	12BGR10S	Precision	210	130BTR10S	Precision	216	625	Ball Bearings	13	3308J	Ball Bearings	30
	15BGR10H	Precision	212	230/1000CAME4	Spherical	80	626	Ball Bearings	13	3309J	Ball Bearings	30
Spherical Roller Bearings	15BGR10S	Precision	210	230/1060CAME4	Spherical	80	627	Ball Bearings	13	3310J	Ball Bearings	30
	17BGR10H	Precision	212	230/1120CAME4	Spherical	80	628	Ball Bearings	13	3311J	Ball Bearings	30
	17BGR10S	Precision	210	230/1250CAME4	Spherical	80	629	Ball Bearings	13	3312J	Ball Bearings	30
	20BGR10H	Precision	224	230/500CAME4	Spherical	80	634	Ball Bearings	13	3313J	Ball Bearings	30
	20BGR10S	Precision	212	230/530CAME4	Spherical	80	635	Ball Bearings	13	3314J	Ball Bearings	30
	20TAC47B	Precision	224	230/560CAME4	Spherical	80	638	Ball Bearings	13	3525	Tapered	134
	20TAC47XB	Precision	224	230/600CAME4	Spherical	80	653	Tapered	136	3578	Tapered	134
	23TAC62B	Precision	224	230/630CAME4	Spherical	80	653	Tapered	136	3720	Tapered	134
	25BGR10H	Precision	212	230/670CAME4	Spherical	80	663	Tapered	136	3782	Tapered	134
	25BGR10S	Precision	210	230/710CAME4	Spherical	80	665A	Tapered	136	3920	Tapered	136
Tapered Roller Bearings	25TAC62B	Precision	224	230/750CAME4	Spherical	80	684	Ball Bearings	13	3920	Tapered	136
	30BNC10	Precision	202	230/800CAME4	Spherical	80	684ZZW	Ball Bearings	13	3982	Tapered	136
	30BNC10SN24	Precision	204	230/850CAME4	Spherical	80	685	Ball Bearings	13	3984	Tapered	136
	30BNR10H	Precision	208	230/900CAME4	Spherical	80	685ZZW	Ball Bearings	13	05075	Tapered	132
	30BNR10S	Precision	206	230/950CAME4	Spherical	80	686	Ball Bearings	13	05079	Tapered	132
	30TAC62B	Precision	224	231/500CAME4	Spherical	84	686ZZW	Ball Bearings	13	05185	Tapered	132
	35BNC10	Precision	202	231/530CAME4	Spherical	84	687	Ball Bearings	13	05185	Tapered	132
	35BNC10SN24	Precision	204	231/560CAME4	Spherical	84	687ZZW	Ball Bearings	13	5200J	Ball Bearings	32
	35BNR10H	Precision	208	231/600CAME4	Spherical	84	689	Ball Bearings	13	5200TNG	Ball Bearings	32
	35BNR10S	Precision	206	231/630CAME4	Spherical	84	689ZZW	Ball Bearings	13	5201J	Ball Bearings	32
Thrust Bearings	35TAC62B	Precision	224	231/670CAME4	Spherical	84	693	Ball Bearings	13	5201TNG	Ball Bearings	32
	38TAC72B	Precision	224	231/710CAME4	Spherical	84	693ZZW	Ball Bearings	13	5202J	Ball Bearings	32
	40BD49V	Ball Bearings	44	231/750CAME4	Spherical	84	694	Ball Bearings	13	5202TNG	Ball Bearings	32
	40BNC10	Precision	202	231/800CAME4	Spherical	84	695	Ball Bearings	13	5203J	Ball Bearings	32
	40BNC10SN24	Precision	204	231/850CAME4	Spherical	84	696	Ball Bearings	13	5203TNG	Ball Bearings	32
	40BNR10H	Precision	208	231/900CAME4	Spherical	84	697	Ball Bearings	13	5204J	Ball Bearings	32
	40BNR10S	Precision	206	232/500CAME4	Spherical	88	698	Ball Bearings	13	5204TNG	Ball Bearings	32
	40TAC72B	Precision	224	232/530CAME4	Spherical	88	742	Tapered	136	5205J	Ball Bearings	32
	40TAC90B	Precision	224	232/560CAME4	Spherical	88	749	Tapered	136	5205TNG	Ball Bearings	32
	44TAC76B	Precision	224	232/600CAME4	Spherical	88	1200	Ball Bearings	26	5206J	Ball Bearings	32
Split Pillow Blocks	45BNC10	Precision	202	232/630CAME4	Spherical	88	1201	Ball Bearings	26	5206TNG	Ball Bearings	32
	45BNC10SN24	Precision	204	232/670CAME4	Spherical	88	1202	Ball Bearings	26	5207J	Ball Bearings	32
	45BNR10H	Precision	208	232/710CAME4	Spherical	88	1203	Ball Bearings	26	5207TNG	Ball Bearings	32
	45BNR10S	Precision	206	232/750CAME4	Spherical	88	1204	Ball Bearings	26	5208J	Ball Bearings	32
	45TAC100B	Precision	224	232/800CAME4	Spherical	88	1205	Ball Bearings	26	5208TNG	Ball Bearings	32
	45TAC100B	Precision	224	232/850CAME4	Spherical	88	1206	Ball Bearings	26	5209J	Ball Bearings	34
	45TAC75B	Precision	224	232/900CAME4	Spherical	88	1207	Ball Bearings	26	5209TNG	Ball Bearings	34
	50BNC10	Precision	202	239/1000CAME4	Spherical	90	1208	Ball Bearings	26	5210J	Ball Bearings	34
	50BNC10SN24	Precision	204	239/1060CAME4	Spherical	90	1209	Ball Bearings	26	5210TNG	Ball Bearings	34
	50BNR10H	Precision	208	239/1120CAME4	Spherical	90	1210	Ball Bearings	26	5211J	Ball Bearings	34
Super Precision Bearings	50BNR10S	Precision	206	239/1180CAME4	Spherical	90	1211	Ball Bearings	26	5211TNG	Ball Bearings	34
	50TAC100B	Precision	224	239/1250CAME4	Spherical	90	1212	Ball Bearings	26	5212J	Ball Bearings	34
	55BNC10	Precision	202	239/1400CAME4	Spherical	90	1213	Ball Bearings	26	5212TNG	Ball Bearings	34
	55BNC10SN24	Precision	204	239/500CAME4	Spherical	90	1214	Ball Bearings	26	5213J	Ball Bearings	34
	55BNR10H	Precision	208	239/530CAME4	Spherical	90	1215	Ball Bearings	26	5213TNG	Ball Bearings	34
	55BNR10S	Precision	206	239/560CAME4	Spherical	90	1301	Ball Bearings	26	5214J	Ball Bearings	34
	55TAC100B	Precision	224	239/600CAME4	Spherical	90	1302	Ball Bearings	26	5214TNG	Ball Bearings	34
	55TAC120B	Precision	224	239/630CAME4	Spherical	90	1303	Ball Bearings	26	5215J	Ball Bearings	34
	57TAC90B	Precision	224	239/670CAME4	Spherical	90	1304	Ball Bearings	26	5216J	Ball Bearings	34
	60BAR10S	Precision	214	239/710CAME4	Spherical	90	1305	Ball Bearings	26	5217J	Ball Bearings	34
Linear Motion	60BNC10	Precision	202	239/750CAME4	Spherical	90	1306	Ball Bearings	26	5302TNG	Ball Bearings	32
	60BNC10SN24	Precision	204	239/800CAME4	Spherical	90	1307	Ball Bearings	26	5303J	Ball Bearings	32
	60BNR10H	Precision	208	239/850CAME4	Spherical	90	1308	Ball Bearings	26	5303TNG	Ball Bearings	32
	60BNR10S	Precision	206	239/900CAME4	Spherical	90	1309	Ball Bearings	26	5304J	Ball Bearings	32
	60BTR10S	Precision	216	239/950CAME4	Spherical	90	1310	Ball Bearings	26	5304TNG	Ball Bearings	32
	60TAC120B	Precision	224	240/1000CAME4	Spherical	92	1311	Ball Bearings	26	5305J	Ball Bearings	32
	65BAR10S	Precision	214	240/1120CAME4	Spherical	92	1312	Ball Bearings	26	5305TNG	Ball Bearings	32
	65BNC10	Precision	202	240/1250CAME4	Spherical	92	1313	Ball Bearings	26	5306J	Ball Bearings	32
	65BNC10SN24	Precision	204	240/1320CAME4	Spherical	92	1314	Ball Bearings	26	5306TNG	Ball Bearings	32
	65BNR10H	Precision	208	240/1400CAME4	Spherical	92	1315	Ball Bearings	26	5307J	Ball Bearings	32
Rolling Mill Bearings	65BNR10S	Precision	206	240/500CAME4	Spherical	92	2200	Ball Bearings	28	5307TNG	Ball Bearings	32
	65BTR10S	Precision	216	240/530CAME4	Spherical	92	2201	Ball Bearings	28	5308J	Ball Bearings	32
	70BAR10S	Precision	214	240/560CAME4	Spherical	92	2202	Ball Bearings	28	5308TNG	Ball Bearings	32
	70BNC10	Precision	202	240/600CAME4	Spherical	92	2203	Ball Bearings	28	5309J	Ball Bearings	32
	70BNC10SN24	Precision	204	240/630CAME4	Spherical	92	2204	Ball Bearings	28	5309TNG	Ball Bearings	32
	70BNR10H	Precision	208	240/670CAME4	Spherical	92	2205	Ball Bearings	28	5310J	Ball Bearings	34
	70BNR10S	Precision	206	240/710CAME4	Spherical	92	2206	Ball Bearings	28	5310TNG	Ball Bearings	34
	70BTR10S	Precision	216	240/800CAME4	Spherical	92	2207	Ball Bearings	28	5311J	Ball Bearings	34
	75BAR10S	Precision	214	240/850CAME4	Spherical	92	2208	Ball Bearings	28	5311TNG	Ball Bearings	34
	75BNC10	Precision	202	240/900CAME4	Spherical	92	2209	Ball Bearings	28	531		

NSK NSK NSK NSK NSK NSK NSK NSK

Bearing No.			Bearing No.			Bearing No.			Bearing No.		
(prefix, no., Suffix)	Section	Page	(prefix, no., Suffix)	Section	Page	(prefix, no., Suffix)	Section	Page	(prefix, no., Suffix)	Section	Page
6015	Ball Bearings	14	6902	Ball Bearings	22	7205A5	Precision	196	7411B	Ball Bearings	40
6016	Ball Bearings	14	6903	Ball Bearings	22	7205B	Ball Bearings	36	7412B	Ball Bearings	40
6017	Ball Bearings	14	6904	Ball Bearings	22	7205C	Precision	194	7413B	Ball Bearings	40
6018	Ball Bearings	14	6905	Ball Bearings	22	7206A5	Precision	196	7414B	Ball Bearings	40
6019	Ball Bearings	14	6906	Ball Bearings	22	7206B	Ball Bearings	36	7415B	Ball Bearings	40
6020	Ball Bearings	14	6907	Ball Bearings	22	7206C	Precision	194	7416B	Ball Bearings	40
6021	Ball Bearings	14	6908	Ball Bearings	22	7207A5	Precision	196	7420B	Ball Bearings	40
6022	Ball Bearings	14	6909	Ball Bearings	22	7207B	Ball Bearings	36	7900A5	Precision	200
6024	Ball Bearings	14	6910	Ball Bearings	22	7207C	Precision	194	7900C	Precision	198
6026	Ball Bearings	14	6911	Ball Bearings	22	7208A5	Precision	196	7901A5	Precision	200
6028	Ball Bearings	14	6912	Ball Bearings	22	7208B	Ball Bearings	36	7901C	Precision	198
6030	Ball Bearings	14	6913	Ball Bearings	22	7208C	Precision	194	7902A5	Precision	200
6032	Ball Bearings	14	6914	Ball Bearings	22	7209A5	Precision	196	7902C	Precision	198
6034	Ball Bearings	14	6915	Ball Bearings	22	7209B	Ball Bearings	36	7903A5	Precision	200
6036	Ball Bearings	14	6916	Ball Bearings	22	7209C	Precision	194	7903C	Precision	198
6038	Ball Bearings	14	6917	Ball Bearings	22	7210A5	Precision	196	7904A5	Precision	200
6040	Ball Bearings	14	6918	Ball Bearings	22	7210B	Ball Bearings	36	7904C	Precision	198
6200	Ball Bearings	16	6919	Ball Bearings	22	7210C	Precision	194	7905A5	Precision	200
6201	Ball Bearings	16	6920	Ball Bearings	22	7211A5	Precision	196	7905C	Precision	198
6201-08	Ball Bearings	16	6921	Ball Bearings	22	7211B	Ball Bearings	36	7906A5	Precision	200
6201-13M	Ball Bearings	16	6922	Ball Bearings	22	7211C	Precision	194	7906C	Precision	198
6202	Ball Bearings	16	6924	Ball Bearings	22	7212A5	Precision	196	7907A5	Precision	200
6202-10	Ball Bearings	16	6926	Ball Bearings	22	7212B	Ball Bearings	36	7907C	Precision	198
6202-16M	Ball Bearings	16	6928	Ball Bearings	22	7212C	Precision	194	7908A5	Precision	200
6203	Ball Bearings	16	6930	Ball Bearings	22	7213A5	Precision	196	7908C	Precision	198
6203-625	Ball Bearings	16	6932	Ball Bearings	22	7213B	Ball Bearings	36	7909A5	Precision	200
6204	Ball Bearings	16	6934	Ball Bearings	22	7213C	Precision	194	7909C	Precision	198
6205	Ball Bearings	16	6936	Ball Bearings	22	7214A5	Precision	196	7910A5	Precision	200
6206	Ball Bearings	16	6938	Ball Bearings	22	7214B	Ball Bearings	36	7910C	Precision	198
6207	Ball Bearings	16	6940	Ball Bearings	22	7214C	Precision	194	7911A5	Precision	200
6208	Ball Bearings	16	7000A5	Precision	192	7215A5	Precision	196	7911C	Precision	198
6209	Ball Bearings	16	7000C	Precision	190	7215B	Ball Bearings	36	7912A5	Precision	200
6210	Ball Bearings	16	7001A5	Precision	192	7215C	Precision	194	7912C	Precision	198
6211	Ball Bearings	16	7001C	Precision	190	7216A5	Precision	196	7913A5	Precision	200
6212	Ball Bearings	16	7002A5	Precision	192	7216B	Ball Bearings	36	7913C	Precision	198
6213	Ball Bearings	16	7002C	Precision	190	7216C	Precision	194	7914A5	Precision	200
6214	Ball Bearings	16	7003A5	Precision	192	7217A5	Precision	196	7914C	Precision	198
6215	Ball Bearings	16	7003C	Precision	190	7217B	Ball Bearings	36	7915A5	Precision	200
6216	Ball Bearings	16	7004A5	Precision	192	7217C	Precision	194	7915C	Precision	198
6217	Ball Bearings	16	7004C	Precision	190	7218A5	Precision	196	7916A5	Precision	200
6218	Ball Bearings	16	7005A5	Precision	192	7218B	Ball Bearings	36	7916C	Precision	198
6219	Ball Bearings	16	7005C	Precision	190	7218C	Precision	194	7917A5	Precision	200
6220	Ball Bearings	16	7006A5	Precision	192	7219A5	Precision	196	7917C	Precision	198
6221	Ball Bearings	16	7006C	Precision	190	7219B	Ball Bearings	36	7918A5	Precision	200
6222	Ball Bearings	16	7007A5	Precision	192	7219C	Precision	194	7918C	Precision	198
6224	Ball Bearings	16	7007C	Precision	190	7220A5	Precision	196	7919A5	Precision	200
6226	Ball Bearings	16	7008A5	Precision	192	7220B	Ball Bearings	36	7919C	Precision	198
6228	Ball Bearings	16	7008C	Precision	190	7220C	Precision	194	7920A5	Precision	200
6230	Ball Bearings	16	7009A5	Precision	192	7221A5	Precision	196	7920C	Precision	198
6232	Ball Bearings	16	7009C	Precision	190	7221B	Ball Bearings	36	7921A5	Precision	200
6234	Ball Bearings	16	7010A5	Precision	192	7221C	Precision	194	7921C	Precision	198
6236	Ball Bearings	16	7010C	Precision	190	7222A5	Precision	196	7922A5	Precision	200
6238	Ball Bearings	16	7011A5	Precision	192	7222B	Ball Bearings	36	7922C	Precision	198
6300	Ball Bearings	18	7011C	Precision	190	7222C	Precision	194	7924A5	Precision	200
6301	Ball Bearings	18	7012A5	Precision	192	7224A5	Precision	196	7924C	Precision	198
6302	Ball Bearings	18	7012C	Precision	190	7224B	Ball Bearings	36	7926A5	Precision	200
6303	Ball Bearings	18	7013A5	Precision	192	7224C	Precision	194	7926C	Precision	198
6304	Ball Bearings	18	7013C	Precision	190	7226A5	Precision	196	7928A5	Precision	200
6305	Ball Bearings	18	7014A5	Precision	192	7226B	Ball Bearings	36	7928C	Precision	198
6306	Ball Bearings	18	7014C	Precision	190	7226C	Precision	194	7930A5	Precision	200
6307	Ball Bearings	18	7015A5	Precision	192	7228A5	Precision	196	7930C	Precision	198
6308	Ball Bearings	18	7015C	Precision	190	7228B	Ball Bearings	36	7932A5	Precision	200
6309	Ball Bearings	18	7016A5	Precision	192	7228C	Precision	194	7932C	Precision	198
6310	Ball Bearings	18	7016C	Precision	190	7230A5	Precision	196	7934A5	Precision	200
6311	Ball Bearings	18	7017A5	Precision	192	7230B	Ball Bearings	36	7934C	Precision	198
6312	Ball Bearings	18	7017C	Precision	190	7230C	Precision	194	7936A5	Precision	200
6313	Ball Bearings	18	7018A5	Precision	192	7232A5	Precision	196	7936C	Precision	198
6314	Ball Bearings	18	7018C	Precision	190	7232B	Ball Bearings	36	7938A5	Precision	200
6315	Ball Bearings	18	7019A5	Precision	192	7232C	Precision	194	7938C	Precision	198
6316	Ball Bearings	18	7019C	Precision	190	7234A5	Precision	196	7940A5	Precision	200
6317	Ball Bearings	18	7020A5	Precision	192	7234B	Ball Bearings	36	7940C	Precision	198
6318	Ball Bearings	18	7020C	Precision	190	7234C	Precision	194	09067	Tapered	132
6319	Ball Bearings	18	7021A5	Precision	192	7236A5	Precision	196	09067	Tapered	132
6320	Ball Bearings	18	7021C	Precision	190	7236B	Ball Bearings	36	09074	Tapered	132
6321	Ball Bearings	18	7022A5	Precision	192	7236C	Precision	194	09078	Tapered	132
6322	Ball Bearings	18	7022C	Precision	190	7238A5	Precision	196	09194	Tapered	132
6324	Ball Bearings	18	7024A5	Precision	192	7238B	Ball Bearings	36	09195	Tapered	132
6326	Ball Bearings	18	7024C	Precision	190	7238C	Precision	194	09195	Tapered	132
6328	Ball Bearings	18	7026A5	Precision	192	7240A5	Precision	196	09196	Tapered	132
6330	Ball Bearings	18	7026C	Precision	190	7240B	Ball Bearings	36	11520	Tapered	132
6332	Ball Bearings	18	7028A5	Precision	192	7240C	Precision	194	11590	Tapered	132
6334	Ball Bearings	18	7028C	Precision	190	7300B	Ball Bearings	38	14123A	Tapered	134
6336	Ball Bearings	18	7030A5	Precision	192	7301B	Ball Bearings	38	14125A	Tapered	134
6338	Ball Bearings	18	7030C	Precision	190	7302B	Ball Bearings	38	14130	Tapered	134
6340	Ball Bearings	18	7032A5	Precision	192	7303B	Ball Bearings	38	14136A	Tapered	134
6800	Ball Bearings	20	7032C	Precision	190	7304B	Ball Bearings	38	14137A	Tapered	134
6801	Ball Bearings	20	7034A5	Precision	192	7305B	Ball Bearings	38	14138A	Tapered	134
6802	Ball Bearings	20	7034C	Precision	190	7306B	Ball Bearings	38	14274	Tapered	134
6803	Ball Bearings	20	7036A5	Precision	192	7307B	Ball Bearings	38	14274	Tapered	134
6804	Ball Bearings	20	7036C	Precision	190	7308B	Ball Bearings	38	14276	Tapered	134
6805	Ball Bearings	20	7038A5	Precision	192	7309B	Ball Bearings	38	14276	Tapered	134
6806	Ball Bearings	20	7038C	Precision	190	7310B	Ball Bearings	38	14276	Tapered	134
6807	Ball Bearings	20	7040A5	Precision	192	7311B	Ball Bearings	38	14276	Tapered	134
6808	Ball Bearings	20	7040C	Precision	190	7312B	Ball Bearings	38	15100	Tapered	132
6809	Ball Bearings	20	07087	Tapered	132	7313B	Ball Bearings	38	15101	Tapered	132
6810	Ball Bearings	20	07097	Tapered	132	7314B	Ball Bearings	38	15117	Tapered	132
6811	Ball Bearings	20	07097	Tapered	132	7315B	Ball Bearings	38	15117	Tapered	132
6812	Ball Bearings	20	07098	Tapered	132	7316B	Ball Bearings	38	15118	Tapered	132
6813	Ball Bearings	20	07100	Tapered	132	7317B	Ball Bearings	38	15123	Tapered	134
6814	Ball Bearings	20	07196	Tapered	132	7318B	Ball Bearings	38	15125	Tapered	134
6815	Ball Bearings	20	07196	Tapered	132	7319B	Ball Bearings	38	15126	Tapered	134
6816	Ball Bearings	20	07198	Tapered	132	7320B	Ball Bearings	38	15126	Tapered	134
6817	Ball Bearings	20	7200A5	Precision	196	7321B	Ball Bearings	38	15245	Tapered	132
6818	Ball Bearings	20	7200B	Ball Bearings	36	7322B	Ball Bearings	38	15245	Tapered	132
6819	Ball Bearings	20	7200C	Precision	194	7324B	Ball Bearings	38	15245	Tapered	132
6820	Ball Bearings	20	7201A5	Precision	196	7326B	Ball Bearings	38	15245	Tapered	134
6821	Ball Bearings	20	7201B	Ball Bearings	36	7328B	Ball Bearings	38	15245	Tapered	134
6822	Ball Bearings	20	7201C	Precision	194	7330B	Ball Bearings	38	15245	Tapered	134
6824	Ball Bearings	20	7202A5	Precision	196	7332B	Ball Bearings	38	15250	Tapered	132
6826	Ball Bearings	20	7202B	Ball Bearings	36	7334B	Ball Bearings	38	15250	Tapered	134
6828	Ball Bearings	20	7202C	Precision	194	7336B	Ball Bearings	38	15250X	Tapered	132
6830	Ball Bearings	20	7203A5	Precision	196	7338B	Ball Bearings	38	18520	Tapered	134
6832	Ball Bearings	20	7203B	Ball Bearings	36	7340B	Ball Bearings	38	18590	Tapered	134
6834	Ball Bearings	20	7203C	Precision	194	7405B	Ball Bearings	40	18620	Tapered	136
6836	Ball Bearings	20	07204	Tapered	132	7406B	Ball Bearings	40	18690	Tapered	136
6838	Ball Bearings	20	07204	Tapered	132	7407B	Ball Bearings	40	22206CE4	Spherical	70
6840	Ball Bearings	20	7204A5	Precision	196	7408B	Ball Bearings	40	22206HE4	Spherical	70
6900	Ball Bearings	22	7204B	Ball Bearings	36	7409B	Ball Bearings	40	22207CE4	Spherical	70
6901	Ball Bearings	22	7204C	Precision	194	7410B	Ball Bearings	40	22207HE4	Spherical	70

Introduction
Ball Bearings
Cylindrical Roller Bearings
Spherical Roller Bearings
Tapered Roller Bearings
Thrust Bearings
Split Pillow Blocks

NSK NSK NSK NSK NSK NSK NSK NSK

	Bearing No. (prefix, no., Suffix)			Bearing No. (prefix, no., Suffix)			Bearing No. (prefix, no., Suffix)			Bearing No. (prefix, no., Suffix)		
	Section	Page	Section	Page	Section	Page	Section	Page	Section	Page	Page	
Introduction	22208CDE4	Spherical	70	22322HE4	Spherical	76	23234CE4	Spherical	86	24176CXE4	Spherical	94
	22208HE4	Spherical	70	22324GAME4	Spherical	76	23236CAME4	Spherical	86	24180CAME4	Spherical	94
	22209CDE4	Spherical	70	22324GAME4C(4)U15-VS	Spherical	96	23236CE4	Spherical	86	24184CAME4	Spherical	94
	22209HE4	Spherical	70	22324EA4	Spherical	76	23238CAME4	Spherical	86	24188CAME4	Spherical	94
	22210CAME4	Spherical	70	22326CAME4	Spherical	76	23238CE4	Spherical	86	24192CAME4	Spherical	94
	22210EA4	Spherical	70	22326GAME4C(4)U15-VS	Spherical	96	23240CAME4	Spherical	86	24196CAME4	Spherical	94
	22210HE4	Spherical	70	22326CE4	Spherical	76	23240CE4	Spherical	86	25520	Tapered	134
	22211CAME4	Spherical	70	22328CAME4	Spherical	76	23244CAME4	Spherical	86	25520	Tapered	136
	22211EA4	Spherical	70	22328GAME4C(4)U15-VS	Spherical	96	23244CE4	Spherical	86	25523	Tapered	134
	22211HE4	Spherical	70	22328CE4	Spherical	76	23248CAME4	Spherical	86	25523	Tapered	136
	22212CAME4	Spherical	70	22330CAME4	Spherical	76	23252CAME4	Spherical	86	25577	Tapered	134
	22212EA4	Spherical	70	22330GAME4C(4)U15-VS	Spherical	96	23256	Tapered	132	25580	Tapered	134
Ball Bearings	22212HE4	Spherical	70	22332CAME4	Spherical	76	23256CAME4	Spherical	86	25590	Tapered	136
	22213CAME4	Spherical	70	22332GAME4C(4)U15-VS	Spherical	96	23260CAME4	Spherical	88	25590	Tapered	136
	22213EA4	Spherical	70	22334CAME4	Spherical	76	23264CAME4	Spherical	88	25821	Tapered	134
	22213HE4	Spherical	70	22334GAME4C(4)U15-VS	Spherical	96	23268CAME4	Spherical	88	25877	Tapered	134
	22214CAME4	Spherical	70	22336CAME4	Spherical	76	23272CAME4	Spherical	88	26822	Tapered	134
	22214EA4	Spherical	70	22336GAME4C(4)U15-VS	Spherical	96	23276CAME4	Spherical	88	26882	Tapered	134
	22214HE4	Spherical	70	22338CAME4	Spherical	76	23280CAME4	Spherical	88	29240	Thrust	149
	22215CAME4	Spherical	70	22338GAME4C(4)U15-VS	Spherical	96	23284CAME4	Spherical	88	29240	Thrust	150
	22215EA4	Spherical	70	22340CAME4	Spherical	76	23288CAME4	Spherical	88	29244	Thrust	150
	22215HE4	Spherical	70	22340GAME4C(4)U15-VS	Spherical	96	23292CAME4	Spherical	88	29248	Thrust	150
	22216CAME4	Spherical	70	22344CAME4	Spherical	76	23296CAME4	Spherical	88	29252	Thrust	150
	22216EA4	Spherical	70	22348CAME4	Spherical	76	23326GAME4C(4)U15-VS	Spherical	96	29256	Thrust	150
Cylindrical Roller Bearings	22216HE4	Spherical	70	22352CAME4	Spherical	76	23330CAME4C(4)U15-VS	Spherical	96	29260	Thrust	150
	22217CAME4	Spherical	70	22356CAME4	Spherical	76	23332CAME4C(4)U15-VS	Spherical	96	29264	Thrust	150
	22217EA4	Spherical	70	22360CAME4	Spherical	76	23326CAME4	Spherical	90	29268	Thrust	150
	22217HE4	Spherical	70	22364CAME4	Spherical	76	23332CAME4	Spherical	90	29272	Thrust	150
	22218CAME4	Spherical	70	23020CDE4	Spherical	78	23338CAME4	Spherical	90	29276	Thrust	152
	22218EA4	Spherical	70	23022CAME4	Spherical	78	23348CAME4	Spherical	90	29276	Thrust	152
	22218HE4	Spherical	70	23022CDE4	Spherical	78	23396CAME4	Spherical	90	29280	Thrust	152
	22219CAME4	Spherical	72	23024CAME4	Spherical	78	23398CAME4	Spherical	90	29284	Thrust	152
	22219EA4	Spherical	72	23024CDE4	Spherical	78	23940CAME4	Spherical	90	29288	Thrust	152
	22219HE4	Spherical	72	23026CAME4	Spherical	78	23944CAME4	Spherical	90	29292	Thrust	152
	22220CAME4	Spherical	72	23026CDE4	Spherical	78	23948CAME4	Spherical	90	29296	Thrust	152
	22220EA4	Spherical	72	23028CAME4	Spherical	78	23952CAME4	Spherical	90	29317E	Thrust	148
Spherical Roller Bearings	22220HE4	Spherical	72	23028CDE4	Spherical	78	23956CAME4	Spherical	90	29318E	Thrust	148
	22222CAME4	Spherical	72	23030CAME4	Spherical	78	23960CAME4	Spherical	90	29320E	Thrust	148
	22222EA4	Spherical	72	23030CDE4	Spherical	78	23964CAME4	Spherical	90	29322E	Thrust	148
	22222HE4	Spherical	72	23032CAME4	Spherical	78	23968CAME4	Spherical	90	29324E	Thrust	148
	22224CAME4	Spherical	72	23032CDE4	Spherical	78	23972CAME4	Spherical	90	29326E	Thrust	148
	22224EA4	Spherical	72	23034CAME4	Spherical	78	23976CAME4	Spherical	90	29328E	Thrust	148
	22224HE4	Spherical	72	23034CDE4	Spherical	78	23980CAME4	Spherical	90	29330E	Thrust	148
	22226CAME4	Spherical	72	23036CAME4	Spherical	78	23984CAME4	Spherical	90	29332E	Thrust	148
	22226EA4	Spherical	72	23036CDE4	Spherical	78	23988CAME4	Spherical	90	29334E	Thrust	148
	22226HE4	Spherical	72	23038CAME4	Spherical	78	23992CAME4	Spherical	90	29336E	Thrust	148
	22228CAME4	Spherical	72	23040CAME4	Spherical	78	23996CAME4	Spherical	90	29338E	Thrust	148
	22228CDE4	Spherical	72	23044CAME4	Spherical	78	24020CE4	Spherical	92	29340E	Thrust	149
Tapered Roller Bearings	22230CAME4	Spherical	72	23048CAME4	Spherical	78	24022CE4	Spherical	92	29340H	Thrust	150
	22230CDE4	Spherical	72	23052CAME4	Spherical	78	24024CAME4	Spherical	92	29344	Thrust	150
	22232CAME4	Spherical	72	23056CAME4	Spherical	78	24024CE4	Spherical	92	29348	Thrust	150
	22232CDE4	Spherical	72	23064CAME4	Spherical	78	24026CAME4	Spherical	92	29352	Thrust	150
	22234CAME4	Spherical	72	23068CAME4	Spherical	78	24026CE4	Spherical	92	29356	Thrust	150
	22234CDE4	Spherical	72	23072CAME4	Spherical	78	24028CAME4	Spherical	92	29360	Thrust	150
	22236CAME4	Spherical	72	23076CAME4	Spherical	78	24028CE4	Spherical	92	29364	Thrust	150
	22236CDE4	Spherical	72	23080CAME4	Spherical	78	24030CAME4	Spherical	92	29368	Thrust	150
	22238CAME4	Spherical	72	23084CAME4	Spherical	78	24030CE4	Spherical	92	29372	Thrust	150
	22240CAME4	Spherical	72	23088CAME4	Spherical	78	24032CAME4	Spherical	92	29376	Thrust	152
	22244CAME4	Spherical	72	23092CAME4	Spherical	78	24032CE4	Spherical	92	29380	Thrust	152
	22248CAME4	Spherical	72	23096CAME4	Spherical	78	24034CAME4	Spherical	92	29384	Thrust	152
Thrust Bearings	22252CAME4	Spherical	72	23100	Tapered	132	24034CE4	Spherical	92	29388	Thrust	152
	22256CAME4	Spherical	72	23120CAME4	Spherical	82	24036CAME4	Spherical	92	29392	Thrust	152
	22260CAME4	Spherical	72	23120CE4	Spherical	82	24036CE4	Spherical	92	29396	Thrust	152
	22264CAME4	Spherical	72	23122CAME4	Spherical	82	24038CAME4	Spherical	92	29412E	Thrust	148
	22308CAME4	Spherical	74	23122CE4	Spherical	82	24038CE4	Spherical	92	29413E	Thrust	148
	22308GAME4C(4)U15-VS	Spherical	96	23124CAME4	Spherical	82	24040CAME4	Spherical	92	29414E	Thrust	148
	22308CDE4	Spherical	74	23124CE4	Spherical	82	24040CE4	Spherical	92	29415E	Thrust	148
	22309CAME4	Spherical	74	23126CAME4	Spherical	82	24044CAME4	Spherical	92	29417E	Thrust	148
	22309GAME4C(4)U15-VS	Spherical	96	23126CE4	Spherical	82	24048CAME4	Spherical	92	29418E	Thrust	148
	22309CDE4	Spherical	74	23128CAME4	Spherical	82	24048CE4	Spherical	92	29418E	Thrust	148
	22309HE4	Spherical	74	23128CE4	Spherical	82	24052CAME4	Spherical	92	29420E	Thrust	148
	22310CAME4	Spherical	74	23130CAME4	Spherical	82	24056CAME4	Spherical	92	29422E	Thrust	148
Split Pillow Blocks	22310CAME4C(4)U15-VS	Spherical	96	23130CE4	Spherical	82	24060CAME4	Spherical	92	29424E	Thrust	148
	22310EA4	Spherical	74	23132CAME4	Spherical	82	24064CAME4	Spherical	92	29426E	Thrust	148
	22310HE4	Spherical	74	23132CE4	Spherical	82	24068CAME4	Spherical	92	29428E	Thrust	148
	22311CAME4	Spherical	74	23134CAME4	Spherical	82	24072CAME4	Spherical	92	29430E	Thrust	148
	22311CAME4C(4)U15-VS	Spherical	96	23134CE4	Spherical	82	24076CAME4	Spherical	92	29432E	Thrust	148
	22311EA4	Spherical	74	23136CAME4	Spherical	82	24080CAME4	Spherical	92	29434	Thrust	148
	22311HE4	Spherical	74	23136CE4	Spherical	82	24084CAME4	Spherical	92	29436	Thrust	148
	22312CAME4	Spherical	74	23138CAME4	Spherical	82	24088CAME4	Spherical	92	29438	Thrust	148
	22312CAME4C(4)U15-VS	Spherical	96	23138CE4	Spherical	82	24092CAME4	Spherical	92	29440	Thrust	148
	22312EA4	Spherical	74	23140CAME4	Spherical	82	24096CAME4	Spherical	92	29444	Thrust	150
	22312HE4	Spherical	74	23140CE4	Spherical	82	24120CAME4	Spherical	94	29448	Thrust	150
	22313CAME4	Spherical	74	23144CAME4	Spherical	82	24122CAME4	Spherical	94	29452	Thrust	150
Super Precision Bearings	22313CAME4C(4)U15-VS	Spherical	96	23144CE4	Spherical	82	24122CE4	Spherical	94	29456	Thrust	150
	22313EA4	Spherical	74	23148CAME4	Spherical	82	24124CAME4	Spherical	94	29460	Thrust	150
	22313HE4	Spherical	74	23148CE4	Spherical	82	24124CE4	Spherical	94	29464	Thrust	150
	22314CAME4	Spherical	74	23152CAME4	Spherical	82	24126CAME4	Spherical	94	29468	Thrust	150
	22314CAME4C(4)U15-VS	Spherical	96	23156CAME4	Spherical	82	24126CE4	Spherical	94	29472	Thrust	150
	22314EA4	Spherical	74	23160CAME4	Spherical	82	24128CAME4	Spherical	94	29476	Thrust	152
	22314HE4	Spherical	74	23164CAME4	Spherical	82	24128CE4	Spherical	94	29480	Thrust	152
	22315CAME4	Spherical	74	23168CAME4	Spherical	82	24130CAME4	Spherical	94	29484	Thrust	152
	22315CAME4C(4)U15-VS	Spherical	96	23172CAME4	Spherical	82	24130CE4	Spherical	94	29488	Thrust	152
	22315EA4	Spherical	74	23176CAME4	Spherical	82	24132CAME4	Spherical	94	29492	Thrust	152
	22315HE4	Spherical	74	23180CAME4	Spherical	84	24132CE4	Spherical	94	29496	Thrust	152
	22316CAME4	Spherical	74	23184CAME4	Spherical	84	24134CAME4	Spherical	94	30216C	Tapered	124
Linear Motion Bearings	22316CAME4C(4)U15-VS	Spherical	96	23188CAME4	Spherical	84	24134CE4	Spherical	94	30217C	Tapered	124
	22316EA4	Spherical	74									

NSK NSK NSK NSK NSK NSK NSK NSK NSK

Bearing No. (prefix, no., Suffix)	Section	Page	Bearing No. (prefix, no., Suffix)	Section	Page	Bearing No. (prefix, no., Suffix)	Section	Page	Bearing No. (prefix, no., Suffix)	Section	Page
30344	Tapered	106	51420X	Thrust	146	HR30207C	Tapered	124	HR322/32	Tapered	112
30348	Tapered	106	51422X	Thrust	146	HR30207J	Tapered	104	HR32203J	Tapered	104
30352	Tapered	106	51424X	Thrust	146	HR30208C	Tapered	124	HR32204J	Tapered	112
32248	Tapered	112	51426X	Thrust	146	HR30208J	Tapered	104	HR32205J	Tapered	112
32252	Tapered	112	51428X	Thrust	146	HR30209C	Tapered	124	HR32206J	Tapered	112
32256	Tapered	112	51430X	Thrust	146	HR30209J	Tapered	104	HR32207J	Tapered	112
32260	Tapered	112	51432X	Thrust	146	HR30210C	Tapered	124	HR32208J	Tapered	112
32264	Tapered	112	63204DDU	Ball Bearings	24	HR30210J	Tapered	104	HR32209J	Tapered	112
32303	Tapered	114	63205DDU	Ball Bearings	24	HR30211J	Tapered	104	HR32210J	Tapered	112
32312C	Tapered	130	63206DDU	Ball Bearings	24	HR30212J	Tapered	104	HR32211J	Tapered	112
32314C	Tapered	130	63207DDU	Ball Bearings	24	HR30213J	Tapered	104	HR32212J	Tapered	112
32315C	Tapered	130	63208DDU	Ball Bearings	24	HR30214J	Tapered	104	HR32213J	Tapered	112
32326	Tapered	114	63209DDU	Ball Bearings	24	HR30215J	Tapered	104	HR32214J	Tapered	112
32328	Tapered	114	63310DDU	Ball Bearings	25	HR30216J	Tapered	104	HR32215J	Tapered	112
32330	Tapered	114	63311DDU	Ball Bearings	25	HR30217J	Tapered	104	HR32216J	Tapered	112
32332	Tapered	114	63312DDU	Ball Bearings	25	HR30218J	Tapered	104	HR32217J	Tapered	112
32334	Tapered	114	885117	Ball Bearings	45	HR30219J	Tapered	104	HR32218J	Tapered	112
32336	Tapered	114	885118	Ball Bearings	45	HR30220J	Tapered	104	HR32219J	Tapered	112
32340	Tapered	114	885586	Ball Bearings	45	HR30221J	Tapered	104	HR32220J	Tapered	112
32344	Tapered	114	885801	Ball Bearings	45	HR30222J	Tapered	104	HR32221J	Tapered	112
32348	Tapered	114	885801SE	Ball Bearings	45	HR30224J	Tapered	104	HR32222J	Tapered	112
32364	Tapered	116	885807C	Ball Bearings	45	HR30226J	Tapered	104	HR32224J	Tapered	112
32976	Tapered	116	885820	Ball Bearings	45	HR30228J	Tapered	104	HR32226J	Tapered	112
32980	Tapered	116	A4050	Tapered	132	HR303/22	Tapered	106	HR32228J	Tapered	112
33287	Tapered	136	A4059	Tapered	132	HR303/22C	Tapered	126	HR32230J	Tapered	112
33462	Tapered	136	A4138	Tapered	132	HR303/28	Tapered	106	HR32232J	Tapered	112
39520	Tapered	136	A4138	Tapered	132	HR303/28C	Tapered	126	HR32234J	Tapered	112
39520	Tapered	136	A6062	Tapered	132	HR303/32	Tapered	106	HR32236J	Tapered	112
39585	Tapered	136	A6067	Tapered	132	HR303/32C	Tapered	126	HR32238J	Tapered	112
39590	Tapered	136	A6075	Tapered	132	HR30302J	Tapered	106	HR32240J	Tapered	112
47620	Tapered	136	A6157	Tapered	132	HR30303J	Tapered	106	HR32244J	Tapered	112
47686	Tapered	136	A6157	Tapered	132	HR30304C	Tapered	126	HR323/28C	Tapered	130
51100	Thrust	142	A6157	Tapered	132	HR30304J	Tapered	106	HR323/32C	Tapered	130
51101	Thrust	142	A7420B	Ball Bearings	40	HR30305C	Tapered	126	HR32304C	Tapered	130
51102	Thrust	142	A99202-08A	Ball Bearings	44	HR30305J	Tapered	106	HR32304J	Tapered	114
51103	Thrust	142	AN15	Split Block	181	HR30306C	Tapered	126	HR32305C	Tapered	130
51104	Thrust	142	AN16	Split Block	181	HR30306J	Tapered	106	HR32305J	Tapered	114
51105	Thrust	142	AN17	Split Block	181	HR30307C	Tapered	126	HR32306C	Tapered	130
51106	Thrust	142	AN18	Split Block	181	HR30307J	Tapered	106	HR32306J	Tapered	114
51107	Thrust	142	AN19	Split Block	181	HR30308C	Tapered	126	HR32307C	Tapered	130
51108	Thrust	142	AN20	Split Block	181	HR30308J	Tapered	106	HR32307J	Tapered	114
51109	Thrust	142	AN21	Split Block	181	HR30309C	Tapered	126	HR32308C	Tapered	130
51110	Thrust	144	AN22	Split Block	181	HR30309J	Tapered	106	HR32308J	Tapered	114
51111	Thrust	144	AN24	Split Block	181	HR30310C	Tapered	126	HR32309C	Tapered	130
51112	Thrust	144	AN26	Split Block	181	HR30310J	Tapered	106	HR32309J	Tapered	114
51113	Thrust	144	AN28	Split Block	181	HR30311J	Tapered	106	HR32310C	Tapered	130
51114	Thrust	144	AN30	Split Block	181	HR30312J	Tapered	106	HR32310J	Tapered	114
51115	Thrust	144	AN32	Split Block	181	HR30313J	Tapered	106	HR32311J	Tapered	114
51116	Thrust	144	AN34	Split Block	181	HR30314J	Tapered	106	HR32312J	Tapered	114
51117	Thrust	144	AN36	Split Block	181	HR30315J	Tapered	106	HR32313J	Tapered	114
51118	Thrust	146	AN38	Split Block	181	HR30316J	Tapered	106	HR32314J	Tapered	114
51120	Thrust	146	AN40	Split Block	181	HR30317J	Tapered	106	HR32315J	Tapered	114
51122	Thrust	146	BL205	Ball Bearings	42	HR30318J	Tapered	106	HR32316J	Tapered	114
51124	Thrust	146	BL206	Ball Bearings	42	HR30319J	Tapered	106	HR32317J	Tapered	114
51126	Thrust	146	BL207	Ball Bearings	42	HR30320J	Tapered	106	HR32318J	Tapered	114
51128X	Thrust	146	BL208	Ball Bearings	42	HR30321J	Tapered	106	HR32319J	Tapered	114
51130X	Thrust	146	BL209	Ball Bearings	42	HR30322J	Tapered	106	HR32320J	Tapered	114
51132X	Thrust	146	BL210	Ball Bearings	42	HR30324J	Tapered	106	HR32321J	Tapered	114
51200	Thrust	142	BL211	Ball Bearings	42	HR31305J	Tapered	108	HR32322J	Tapered	114
51201	Thrust	142	BL212	Ball Bearings	42	HR31306J	Tapered	108	HR32324J	Tapered	114
51202	Thrust	142	BL213	Ball Bearings	42	HR31307J	Tapered	108	HR32306J	Tapered	116
51203	Thrust	142	BL214	Ball Bearings	42	HR31308J	Tapered	108	HR32907J	Tapered	116
51204	Thrust	142	BL215	Ball Bearings	42	HR31309J	Tapered	108	HR32908J	Tapered	116
51205	Thrust	142	BL216	Ball Bearings	42	HR31310J	Tapered	108	HR32909J	Tapered	116
51206	Thrust	142	BL217	Ball Bearings	42	HR31311J	Tapered	108	HR32910J	Tapered	116
51207	Thrust	142	BL218	Ball Bearings	42	HR31312J	Tapered	108	HR32911J	Tapered	116
51208	Thrust	142	BL219	Ball Bearings	42	HR31313J	Tapered	108	HR32912J	Tapered	116
51209	Thrust	142	BL220	Ball Bearings	42	HR31314J	Tapered	108	HR32913J	Tapered	116
51210	Thrust	144	BL221	Ball Bearings	42	HR31315J	Tapered	108	HR32914J	Tapered	116
51211	Thrust	144	BL305	Ball Bearings	42	HR31316J	Tapered	108	HR32915J	Tapered	116
51212	Thrust	144	BL306	Ball Bearings	42	HR31317J	Tapered	108	HR32916J	Tapered	116
51213	Thrust	144	BL307	Ball Bearings	42	HR31318J	Tapered	108	HR32917J	Tapered	116
51214	Thrust	144	BL308	Ball Bearings	42	HR31319J	Tapered	108	HR32918J	Tapered	116
51215	Thrust	144	BL309	Ball Bearings	42	HR31320J	Tapered	108	HR32919J	Tapered	116
51216	Thrust	144	BL310	Ball Bearings	42	HR31321J	Tapered	108	HR32920J	Tapered	116
51217	Thrust	144	BL311	Ball Bearings	42	HR31322J	Tapered	108	HR32921J	Tapered	116
51218	Thrust	146	BL312	Ball Bearings	42	HR31324J	Tapered	108	HR32922J	Tapered	116
51220	Thrust	146	BL313	Ball Bearings	42	HR31326J	Tapered	108	HR32924J	Tapered	116
51222	Thrust	146	BL314	Ball Bearings	42	HR31328J	Tapered	108	HR32926J	Tapered	116
51224	Thrust	146	BL315	Ball Bearings	42	HR31330J	Tapered	108	HR32928J	Tapered	116
51226X	Thrust	146	BL316	Ball Bearings	42	HR320/22XJ	Tapered	110	HR32930J	Tapered	116
51228X	Thrust	146	BL317	Ball Bearings	42	HR320/28XJ	Tapered	110	HR32932J	Tapered	116
51230X	Thrust	146	BL318	Ball Bearings	42	HR320/32XJ	Tapered	110	HR32934J	Tapered	116
51232X	Thrust	146	BL319	Ball Bearings	42	HR32004XJ	Tapered	110	HR32936J	Tapered	116
51305	Thrust	142	FSAF216	Split Block	160	HR32005XJ	Tapered	110	HR32938J	Tapered	116
51306	Thrust	142	FSAF217	Split Block	160	HR32006XJ	Tapered	110	HR32940J	Tapered	116
51307	Thrust	142	FSAF218	Split Block	160	HR32007XJ	Tapered	110	HR32944J	Tapered	116
51308	Thrust	142	FSAF220	Split Block	160	HR32008XJ	Tapered	110	HR32948J	Tapered	116
51309	Thrust	142	FSAF311	Split Block	162	HR32009XJ	Tapered	110	HR32952J	Tapered	116
51310	Thrust	144	FSAF313	Split Block	162	HR32010XJ	Tapered	110	HR32956J	Tapered	116
51311	Thrust	144	FSAF315	Split Block	162	HR32011XJ	Tapered	110	HR32960J	Tapered	116
51312	Thrust	144	FSAF316	Split Block	162	HR32012XJ	Tapered	110	HR32968J	Tapered	116
51313	Thrust	144	FSAF317	Split Block	162	HR32013XJ	Tapered	110	HR32972J	Tapered	116
51314	Thrust	144	FSAF513	Split Block	164	HR32014XJ	Tapered	110	HR33005J	Tapered	118
51315	Thrust	144	FSAF515	Split Block	164	HR32015XJ	Tapered	110	HR33006J	Tapered	118
51316	Thrust	144	FSAF516	Split Block	164	HR32016XJ	Tapered	110	HR33007J	Tapered	118
51317	Thrust	144	FSAF517	Split Block	164	HR32017XJ	Tapered	110	HR33008J	Tapered	118
51318	Thrust	146	FSAF518	Split Block	164	HR32018XJ	Tapered	110	HR33009J	Tapered	118
51320	Thrust	146	FSAF520	Split Block	164	HR32019XJ	Tapered	110	HR33010J	Tapered	118
51322X	Thrust	146	FSAF611	Split Block	166	HR32020XJ	Tapered	110	HR33011J	Tapered	118
51324X	Thrust	146	FSAF613	Split Block	166	HR32021XJ	Tapered	110	HR33012J	Tapered	118
51326X	Thrust	146	FSAF615	Split Block	166	HR32022XJ	Tapered	110	HR33013J	Tapered	118
51328X	Thrust	146	FSAF616	Split Block	166	HR32024XJ	Tapered	110	HR33014J	Tapered	118
51330X	Thrust	146	FSAF617	Split Block	166	HR32026XJ	Tapered	110	HR33015J	Tapered	118
51332X	Thrust	146	HM212047	Tapered	136	HR32028XJ	Tapered	110	HR33016J	Tapered	118
51405	Thrust	142	HM89410	Tapered	134	HR32030XJ	Tapered	110	HR33017J	Tapered	118
51407	Thrust	142	HM89449	Tapered	134	HR32032XJ	Tapered	110	HR33018J	Tapered	118
51408	Thrust	142	HR302/22C	Tapered	124	HR32034XJ	Tapered	110	HR33019J	Tapered	118
51409	Thrust	142	HR302/28C	Tapered	124	HR32036XJ	Tapered	110	HR33020J	Tapered	118
51410	Thrust	144	HR302/32C	Tapered	124	HR32038XJ	Tapered	110	HR33021J	Tapered	118
51411	Thrust	144	HR30202	Tapered	104	HR32040XJ	Tapered	110	HR33022J	Tapered	118
51412	Thrust	144	HR30203J	Tapered	104	HR32042XJ	Tapered				

NSK NSK NSK NSK NSK NSK NSK NSK NSK

	Bearing No. (prefix, no., Suffix)			Section			Page					
Introduction	HR33116J	Tapered	120	LAH35EL/FLZ	Linear	238	N,NU,NJ211	Cylindrical	52	N,NU,NJ414	Cylindrical	56
	HR33117J	Tapered	120	LAH35EM/EMZ	Linear	240	N,NU,NJ212	Cylindrical	52	N,NU,NJ415	Cylindrical	56
	HR33118J	Tapered	120	LAH35GL/HLZ	Linear	238	N,NU,NJ213	Cylindrical	52	N,NU,NJ416	Cylindrical	56
	HR33120J	Tapered	120	LAH35GM/GMZ	Linear	240	N,NU,NJ214	Cylindrical	52	N,NU,NJ417	Cylindrical	56
	HR33122J	Tapered	120	LAH45	Linear	263	N,NU,NJ215	Cylindrical	52	N,NU,NJ418	Cylindrical	56
	HR33205J	Tapered	122	LAH45AN/ANZ	Linear	236	N,NU,NJ216	Cylindrical	52	N,NU,NJ419	Cylindrical	56
	HR33206J	Tapered	122	LAH45BN/BNZ	Linear	236	N,NU,NJ217	Cylindrical	52	N,NU,NJ420	Cylindrical	56
	HR33207J	Tapered	122	LAH45EL/FLZ	Linear	238	N,NU,NJ218	Cylindrical	52	N,NU,NJ421	Cylindrical	56
	HR33208J	Tapered	122	LAH45EM/EMZ	Linear	240	N,NU,NJ219	Cylindrical	52	N,NU,NJ422	Cylindrical	56
	HR33209J	Tapered	122	LAH45GL/HLZ	Linear	238	N,NU,NJ220	Cylindrical	52	N,NU,NJ424	Cylindrical	56
	HR33210J	Tapered	122	LAH45GM/GMZ	Linear	240	N,NU,NJ2205	Cylindrical	60	N,NU,NJ426	Cylindrical	56
	HR33211J	Tapered	122	LAH55	Linear	263	N,NU,NJ2206	Cylindrical	60	N,NU,NJ428	Cylindrical	56
HR33212J	Tapered	122	LAH55AN/ANZ	Linear	236	N,NU,NJ2207	Cylindrical	60	N,NU,NJ430	Cylindrical	56	
HR33213J	Tapered	122	LAH55BN/BNZ	Linear	236	N,NU,NJ2208	Cylindrical	60	N,NU,NJ005	Cylindrical	58	
HR33214J	Tapered	122	LAH55EL/FLZ	Linear	238	N,NU,NJ2209	Cylindrical	60	N,NU,NJ006	Cylindrical	58	
HR33215J	Tapered	122	LAH55EM/EMZ	Linear	240	N,NU,NJ221	Cylindrical	52	N,NU,NJ007	Cylindrical	58	
HR33216J	Tapered	122	LAH55GL/HLZ	Linear	238	N,NU,NJ2210	Cylindrical	60	N,NU,NJ008	Cylindrical	58	
HR33217J	Tapered	122	LAH55GM/GMZ	Linear	240	N,NU,NJ2211	Cylindrical	60	N,NU,NJ009	Cylindrical	58	
HR33220J	Tapered	122	LAH65	Linear	266	N,NU,NJ2212	Cylindrical	60	N,NU,NJ010	Cylindrical	58	
JL69310	Tapered	134	LAH65AN/ANZ	Linear	236	N,NU,NJ2213	Cylindrical	60	N,NU,NJ011	Cylindrical	58	
JL69349	Tapered	134	LAH65BN/BNZ	Linear	236	N,NU,NJ2214	Cylindrical	60	N,NU,NJ012	Cylindrical	58	
LE09'S	Linear	253	LAH65EL/FLZ	Linear	238	N,NU,NJ2215	Cylindrical	60	N,NU,NJ013	Cylindrical	58	
LE12'S	Linear	253	LAH65EM/EMZ	Linear	240	N,NU,NJ2216	Cylindrical	60	N,NU,NJ014	Cylindrical	58	
LE15'S	Linear	253	LAH65GL/HLZ	Linear	238	N,NU,NJ2217	Cylindrical	60	N,NU,NJ015	Cylindrical	58	
LIH15	Linear	242	LAH65GM/GMZ	Linear	240	N,NU,NJ2218	Cylindrical	60	N,NU,NJ016	Cylindrical	58	
LIH15-01	Linear	242	LA515	Linear	263	N,NU,NJ2219	Cylindrical	60	N,NU,NJ017	Cylindrical	58	
LIH15-01Z	Linear	242	LA515AL/ALZ	Linear	246	N,NU,NJ222	Cylindrical	52	N,NU,NJ018	Cylindrical	58	
LIH15-Z	Linear	242	LA515CL/CLZ	Linear	246	N,NU,NJ2220	Cylindrical	60	N,NU,NJ019	Cylindrical	58	
LIH20	Linear	242	LA515EL/ELZ	Linear	248	N,NU,NJ2222	Cylindrical	60	N,NU,NJ020	Cylindrical	58	
LIH20-01	Linear	242	LA515FL/FLZ	Linear	248	N,NU,NJ2224	Cylindrical	60	N,NU,NJ021	Cylindrical	58	
LIH20-01Z	Linear	242	LA515KL/KLZ	Linear	248	N,NU,NJ2226	Cylindrical	60	N,NU,NJ022	Cylindrical	58	
LIH20-Z	Linear	242	LA520	Linear	263	N,NU,NJ2228	Cylindrical	60	N,NU,NJ024	Cylindrical	58	
LIH25	Linear	242	LA520AL/ALZ	Linear	246	N,NU,NJ2230	Cylindrical	60	N,NU,NJ026	Cylindrical	58	
LIH25-01	Linear	242	LA520CL/CLZ	Linear	246	N,NU,NJ2232	Cylindrical	60	N,NU,NJ028	Cylindrical	58	
LIH25-01Z	Linear	242	LA520EL/ELZ	Linear	248	N,NU,NJ2234	Cylindrical	60	N,NU,NJ030	Cylindrical	58	
LIH25-Z	Linear	242	LA520FL/FLZ	Linear	248	N,NU,NJ2236	Cylindrical	60	N,NU,NJ032	Cylindrical	58	
LIH30	Linear	242	LA520KL/KLZ	Linear	248	N,NU,NJ2238	Cylindrical	60	N,NU,NJ034	Cylindrical	58	
LIH30-01	Linear	242	LA525	Linear	263	N,NU,NJ224	Cylindrical	52	N,NU,NJ036	Cylindrical	58	
LIH30-01Z	Linear	242	LA525AL/ALZ	Linear	246	N,NU,NJ2240	Cylindrical	60	N,NU,NJ038	Cylindrical	58	
LIH30-Z	Linear	242	LA525CL/CLZ	Linear	246	N,NU,NJ2244	Cylindrical	60	N,NU,NJ040	Cylindrical	58	
LIH35	Linear	242	LA525EL/ELZ	Linear	248	N,NU,NJ2248	Cylindrical	60	N,NU,NJ044	Cylindrical	58	
LIH35-01	Linear	242	LA525FL/FLZ	Linear	248	N,NU,NJ2252	Cylindrical	60	N,NU,NJ048	Cylindrical	58	
LIH35-01Z	Linear	242	LA525KL/KLZ	Linear	248	N,NU,NJ226	Cylindrical	52	N,NU,NJ052	Cylindrical	58	
LIH35-Z	Linear	242	LA530	Linear	263	N,NU,NJ228	Cylindrical	52	N,NU,NJ056	Cylindrical	58	
LIH45	Linear	242	LA530AL/ALZ	Linear	246	N,NU,NJ230	Cylindrical	52	N,NU,NJ060	Cylindrical	58	
LIH45-01	Linear	242	LA530CL/CLZ	Linear	246	N,NU,NJ2305	Cylindrical	62	N00	Split Block	181	
LIH45-01Z	Linear	242	LA530EL/ELZ	Linear	248	N,NU,NJ2306	Cylindrical	62	N01	Split Block	181	
LIH45-Z	Linear	242	LA530FL/FLZ	Linear	248	N,NU,NJ2307	Cylindrical	62	N02	Split Block	181	
LIH55	Linear	242	LA530KL/KLZ	Linear	248	N,NU,NJ2308	Cylindrical	62	N03	Split Block	181	
LIH55-01	Linear	242	LA535	Linear	263	N,NU,NJ2309	Cylindrical	62	N04	Split Block	181	
LIH55-01Z	Linear	242	LA535AL/ALZ	Linear	246	N,NU,NJ2310	Cylindrical	62	N05	Split Block	181	
LIH55-Z	Linear	242	LA535CL/CLZ	Linear	246	N,NU,NJ2311	Cylindrical	62	N06	Split Block	181	
LIH65	Linear	242	LA535EL/ELZ	Linear	248	N,NU,NJ2312	Cylindrical	62	N07	Split Block	181	
LIH65-01	Linear	242	LA535FL/FLZ	Linear	248	N,NU,NJ2313	Cylindrical	62	N08	Split Block	181	
LIH65-01Z	Linear	242	LA535KL/KLZ	Linear	248	N,NU,NJ2314	Cylindrical	62	N09	Split Block	181	
LIH65-Z	Linear	242	LAU09	Linear	263	N,NU,NJ2315	Cylindrical	62	N10	Split Block	181	
LI515	Linear	250	LAU09ARS	Linear	252	N,NU,NJ2316	Cylindrical	62	N1006	Precision	218	
LI515T	Linear	250	LAU09TRS	Linear	252	N,NU,NJ2317	Cylindrical	62	N1007	Precision	218	
LI520	Linear	250	LAU12	Linear	263	N,NU,NJ2318	Cylindrical	62	N1008	Precision	218	
LI525	Linear	250	LAU12ARS	Linear	252	N,NU,NJ2319	Cylindrical	52	N1009	Precision	218	
LI530	Linear	250	LAU12TRS	Linear	252	N,NU,NJ2320	Cylindrical	62	N1010	Precision	218	
LI535	Linear	250	LAU15	Linear	263	N,NU,NJ2322	Cylindrical	62	N1011	Precision	218	
LIU09'S	Linear	252	LAU15ALS	Linear	252	N,NU,NJ2324	Cylindrical	62	N1012	Precision	218	
LIU09'TS	Linear	252	LAW17	Linear	263	N,NU,NJ2326	Cylindrical	62	N1013	Precision	218	
LIU12'S	Linear	252	LAW17EL/ELZ	Linear	254	N,NU,NJ2328	Cylindrical	62	N1014	Precision	218	
LIU12'TS	Linear	252	LAW21	Linear	263	N,NU,NJ2330	Cylindrical	62	N1015	Precision	218	
LIU15'S	Linear	252	LAW21EL/ELZ	Linear	254	N,NU,NJ2332	Cylindrical	62	N1016	Precision	218	
LIW17	Linear	254	LAW27	Linear	263	N,NU,NJ2334	Cylindrical	62	N1017	Precision	218	
LIW21	Linear	254	LAW27EL/ELZ	Linear	254	N,NU,NJ2336	Cylindrical	62	N1018	Precision	218	
LIW27	Linear	254	LAW35	Linear	263	N,NU,NJ2338	Cylindrical	62	N1019	Precision	218	
LIW35	Linear	254	LAW35EL/ELZ	Linear	254	N,NU,NJ234	Cylindrical	52	N1020	Precision	218	
LIW50	Linear	254	LAW50	Linear	263	N,NU,NJ2340	Cylindrical	62	N1021	Precision	218	
L44610	Tapered	132	LAW50EL/ELZ	Linear	254	N,NU,NJ236	Cylindrical	52	N1022	Precision	218	
L44610	Tapered	132	LM102910	Tapered	134	N,NU,NJ238	Cylindrical	52	N1024	Precision	218	
L44643	Tapered	132	LM102949	Tapered	134	N,NU,NJ240	Cylindrical	52	N1026	Precision	218	
L44649	Tapered	132	LM11710	Tapered	132	N,NU,NJ244	Cylindrical	52	N1028	Precision	218	
L45410	Tapered	132	LM11749	Tapered	132	N,NU,NJ248	Cylindrical	52	N11	Split Block	181	
L45449	Tapered	132	LM11910	Tapered	132	N,NU,NJ252	Cylindrical	52	N12	Split Block	181	
L68110	Tapered	134	LM11949	Tapered	132	N,NU,NJ256	Cylindrical	52	N13	Split Block	181	
L68111	Tapered	134	LM12710	Tapered	132	N,NU,NJ260	Cylindrical	52	N14	Split Block	181	
L68149	Tapered	134	LM12711	Tapered	132	N,NU,NJ305	Cylindrical	54	N44	Split Block	181	
L68149	Tapered	134	LM12749	Tapered	132	N,NU,NJ306	Cylindrical	54	NK3005	Precision	220	
LAE09	Linear	263	LM12749	Tapered	132	N,NU,NJ307	Cylindrical	54	NK3006	Precision	220	
LAE09ARS	Linear	253	LM29710	Tapered	134	N,NU,NJ308	Cylindrical	54	NK3007	Precision	220	
LAE09TRS	Linear	253	LM29749	Tapered	134	N,NU,NJ309	Cylindrical	54	NK3008	Precision	220	
LAE12	Linear	263	LM48510	Tapered	134	N,NU,NJ310	Cylindrical	54	NK3009	Precision	220	
LAE12ARS	Linear	253	LM48548	Tapered	134	N,NU,NJ311	Cylindrical	54	NK3010	Precision	220	
LAE15	Linear	263	LM501310	Tapered	134	N,NU,NJ312	Cylindrical	54	NK3011	Precision	220	
LAE15ARS	Linear	253	LM501314	Tapered	134	N,NU,NJ313	Cylindrical	54	NK3012	Precision	220	
LAH15	Linear	263	LM501349	Tapered	134	N,NU,NJ314	Cylindrical	54	NK3013	Precision	220	
LAH15AN/ANZ	Linear	236	LM501349	Tapered	134	N,NU,NJ315	Cylindrical	54	NK3014	Precision	220	
LAH15EL/FLZ	Linear	238	LM603011	Tapered	134	N,NU,NJ316	Cylindrical	54	NK3015	Precision	220	
LAH15EM/EMZ	Linear	240	LM603012	Tapered	136	N,NU,NJ317	Cylindrical	54	NK3016	Precision	220	
LAH15GL/HLZ	Linear	238	LM603049	Tapered	134	N,NU,NJ318	Cylindrical	54	NK3017	Precision	220	
LAH15GM/GMZ	Linear	240	LM603049	Tapered	136	N,NU,NJ319	Cylindrical	54	NK3018	Precision	220	
LAH20	Linear	263	LM67010	Tapered	134	N,NU,NJ320	Cylindrical	54	NK3019	Precision	220	
LAH20AN/ANZ	Linear	236	LM67048	Tapered	134	N,NU,NJ321	Cylindrical	54	NK3020	Precision	220	
LAH20BN/BNZ	Linear	236	LS15	Linear	244	N,NU,NJ322	Cylindrical	54	NK3021	Precision	220	
LAH20EL/FLZ	Linear	238	LS20	Linear	244	N,NU,NJ324	Cylindrical	54	NK3022	Precision	220	
LAH20EM/EMZ	Linear	240	LS25	Linear	244	N,NU,NJ326	Cylindrical	54	NK3023	Precision	220	
LAH20GL/HLZ	Linear	238	LS30	Linear	244	N,NU,NJ328	Cylindrical	54	NK3024	Precision	220	
LAH20GM/GMZ	Linear	24										

Bearing No.			Bearing No.			Bearing No.			Bearing No.		
(prefix, no., Suffix)	Section	Page	(prefix, no., Suffix)	Section	Page	(prefix, no., Suffix)	Section	Page	(prefix, no., Suffix)	Section	Page
NN3932	Precision	222	SAF610	Split Block	166	SNW08X1-3/8	Split Block	178	W06	Split Block	181
NN3934	Precision	222	SAF611	Split Block	166	SNW08X1-5/16	Split Block	178	W07	Split Block	181
NN3936	Precision	222	SAF613	Split Block	166	SNW09X1-1/2	Split Block	178	W08	Split Block	181
NN3938	Precision	222	SAF615	Split Block	166	SNW09X1-3/8	Split Block	178	W09	Split Block	181
NN3940	Precision	222	SAF616	Split Block	166	SNW09X1-7/16	Split Block	178	W10	Split Block	181
NN3944	Precision	222	SAF617	Split Block	166	SNW109X1-1/2	Split Block	179	W11	Split Block	181
NN3948	Precision	222	SAF618	Split Block	166	SNW109X1-7/16	Split Block	179	W12	Split Block	181
NN3952	Precision	222	SAF620	Split Block	166	SNW10X1-11/16	Split Block	178	W13	Split Block	181
NN3956	Precision	222	SAF622	Split Block	166	SNW10X1-3/4	Split Block	178	W14	Split Block	181
NW32X5-7/16	Split Block	178	SAF624	Split Block	166	SNW10X1-5/8	Split Block	178	W15	Split Block	181
R10	Ball Bearings	12	SAF626	Split Block	166	SNW110X1-11/16	Split Block	179	W16	Split Block	181
R10ZZ/W	Ball Bearings	12	SAF628	Split Block	166	SNW110X1-3/4	Split Block	179	W17	Split Block	181
R12	Ball Bearings	12	SAF630	Split Block	166	SNW111X1-15/16	Split Block	179	W18	Split Block	181
R12ZZ/W	Ball Bearings	12	SAF632	Split Block	166	SNW111X1-7/8	Split Block	179	W19	Split Block	181
R14	Ball Bearings	12	SAF634	Split Block	166	SNW111X2	Split Block	179	W20	Split Block	181
R14ZZ	Ball Bearings	12	SAF636	Split Block	166	SNW113X2-1/4	Split Block	179	W21	Split Block	181
R16	Ball Bearings	12	SAF638	Split Block	166	SNW113X2-3/16	Split Block	179	W22	Split Block	181
R16ZZ	Ball Bearings	12	SAF640	Split Block	166	SNW115X2-1/2	Split Block	179	W24	Split Block	181
R18	Ball Bearings	12	SDAF060K/10-15/16	Split Block	168	SNW115X2-3/8	Split Block	179	W26	Split Block	181
R18ZZ	Ball Bearings	12	SDAF060K/11	Split Block	168	SNW115X2-7/16	Split Block	179	W28	Split Block	181
R20	Ball Bearings	12	SDAF064K/11-1/2	Split Block	168	SNW116X2-11/16	Split Block	179	W30	Split Block	181
R20ZZ	Ball Bearings	12	SDAF064K/11-15/16	Split Block	168	SNW116X2-3/4	Split Block	179	W32	Split Block	181
R22	Ball Bearings	12	SDAF064K/11-7/16	Split Block	168	SNW117X2-15/16	Split Block	179	W34	Split Block	181
R22ZZ	Ball Bearings	12	SDAF064K/12	Split Block	168	SNW117X3	Split Block	179	W36	Split Block	181
R24	Ball Bearings	12	SDAF068K/12-1/2	Split Block	168	SNW118X3/16	Split Block	179	W38	Split Block	181
R24A	Ball Bearings	12	SDAF068K/12-7/16	Split Block	168	SNW118X3-1/4	Split Block	179	W40	Split Block	181
R2A	Ball Bearings	12	SDAF072K/12-15/16	Split Block	168	SNW11X1-13/16	Split Block	178	W44	Split Block	181
R3	Ball Bearings	12	SDAF072K/13	Split Block	168	SNW11X1-15/16	Split Block	178	WBK04R-11(Round)	Linear	273
R3ZZ	Ball Bearings	12	SDAF072K/13-1/2	Split Block	168	SNW11X1-3/4	Split Block	178	WBK06-01A(Square)	Linear	273
R4AA	Ball Bearings	12	SDAF072K/13-7/16	Split Block	168	SNW11X1-7/8	Split Block	178	WBK06-11(Round)	Linear	273
R4AAZZ	Ball Bearings	12	SDAF076K/13-15/16	Split Block	168	SNW11X2	Split Block	178	WBK06R-11(Round)	Linear	273
R4B	Ball Bearings	12	SDAF076K/14	Split Block	168	SNW120X3-1/2	Split Block	179	WBK08-01A(Square)	Linear	273
R6	Ball Bearings	12	SDAF220	Split Block	170	SNW120X3-7/16	Split Block	179	WBK08-11(Round)	Linear	273
R6ZZ/W	Ball Bearings	12	SDAF222	Split Block	170	SNW122X3-11/16	Split Block	179	WBK10-01A(Square)	Linear	273
R8	Ball Bearings	12	SDAF224	Split Block	170	SNW122X3-15/16	Split Block	179	WBK10-11(Round)	Linear	273
R8ZZ/W	Ball Bearings	12	SDAF226	Split Block	170	SNW122X4	Split Block	179	WBK12-01A(Square)	Linear	273
RNCT	Linear	268	SDAF228	Split Block	170	SNW124X4-1/4	Split Block	179	WBK12-11(Round)	Linear	273
RNFL	Linear	268	SDAF230	Split Block	170	SNW124X4-3/16	Split Block	179	WBK15-01A(Square)	Linear	273
RNFL	Linear	268	SDAF232	Split Block	170	SNW126X4-1/2	Split Block	179	WBK15-11(Round)	Linear	273
RNFL	Linear	268	SDAF234	Split Block	170	SNW126X4-7/16	Split Block	179	WBK20-01(Square)	Linear	273
RNSTL	Linear	268	SDAF236	Split Block	170	SNW128X4-15/16	Split Block	179	WBK20-11(Round)	Linear	273
SAF024K/4-3/16	Split Block	158	SDAF238	Split Block	170	SNW128X5	Split Block	179	WBK25-01(Square)	Linear	273
SAF026K/4-7/16	Split Block	158	SDAF240	Split Block	170	SNW130X5-1/4	Split Block	179	WBK25-11(Round)	Linear	273
SAF028K/4-15/16	Split Block	158	SDAF244	Split Block	170	SNW130X5-3/16	Split Block	179	X376RS	Ball Bearings	47
SAF030K/5-3/16	Split Block	158	SDAF316	Split Block	172	SNW132X5-7/16	Split Block	179	X421RS	Ball Bearings	47
SAF032K/5-7/16	Split Block	158	SDAF317	Split Block	172	SNW134X5-15/16	Split Block	179	X428	Ball Bearings	44
SAF034K/5-15/16	Split Block	158	SDAF318	Split Block	172	SNW134X6	Split Block	179	X501	Ball Bearings	47
SAF036K/6-7/16	Split Block	158	SDAF320	Split Block	172	SNW136X6-1/2	Split Block	179	X540XL	Ball Bearings	44
SAF038K/6-15/16	Split Block	158	SDAF322	Split Block	172	SNW136X6-7/16	Split Block	179	X549RS	Ball Bearings	47
SAF040K/7-3/16	Split Block	158	SDAF324	Split Block	172	SNW138X6-15/16	Split Block	179	X555	Ball Bearings	47
SAF044K/7-15/16	Split Block	158	SDAF326	Split Block	172	SNW138X7	Split Block	179	Z9504B	Ball Bearings	44
SAF048K/8-1/2	Split Block	158	SDAF328	Split Block	172	SNW13X2	Split Block	178			
SAF048K/8-15/16	Split Block	158	SDAF330	Split Block	172	SNW13X2-1/4	Split Block	178			
SAF048K/8-7/16	Split Block	158	SDAF332	Split Block	172	SNW13X2-3/16	Split Block	178			
SAF048K/9	Split Block	158	SDAF334	Split Block	172	SNW13X2-5/16	Split Block	178			
SAF052K/9-1/2	Split Block	158	SDAF336	Split Block	172	SNW140X7-3/16	Split Block	179			
SAF052K/9-7/16	Split Block	158	SDAF338	Split Block	172	SNW144X7-15/16	Split Block	179			
SAF056K/10	Split Block	158	SDAF340	Split Block	172	SNW144X8	Split Block	179			
SAF056K/10-1/2	Split Block	158	SDAF522	Split Block	174	SNW15X2-1/2	Split Block	178			
SAF056K/10-7/16	Split Block	158	SDAF524	Split Block	174	SNW15X2-3/8	Split Block	178			
SAF056K/9-15/16	Split Block	160	SDAF526	Split Block	174	SNW15X2-5/8	Split Block	178			
SAF216	Split Block	160	SDAF528	Split Block	174	SNW15X2-7/16	Split Block	178			
SAF217	Split Block	160	SDAF530	Split Block	174	SNW16X2-11/16	Split Block	178			
SAF218	Split Block	160	SDAF532	Split Block	174	SNW16X2-3/4	Split Block	178			
SAF220	Split Block	160	SDAF534	Split Block	174	SNW17X2-15/16	Split Block	178			
SAF222	Split Block	160	SDAF536	Split Block	174	SNW17X3	Split Block	178			
SAF224	Split Block	160	SDAF538	Split Block	174	SNW18X3	Split Block	178			
SAF226	Split Block	160	SDAF540	Split Block	174	SNW18X3-1/4	Split Block	178			
SAF228	Split Block	160	SDAF544	Split Block	174	SNW20X3-1/2	Split Block	178			
SAF230	Split Block	160	SDAF540	Split Block	174	SNW20X3-7/16	Split Block	178			
SAF232	Split Block	160	SDAF616	Split Block	176	SNW22X3-11/16	Split Block	178			
SAF234	Split Block	160	SDAF617	Split Block	176	SNW22X3-15/16	Split Block	178			
SAF236	Split Block	160	SDAF618	Split Block	176	SNW22X4	Split Block	178			
SAF238	Split Block	160	SDAF620	Split Block	176	SNW24X4-1/4	Split Block	178			
SAF240	Split Block	160	SDAF622	Split Block	176	SNW24X4-3/16	Split Block	178			
SAF244	Split Block	160	SDAF624	Split Block	176	SNW26X4-1/2	Split Block	178			
SAF308	Split Block	162	SDAF626	Split Block	176	SNW26X4-7/16	Split Block	178			
SAF309	Split Block	162	SDAF628	Split Block	176	SNW28X4-15/16	Split Block	178			
SAF310	Split Block	162	SDAF630	Split Block	176	SNW28X4-7/8	Split Block	178			
SAF311	Split Block	162	SDAF632	Split Block	176	SNW28X5	Split Block	178			
SAF313	Split Block	162	SDAF634	Split Block	176	SNW3024X4-3/16	Split Block	180			
SAF314	Split Block	162	SDAF636	Split Block	176	SNW3026X4-1/2	Split Block	180			
SAF315	Split Block	162	SDAF638	Split Block	176	SNW3026X4-7/16	Split Block	180			
SAF316	Split Block	162	SDAF640	Split Block	176	SNW3028X4-15/16	Split Block	180			
SAF317	Split Block	162	SNP3048X8-1/2	Split Block	180	SNW3028X5	Split Block	180			
SAF318	Split Block	162	SNP3048X8-15/16	Split Block	180	SNW3030X5-1/4	Split Block	180			
SAF320	Split Block	162	SNP3048X8-7/16	Split Block	180	SNW3030X5-3/16	Split Block	180			
SAF322	Split Block	162	SNP3048X9	Split Block	180	SNW3032X5-7/16	Split Block	180			
SAF324	Split Block	162	SNP3052X9-1/2	Split Block	180	SNW3034X5-15/16	Split Block	180			
SAF326	Split Block	162	SNP3052X9-7/16	Split Block	180	SNW3034X6	Split Block	180			
SAF328	Split Block	162	SNP3056X10	Split Block	180	SNW3036X6-1/2	Split Block	180			
SAF330	Split Block	162	SNP3056X10-1/2	Split Block	180	SNW3036X6-7/16	Split Block	180			
SAF332	Split Block	162	SNP3056X10-7/16	Split Block	180	SNW3038X6-15/16	Split Block	180			
SAF334	Split Block	162	SNP3056X9-15/16	Split Block	180	SNW3038X7	Split Block	180			
SAF336	Split Block	162	SNP3060X10-15/16	Split Block	180	SNW3040X7-3/16	Split Block	180			
SAF338	Split Block	162	SNP3060X11	Split Block	180	SNW3044X7-15/16	Split Block	180			
SAF340	Split Block	162	SNP3064X11-1/2	Split Block	180	SNW3044X8	Split Block	180			
SAF507	Split Block	164	SNP3064X12	Split Block	180	SNW30X5-1/4	Split Block	178			
SAF509	Split Block	164	SNP3068X12-1/2	Split Block	180	SNW30X5-3/16	Split Block	178			
SAF510	Split Block	164	SNP3068X12-7/16	Split Block	180	SNW32X5-1/2	Split Block	178			
SAF511	Split Block	164	SNP3072X13-7/16	Split Block	180	SNW32X5-3/4	Split Block	178			
SAF513	Split Block	164	SNP3076X13-15/16	Split Block	180	SNW34X5-15/16	Split Block	178			
SAF515	Split Block	164	SNP3076X14	Split Block	180	SNW34X6	Split Block	178			
SAF516	Split Block	164	SNP3080X15	Split Block	180	SNW36X6-1/2	Split Block	178			
SAF517	Split Block	164	SNP3084X15-3/4	Split Block	180	SNW36X6-7/16	Split Block	178			
SAF518	Split Block	164	SNP3088X16	Split Block	180	SNW38X6-15/16	Split Block	178			
SAF520	Split Block	164	SNP3088X16-1/2	Split Block	180	SNW38X7	Split Block	178			
SAF522	Split Block	164	SNP3092X17	Split Block	180	SNW40X7-3/16	Split Block	178			
SAF524	Split Block	164	SNP3096X18	Split Block	180	SNW40X7-3/8	Split Block	178			
SAF526	Split Block	164	SNP3500X18-1/2	Split Block	180	SNW44X7-1/2	Split Block	178			
SAF528	Split Block	164	SNW05X11/16	Split Block	178	SNW44X7-15/16	Split Block	178			
SAF530	Split Block	164	SNW05X3/4	Split Block	178	SNW44X7-7/8	Split Block	178			
SAF532	Split Block	164	SNW06X1	Split Block	178	SNW44X8	Split Block	178			
SAF534	Split Block	164	SNW06X15/16	Split Block	178	W00	Split Block	181			
SAF536	Split Block	164	SNW0								

Conversion Factors

	To Convert From	To	Multiply By	To Convert From	To	Multiply By
Length						
	Inch [in]	Millimeter [mm]	25.400 000	Millimeter [mm]	Inch [in]	0.039 370
	Foot [ft]	Meter [m]	0.304 800	Meter [m]	Foot [ft]	3.280 840
	Yard [yd]	Meter [m]	0.914 400	Meter [m]	Yard [yd]	1.093 613
	Mile (U.S. Statute) [mi]	Kilometer [km]	1.609 347	Kilometer [km]	Mile (U.S. Statute) [mi]	0.621 370
Area						
	Square Inch [in ²]	Square Millimeter [mm ²]	645.16	Square Millimeter [mm ²]	Square Inch [in ²]	0.001550
	Square Foot [ft ²]	Square Meter [m ²]	0.092 903	Square Meter [m ²]	Square Foot [ft ²]	10.763 915
	Square Yard [yd ²]	Square Meter [m ²]	0.836 127	Square Meter [m ²]	Square Yard [yd ²]	1.195 991
	Square Mile [mi ²] (U.S. Statute)	Square Kilometer [km ²]	2.589 998	Square Kilometer [km ²]	Square Mile [mi ²] (U.S. Statute)	0.386 101
	Acre	Square Meter [m ²]	4046.873	Square Meter [m ²]	Acre	0.000 247
	Acre	Hectare	0.404 687	Hectare	Acre	2.471 046
Volume						
	Cubic Inch [in ³]	Cubic Millimeter [mm ³]	16387.06	Cubic Millimeter [mm ³]	Cubic Inch [in ³]	0.000061
	Cubic Foot [ft ³]	Cubic Meter [m ³]	0.028 317	Cubic Meter [m ³]	Cubic Foot [ft ³]	35.314 662
	Cubic Yard [yd ³]	Cubic Meter [m ³]	0.764 555	Cubic Meter [m ³]	Cubic Yard [yd ³]	1.307 950
	Gallon (U.S. Liquid) [gal]	Litre [l]	3.785 412	Litre [l]	Gallon (U.S. Liquid) [gal]	0.264 172
	Quart (U.S. Liquid) [qt]	Litre [l]	0.946 353	Litre [l]	Quart (U.S. Liquid) [qt]	1.056 688
Mass						
	Ounce (Avoirdupois) [oz]	Gram [g]	28.349 520	Gram [g]	Ounce (Avoirdupois)	0.035 274 [oz]
	Pound (Avoirdupois) [lb]	Kilogram [kg]	0.453 592	Kilogram [kg]	Pound (Avoirdupois) [lb]	2.204 624
	Short Ton	Kilogram [kg]	907.185	Kilogram [kg]	Short Ton	0.00110
Force						
	Pound-Force [lbf]	Kilogram [kg]	0.453 592	Kilogram [kg]	Pound-Force [lbf]	2.204 624
	Pound-Force [lbf]	Newton [N]	4.448 222	Newton [N]	Pound-Force [lbf]	0.224 809
Bending Moment						
	Pound-Force-Inch [lbf-in]	Newton-Meter [N-m]	0.112 985	Newton-Meter [N-m]	Pound-Force-Inch [lbf-in]	8.850 732
	Pound-Force-Foot [lbf-ft]	Newton-Meter [N-m]	1.355 818	Newton-Meter [N-m]	Pound-Force-Foot [lbf-ft]	0.737 562
Pressure, Stress						
	Pound-Force per Square Inch [lbf/in ²]	Kilopascal [kPa]	6.894 757	Kilopascal [kPa]	Pound-Force per Square Inch [lbf/in ²]	0.145 038
	Foot of Water (39.2 F)	Kilopascal [kPa]	2.988 980	Kilopascal [kPa]	Foot of Water (39.2 F)	0.334 562
	Inch of Mercury (32 F)	Kilopascal [kPa]	3.386 380	Kilopascal [kPa]	Inch of Mercury (32 F)	0.295 301
Energy, Work, Heat						
	Foot-Pound-Force [ft-lbf]	Joule [J]	1.355 818	Joule [J]	Foot-Pound-Force [ft-lbf]	0.737 562
	British Thermal Unit [Btu]	Joule [J]	1055.056	Joule [J]	British Thermal Unit [Btu]	0.000948
	Calorie [cal]	Joule [J]	4.186 800	Joule [J]	Calorie [cal]	0.238 846
	Kilowatt Hour [kW-h]	Joule [J]	3600000	Joule [J]	Kilowatt Hour [kW-h]	2.78-7
Power						
	Foot-Pound-Force / Second [ft-lbs/s]	Watt [W]	1.355 818	Watt [W]	Foot-Pound-Force / Second [ft-lbs/s]	0.737 562
	British Thermal Unit / Hour [Btu/h]	Watt [W]	0.293 071	Watt [W]	British Thermal Unit / Hour [Btu/h]	3.412 142
	Horsepower (550 Ft. Lbf/s) [hp]	Kilowatt [kW]	0.745 700	Kilowatt [kW]	Horsepower (550 Ft. Lbf/s) [hp]	1.341 022
Angle						
	Degree	Radian [rad]	0.017 453	Radian [rad]	Degree	57.295 788
Temperature						
	Degree Fahrenheit [F]	Degree Celsius [C]	(F° -32)/1.8	Degree Celsius [C]	Degree Fahrenheit [F]	1.8xC°+32