

Four-row linear recirculating ball bearing and guideway assemblies

Full complement
With Quad-Spacers

Four-row linear recirculating ball bearing and guideway assemblies

Full complement
Standard, L, N and NL carriages

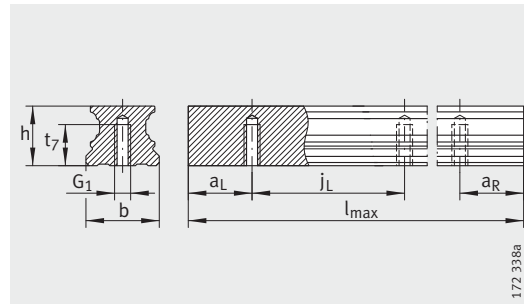

TKVD..-U

Dimension table · Dimensions in mm																
Designation	Dimensions				Mounting dimensions											
	l _{max} ¹⁾	H	B	L	A ₁	J _B	b <small>-0,005 -0,03</small>	A ₂	L ₁	J _L	J _{LZ}	j _L	a _L , a _R ²⁾		H ₁	H ₄
													min.	max.		
KUVE15-B	1 200	24	47	59,6	16	38	15	4,5	39,8	30	26	60	20	53	4,3	7,6
KUVE20-B	2 960	30	63	69,8	21,5	53	20	5	50,4	40	35	60	20	53	4,5	11
KUVE20-B-L		87,3		67,9												
KUVE20-B-N		69,8		50,4												
KUVE20-B-NL		87,3		67,9												
KUVE25-B	2 960	36	70	81,7	23,5	57	23	6,5	60,7	45	40	60	20	53	5,1	10,9
KUVE25-B-L		107,5		86,5												
KUVE25-B-N		81,7		60,7												
KUVE25-B-NL		107,5		86,5												
KUVE30-B	2 960	42	90	97,4	31	72	28	9	72	52	44	80	20	71	5,9	13,8
KUVE30-B-L		125,4		100												
KUVE30-B-N		97,4		72												
KUVE30-B-NL		125,4		100												
KUVE35-B	2 960	48	100	110,4	33	82	34	9	80	62	52	80	20	71	6,7	14,3
KUVE35-B-L		143,4		113												
KUVE35-B-N		110,4		80												
KUVE35-B-NL		143,4		113												
KUVE45-B	2 940	60	120	139	37,5	100	45	10	102,5	80	60	105	20	94	9,7	19,9
KUVE45-B-L		171,1		134,6												
KUVE45-B-N		139		102,5												
KUVE45-B-NL		171,1		134,6												
KUVE55-B	2 520	70	140	172	43,5	116	53	12	132	95	70	120	20	107	13,5	22,7
KUVE55-B-L				210					170							

For further table values, see page 266 and page 267.

- 1) Maximum length of single-piece guideways. For permissible number of guideway pieces, see page 259. Maximum single-piece guideway length of 6 m available by agreement.
- 2) a_L and a_R are dependent on the guideway length.
- 3) If there is a possibility of preload loss due to settling, the fixing screws should be secured against rotation.
- 4) ① Locating face
② Marking

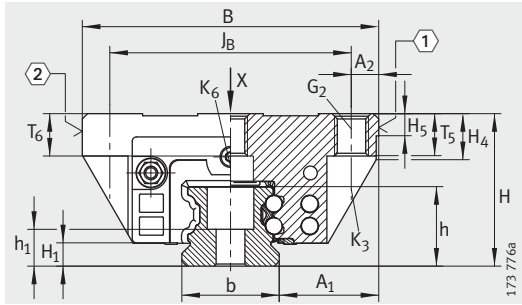

KUVE...-B (-L, -N, -NL)
①, ②⁴⁾

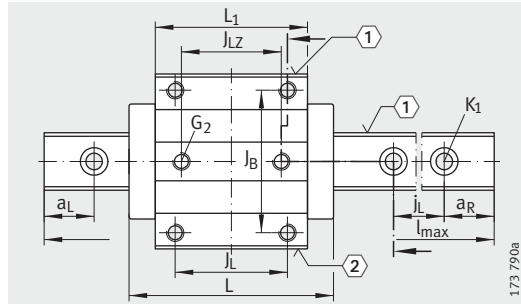

KUVE...-B (-L, -N, -NL) · View rotated 90°
①, ②⁴⁾

						Fixing screws ³⁾											
H ₅	T ₅	T ₆	t ₇	h	h ₁	DIN ISO 4 762-12.9				DIN 7984-8.8							
						G ₁	M _A Nm	G ₂	M _A Nm	K ₁	M _A Nm	K ₃	M _A Nm	K ₆	M _A Nm	K ₆	M _A Nm
4,75	7	5,8	8	15	8,15	M5	10	M5	5,8	M4	5	M4	5	-	-	M4	2
5,25	10	7,5	10	17	9,1	M6	17	M6	10	M5	10	M5	10	M5	10	-	-
	8	6										M5	10	-	-	M5	4
5,25	10	10	12	18,7	8,7	M6	17	M8	24	M6	17	M6	17	M6	17	-	-
		8												-	-	M6	8
6,25	12	11,5	15	23,5	11,5	M8	41	M10	41	M8	41	M8	41	M8	41	-	-
		9												-	-	M8	12
6,75	13	12,3	15	27	15	M8	41	M10	41	M8	41	M8	41	M8	41	-	-
		8,3												-	-	M8	12
9,25	15	15	20	34,2	16,2	M12	140	M12	83	M12	140	M10	83	M10	83	-	-
		11												-	-	M10	35
11,25	21	18	22	41,5	19,5	M14	220	M14	140	M14	220	M12	140	M12	140	-	-

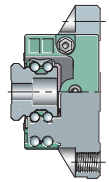

Four-row linear recirculating ball bearing and guideway assemblies

Full complement
Standard, L, N and NL carriages

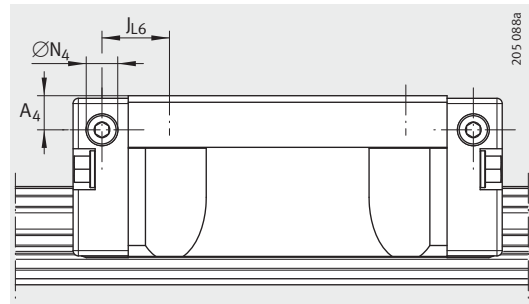

Lubrication connector on lateral face

Dimension table (continued) · Dimensions in mm

Designation	Carriage		Guideway		
	Designation	Mass m ≈kg	Designation	Mass m ≈kg/m	Closing plug K ₂
KUVE15-B	KWVE15-B	0,2	TKVD15-B (-U) ²⁾	1,44	KA07-TN/A
KUVE20-B	KWVE20-B	0,44	TKVD20 (-U)	2,2	KA10-TN/A
KUVE20-B-L	KWVE20-B-L	0,59			
KUVE20-B-N	KWVE20-B-N	0,37			
KUVE20-B-NL	KWVE20-B-NL	0,51			
KUVE25-B	KWVE25-B	0,68	TKVD25(-U)	2,7	KA11-TN/A
KUVE25-B-L	KWVE25-B-L	1			
KUVE25-B-N	KWVE25-B-N	0,56			
KUVE25-B-NL	KWVE25-B-NL	0,82			
KUVE30-B	KWVE30-B	1,2	TKVD30(-U)	4,3	KA15-TN/A
KUVE30-B-L	KWVE30-B-L	1,7			
KUVE30-B-N	KWVE30-B-N	1			
KUVE30-B-NL	KWVE30-B-NL	1,5			
KUVE35-B	KWVE35-B	1,75	TKVD35(-U)	5,7	KA15-TN/A
KUVE35-B-L	KWVE35-B-L	2,52			
KUVE35-B-N	KWVE35-B-N	1,56			
KUVE35-B-NL	KWVE35-B-NL	2,23			
KUVE45-B	KWVE45-B	3,3	TKVD45(-U)	9,2	KA20-TN/A
KUVE45-B-L	KWVE45-B-L	4,3			
KUVE45-B-N	KWVE45-B-N	2,72			
KUVE45-B-NL	KWVE45-B-NL	3,38			
KUVE55-B	KWVE55-B	5,5	TKVD55-B(-U)	14	KA24-TN/A
KUVE55-B-L	KWVE55-B-L	6,6			

- 1) Calculation of basic load ratings in accordance with DIN 636.
Based on practical experience, it may be possible to increase the basic dynamic load rating.
- 2) The new carriages cannot be used on the previous guideways TKVD15(-U).
- 3) Tapered head lubrication nipple to DIN 71 412-B M6,
KUVE20-B to DIN 71 412-B M5 and KUVE15-B to DIN 3 405-B M3, supplied loose with delivery.
- 4) Maximum permissible screw depth for lubrication connectors.

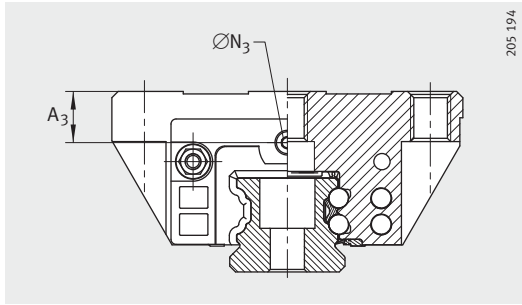

Lubrication connector on end face

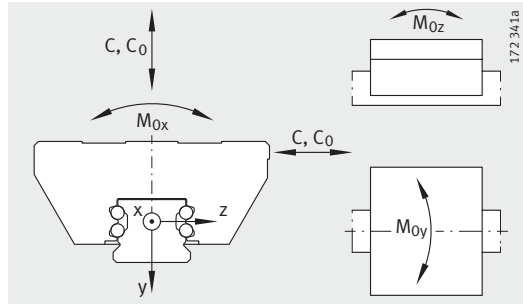

Load directions

Dimensioning of lubrication connectors						Load carrying capacity ¹⁾					
A ₃	ØN ₃		A ₄	ØN ₄		J _{L6}	Basic load ratings		Moment ratings		
		4)			4)		C N	C ₀ N	M _{0x} Nm	M _{0y} Nm	M _{0z} Nm
4,3	2,57	5,5	3,2	2,57	5,5	9,1	7 200	14 500	150	100	100
7,7	4,5	7	4,6	4,5	5,5	9,4	13 100	27 000	332	240	240
			18,9	16 200		36 500	452	430	430		
4,7	4,5	7	3,3	2,57	5,5	9,4	13 100	27 000	332	240	240
			18,9	16 200		36 500	452	430	430		
11	5,5	7	6,5	5,6	7	12,85	17 900	37 000	510	395	395
			25,75	23 400	54 000	745	825	825			
6	5,5	7	4	2,57	6	12,05	17 900	37 000	510	395	395
			24,95	23 400	54 000	745	825	825			
11,5	5,5	7	7	5,5	7	15,5	27 500	55 000	970	660	660
			29,5	34 500		74 000	1 320	1 180	1 180		
7,5	5,5	7	4,95	4,5	7	15,1	27 500	55 000	970	700	700
			29,1	34 500		74 000	1 310	1 240	1 240		
12,3	5,5	7	11	5,5	7	16	38 000	72 000	1 465	1 020	1 020
			32,5			47 500	100 000	2 625	1 890	1 890	
8,3	5,5	7	7	5,5	7	16	38 000	72 000	1 465	1 020	1 020
			32,5			47 500	100 000	2 025	1 890	1 890	
16,5	5,5	7	16,5	5,5	7	19,25	69 000	141 000	3 610	2 485	2 485
			35,3			82 000	181 000	4 635	4 000	4 000	
8,5	5,5	7	8,5	5,5	7	19,25	69 000	141 000	3 610	2 485	2 485
			35,5			82 000	181 000	5 635	4 000	4 000	
15	5,5	7	15	5,5	7	30,5	104 000	213 000	5 600	2 730	2 730
			49,5			127 000	285 000	7 500	4 725	4 800	

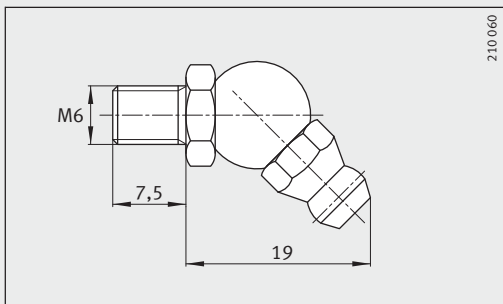
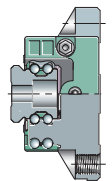

Lubrication nipple³⁾

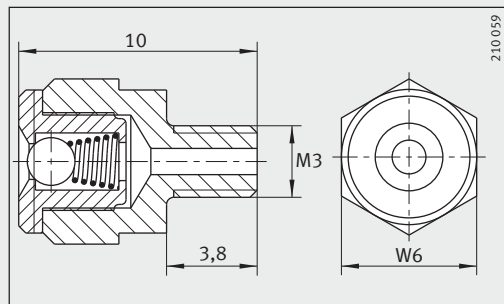

Lubrication nipple³⁾,
width across flats W = 6 mm

Four-row linear recirculating ball bearing and guideway assemblies

Full complement
H, S, SN carriages

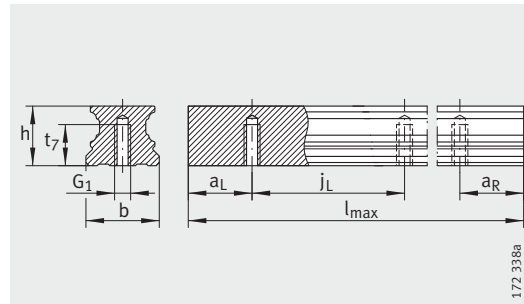

TKVD..-U

Dimension table · Dimensions in mm													
Designation	Dimensions				Mounting dimensions								
	$l_{max}^{1)}$	H	B	L	A_1	J_B	b -0,005 -0,03	A_2	L_1	J_L	j_L	$a_L, a_R^{2)}$	
												min.	max.
KUVE15-B-H	1 200	28	34	59,6	9,5	26	15	4	39,8	26	60	20	53
KUVE15-B-S		24											
KUVE20-B-H	2 960	30	44	69,8	12	32	20	6	50,4	36	60	20	53
KUVE20-B-S		27											
KUVE20-B-SN		27											
KUVE25-B-H	2 960	40	48	81,7	12,5	35	23	6,5	60,7	35	60	20	52
KUVE25-B-S		36											
KUVE25-B-SN		31											
KUVE30-B-H	2 960	45	60	97,4	16	40	28	10	72	40	80	20	71
KUVE30-B-S		42											
KUVE30-B-SN		38											
KUVE35-B-H	2 960	55	70	110,4	18	50	34	10	80	50	80	20	71
KUVE35-B-S		48											
KUVE35-B-SN		44											
KUVE45-B-H	2 940	70	86	139	20,5	60	45	13	102,5	60	105	20	94
KUVE45-B-S		60											
KUVE45-B-SN		52											
KUVE55-B-S	2 520	70	100	172	23,5	75	53	12,5	132	75	120	20	107

For further table values, see page 270 and page 271.

- 1) Maximum length of single-piece guideways. For permissible number of guideway pieces, see page 259.
Maximum single-piece guideway length of 6 m available by agreement.
- 2) a_L and a_R are dependent on the guideway length.
- 3) If there is a possibility of preload loss due to settling, the fixing screws should be secured against rotation.
- 4) ① Locating face
② Marking

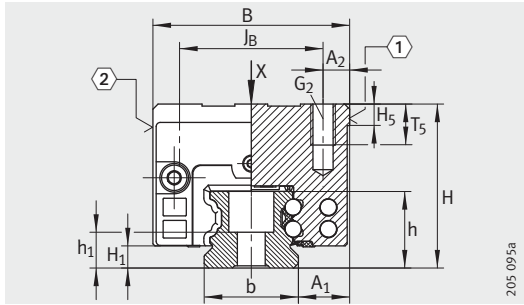

KUBE...-B (-H, -S, -SN)
 ①, ②⁴⁾

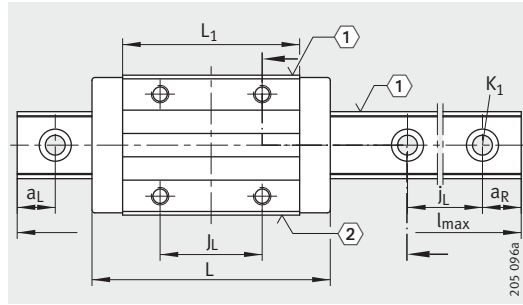

KUBE...-B (-H, -S, -SN) · View rotated 90°
 ①, ②⁴⁾

						Fixing screws ³⁾					
H ₁	H ₅	T ₅	t ₇	h	h ₁	G ₁		G ₂		K ₁	
						DIN ISO 4 762-12.9		M _A Nm	M _A Nm	M _A Nm	M _A Nm
4,3	4,75	6	8	15	8,15	M5	10	M4	5	M4	5
4,5	5,25	7,5	10	17	9,1	M6	17	M5	10	M5	10
5,1	5,25	10	12	18,7	8,7	M6	17	M6	17	M6	17
		7,5									
5,9	6,25	13,5	15	23,5	11,5	M8	41	M8	41	M8	41
		11									
6,7	6,75	13,5	15	27	15	M8	41	M8	41	M8	41
9,7	9,25	23,5	20	34,2	16,2	M12	140	M10	83	M12	140
		17									
		16,5									
13,5	11,25	15	22	41,5	19,6	M14	220	M12	140	M14	220

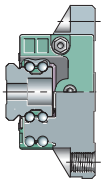

Four-row linear recirculating ball bearing and guideway assemblies

Full complement
H, S, SN carriages

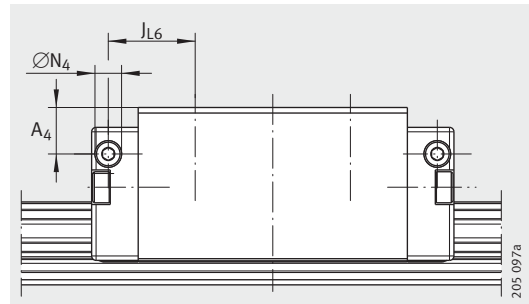

Lubrication connector on lateral face

Dimension table (continued) · Dimensions in mm

Designation	Carriage		Guideway		
	Designation	Mass m ≈kg	Designation	Mass m ≈kg/m	Closing plug K ₂
KUVE15-B-H	KWVE15-B-H	0,2	TKVD15-B (-U) ²⁾	1,44	KA07-TN/A
KUVE15-B-S	KWVE15-B-S	0,16			
KUVE20-B-H	KWVE20-B-H	0,34	TKVD20 (-U)	2,2	KA10-TN/A
KUVE20-B-S	KWVE20-B-S				
KUVE20-B-SN	KWVE20-B-SN				
KUVE25-B-H	KWVE25-B-H	0,65	TKVD25(-U)	2,7	KA11-TN/A
KUVE25-B-S	KWVE25-B-S	0,56			
KUVE25-B-SN	KWVE25-B-SN	0,45			
KUVE30-B-H	KWVE30-B-H	1,04	TKVD30(-U)	4,3	KA15-TN/A
KUVE30-B-S	KWVE30-B-S	0,94			
KUVE30-B-SN	KWVE30-B-SN	0,8			
KUVE35-B-H	KWVE35-B-H	1,71	TKVD35(-U)	5,7	KA15-TN/A
KUVE35-B-S	KWVE35-B-S	1,3			
KUVE35-B-SN	KWVE35-B-SN	1,24			
KUVE45-B-H	KWVE45-B-H	3,36	TKVD45(-U)	9,2	KA20-TN/A
KUVE45-B-S	KWVE45-B-S	2,67			
KUVE45-B-SN	KWVE45-B-SN	2,12			
KUVE55-B-S	KWVE55-B-S	4,35	TKVD55-B(-U)	14	KA24-TN/A

¹⁾ Calculation of basic load ratings in accordance with DIN 636.

Based on practical experience, it may be possible to increase the basic dynamic load rating.

²⁾ The new carriages cannot be used on the previous guideways TKVD15(-U).

³⁾ Tapered head lubrication nipple to DIN 71 412-B M6,
KUVE20-B to DIN 71 412-B M5 and KUVE15-B to DIN 3 405-B M3, supplied loose with delivery.

⁴⁾ Maximum permissible screw depth for lubrication connectors.

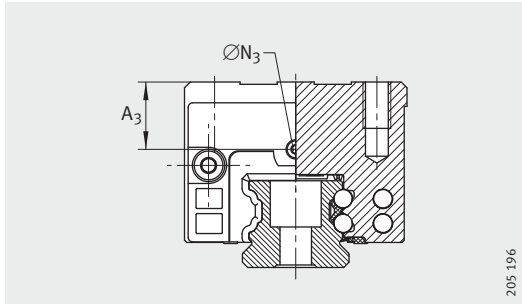

Lubrication connector on end face

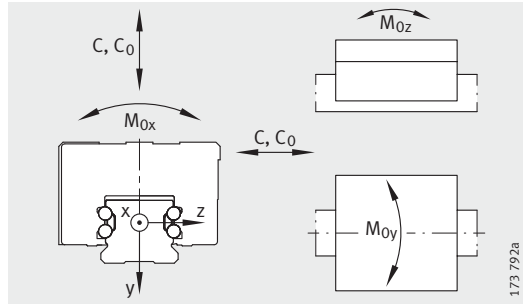

Load directions

Dimensioning of lubrication connectors							Load carrying capacity ¹⁾				
A_3	$\varnothing N_3$		A_4	$\varnothing N_4$		J_{L6}	Basic load ratings		Moment ratings		
		⁴⁾			⁴⁾		C N	C_0 N	M_{0x} Nm	M_{0y} Nm	M_{0z} Nm
8,3 4,3	2,57	5,5	7,2	2,57	5,5	11,1	7 200	14 500	150	100	100
			3,2								
8 4,7	4,5	7	4,6	4,5	5,5	11,4	13 100	27 000	332	240	240
			3,3								
15 11 6	5,5	7	10,5	5,6	7	17,9	17 900	37 000	510	395	395
			6,5								
			4								
14,5 11,5 7,5	5,5	7	10	5,5	7	21,5	27 500	55 000	970	700	700
			7								
			4,95								
19,3 12,3 8,3	5,5	7	18	5,5	7	22	38 000	72 000	1 465	1 020	1 020
			11								
			7								
26,5 16,5 8,5	5,5	7	26,5	5,5	7	29,3	69 000	141 000	3 610	2 485	2 485
			16,5								
			8,5								
15	5,5	7	15	5,5	7	40,5	104 000	213 000	5 600	2 730	2 730

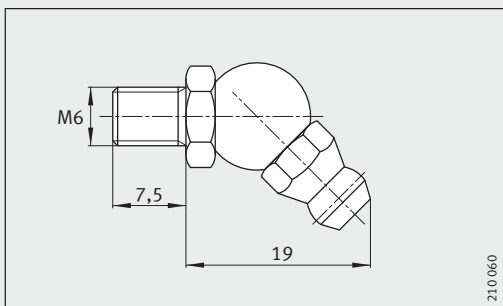
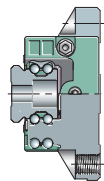

Lubrication nipple³⁾

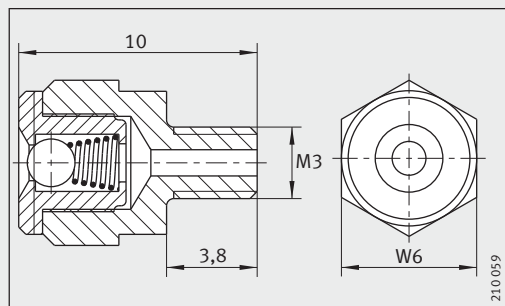

Lubrication nipple³⁾,
width across flats $W = 6$ mm

Four-row linear recirculating ball bearing and guideway assemblies

Full complement
SL, HL, SNL carriages

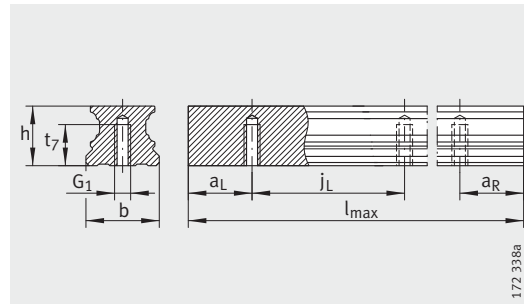

TKVD..-U

Dimension table · Dimensions in mm											
Designation	Dimensions				Dimensions						
	$l_{\max}^{1)}$	H	B	L	A_1	J_B	b <small>-0,005 -0,03</small>	A_2	L_1	J_L	j_L
KUVE20-B-SL	2 960	30	44	87,3	12	32	20	6	67,9	50	60
KUVE20-B-SNL		27									
KUVE25-B-HL	2 960	40	48	107,5	12,5	35	23	6,5	86,5	50	60
KUVE25-B-SL		36									
KUVE25-B-SNL		31									
KUVE30-B-HL	2 960	45	60	125,4	16	40	28	10	100	60	80
KUVE30-B-SL		42									
KUVE30-B-SNL		38									
KUVE35-B-HL	2 960	55	70	143,4	18	50	34	10	113	72	80
KUVE35-B-SL		48									
KUVE35-B-SNL		44									
KUVE45-B-HL	2 940	70	86	171,1	20,5	60	45	13	134,6	80	105
KUVE45-B-SL		60									
KUVE45-B-SNL		52									
KUVE55-B-SL	2 520	70	100	210	23,5	75	53	12,5	170	95	120

For further table values, see page 274 and page 275.

- 1) Maximum length of single-piece guideways. For permissible number of guideway pieces, see page 259.
Maximum single-piece guideway length of 6 m available by agreement.
- 2) a_L and a_R are dependent on the guideway length.
- 3) If there is a possibility of preload loss due to settling, the fixing screws should be secured against rotation.
- 4) ① Locating face
② Marking

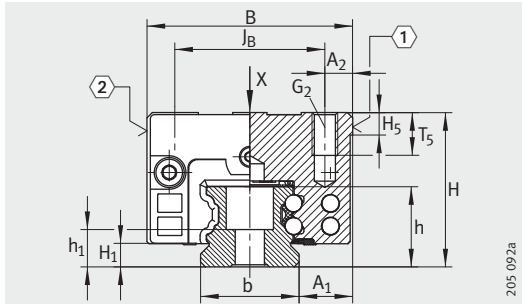

KUBE...-B (-SL, -HL, -SNL)
①, ②⁴⁾

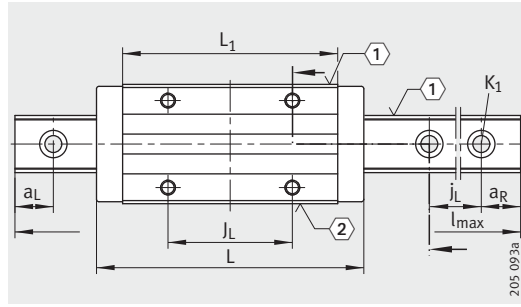

KUBE...-B (-SL, -HL, -SNL) · View rotated 90°
①, ②⁴⁾

a _L , a _R ²⁾		H ₁	H ₅	T ₅	t ₇	h	h ₁	Fixing screws ³⁾					
min.	max.							G ₁		G ₂		K ₁	
		DIN ISO 4 762-12.9											
								M _A		M _A		M _A	
								Nm		Nm		Nm	
20	53	4,5	5,25	7,5	10	17	9,1	M6	17	M5	10	M5	10
20	53	5,1	5,25	10	12	18,7	8,7	M6	17	M6	17	M6	17
				7,5									
20	71	5,9	6,25	13,5	15	23,5	11,5	M8	41	M8	41	M8	41
				11									
20	71	6,7	6,75	13,5	15	27	15	M8	41	M8	41	M8	41
20	94	9,7	9,25	17	20	34,2	16,2	M12	140	M10	83	M12	140
				16,5									
20	107	13,5	11,25	15	22	41,5	19,5	M14	220	M12	140	M14	220

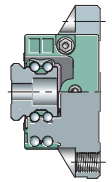

Four-row linear recirculating ball bearing and guideway assemblies

Full complement
SL, HL, SNL carriages

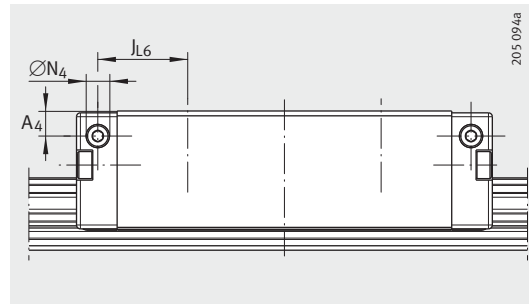

Lubrication connector on lateral face

Dimension table (continued) · Dimensions in mm

Designation	Carriage		Guideway		
	Designation	Mass m ≈kg	Designation	Mass m ≈kg/m	Closing plug K ₂
KUVE20-B-SL	KWVE20-B-SL	0,46	TKVD20 (-U)	2,2	KA10-TN/A
KUVE20-B-SNL	KWVE20-B-SNL	0,38			
KUVE25-B-HL	KWVE25-B-HL	1	TKVD25(-U)	2,7	KA11-TN/A
KUVE25-B-SL	KWVE25-B-SL	1			
KUVE25-B-SNL	KWVE25-B-SNL	0,62			
KUVE30-B-HL	KWVE30-B-HL	1,43	TKVD30(-U)	4,3	KA15-TN/A
KUVE30-B-SL	KWVE30-B-SL	1,7			
KUVE30-B-SNL	KWVE30-B-SNL	1,1			
KUVE35-B-HL	KWVE35-B-HL	2,4	TKVD35(-U)	5,7	KA15-TN/A
KUVE35-B-SL	KWVE35-B-SL	1,81			
KUVE35-B-SNL	KWVE35-B-SNL	1,72			
KUVE45-B-HL	KWVE45-B-HL	4,27	TKVD45(-U)	9,2	KA20-TN/A
KUVE45-B-SL	KWVE45-B-SL	3,38			
KUVE45-B-SNL	KWVE45-B-SNL	2,68			
KUVE55-B-SL	KWVE55-B-SL	6,3	TKVD55(-U)	14	KA24-TN/A

- 1) Calculation of basic load ratings in accordance with DIN 636.
Based on practical experience, it may be possible to increase the basic dynamic load rating.
- 2) Tapered head lubrication nipple to DIN 71 412-B M6,
KUVE20-B to DIN 71 412-B M5 and KUVE15-B to DIN 3 405-B M3, supplied loose with delivery.
- 3) Maximum permissible screw depth for lubrication connectors.

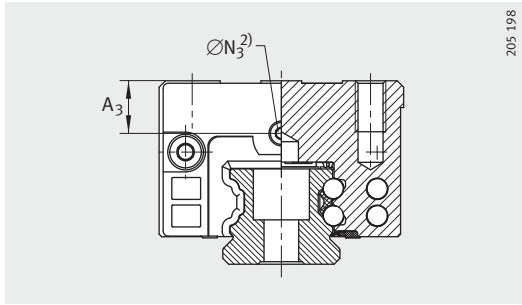

Lubrication connector on end face

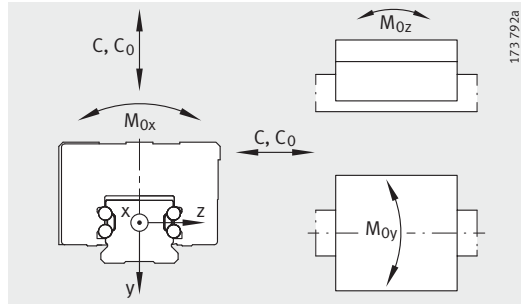

Load directions

Dimensioning of lubrication connectors						Load carrying capacity ¹⁾					
A ₃	ØN ₃		A ₄	ØN ₄		J _{L6}	Basic load ratings		Moment ratings		
		³⁾			³⁾		C N	C ₀ N	M _{0x} Nm	M _{0y} Nm	M _{0z} Nm
7,7 4,7	4,5	7	4,6	4,5	5,5	13,2	16 200	36 500	452	430	430
			3,3	2,57							
15	5,5	7	10,5	5,6	7	23,3	23 400	54 000	745	825	825
11			6,5								
6			4	2,57	6	22,5					
14,5	5,5	7	10	5,5	7	25,5	34 500	74 000	1310	1 240	1 240
11,5			7								
7,5			4,95	4,5	25,1						
19,3	5,5	7	18	5,5	7	27,5	47 500	100 000	2025	1 890	1 890
12,3			11								
8,3			7								
26,5	5,5	7	26,5	5,5	7	35,3	82 000	181 000	4 635	4 000	4 000
16,5			16,5								
8,5			8,5								
15	5,5	7	15	5,5	7	49,5	127 000	285 000	7 500	4 725	4 800

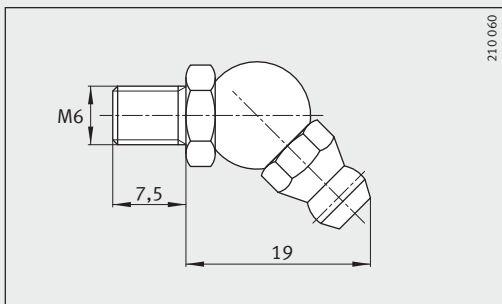
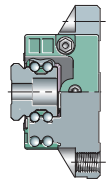

Lubrication nipple²⁾

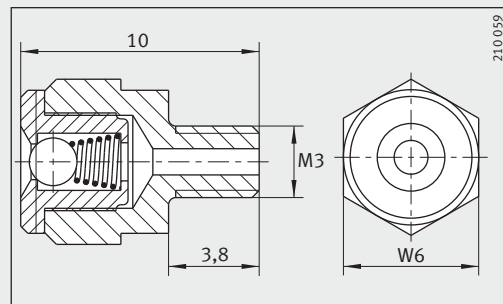

Lubrication nipple²⁾,
width across flats W = 6 mm

Four-row linear recirculating ball bearing and guideway assemblies

Full complement
EC carriages

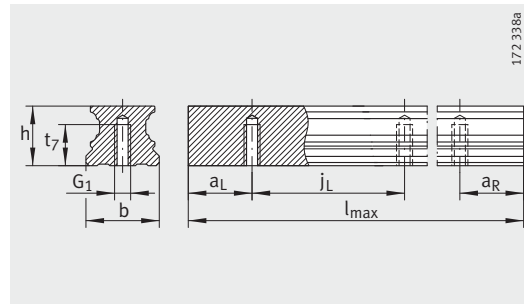

TKVD..-U

Dimension table · Dimensions in mm												
Designation	Dimensions				Mounting dimensions							
	$l_{\max}^{1)}$	H	B	L	A_1	J_B	b <small>-0,005 -0,03</small>	A_2	L_1	J_L	$a_L, a_R^{2)}$	
											min.	max.
KUVE15-B-EC	1 200	24	52	42,9	18,5	41	15	5,5	23,1	60	20	53
KUVE20-B-EC	2 960	28	59	48,8	19,5	49	20	5	29,4	60	20	53
KUVE25-B-EC	2 960	33	73	56,6	25	60	23	6,5	35,6	60	20	53
KUVE30-B-EC	2 960	42	90	67,4	31	72	28	9	42	80	20	71
KUVE35-B-EC	2 960	48	100	74,6	33	82	34	9	44,2	80	20	71
KUVE45-B-EC	2 940	60	120	96,2	37,5	100	45	10	59,7	105	20	94

For further table values, see page 278 and page 279.

- 1) Maximum length of single-piece guideways. For permissible number of guideway pieces, see page 259.
Maximum single-piece guideway length of 6 m available by agreement.
- 2) a_L and a_R are dependent on the guideway length.
- 3) If there is a possibility of preload loss due to settling, the fixing screws should be secured against rotation.
- 4) ① Locating face
② Marking

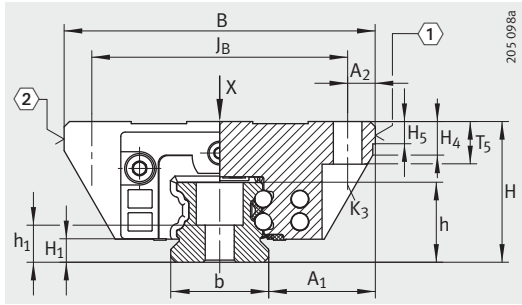

KUVE...-B-EC
 ①, ②⁴⁾

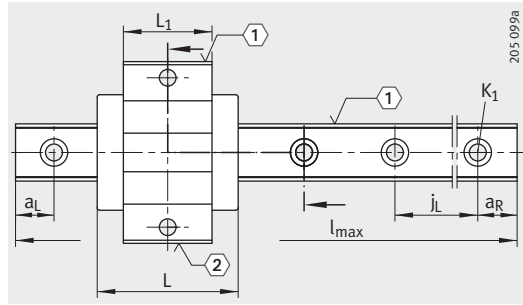

KUVE...-B-EC · View rotated 90°
 ①, ②⁴⁾

H ₁	H ₄	H ₅	T ₅	t ₇	h	h ₁	Fixing screws ³⁾					
							G ₁		K ₁		K ₃	
							DIN ISO 4 762-12.9					
						Nm		Nm		Nm		
4,3	6,1	4,75	7	8	15	8,15	M5	10	M4	5	M4	5
4,5	11,2	5,25	9	10	17	9,1	M6	17	M5	10	M5	10
5,1	7,85	5,25	10	12	18,7	8,7	M6	17	M6	17	M6	17
5,9	13,8	6,25	12	15	23,5	11,5	M8	41	M8	41	M8	41
6,7	14,3	6,75	13	15	27	15	M8	41	M8	41	M8	41
9,7	19,9	9,25	15	20	34,2	16,2	M12	140	M12	140	M10	83

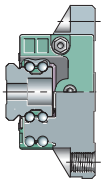

Four-row linear recirculating ball bearing and guideway assemblies

Full complement EC carriages

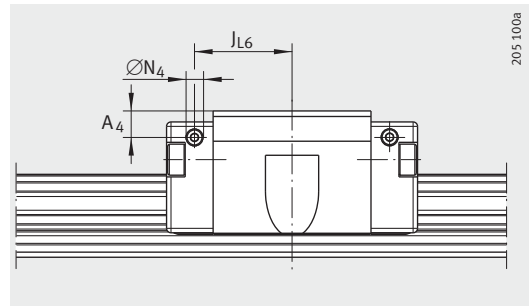

Lubrication connector on lateral face

Dimension table (continued) · Dimensions in mm

Designation	Carriage		Guideway		
	Designation	Mass m ≈kg	Designation	Mass m ≈kg/m	Closing plug K ₂
KUVE15-B-EC	KWVE15-B-EC	0,13	TKVD15-B (-U) ²⁾	1,44	KA07-TN/A
KUVE20-B-EC	KWVE20-B-EC	0,23	TKVD20 (-U)	2,2	KA10-TN/A
KUVE25-B-EC	KWVE25-B-EC	0,4	TKVD25(-U)	2,7	KA11-TN/A
KUVE30-B-EC	KWVE30-B-EC	0,75	TKVD30(-U)	4,3	KA15-TN/A
KUVE35-B-EC	KWVE35-B-EC	1,04	TKVD35(-U)	5,7	KA15-TN/A
KUVE45-B-EC	KWVE45-B-EC	2,07	TKVD45(-U)	9,2	KA20-TN/A

- 1) Calculation of basic load ratings in accordance with DIN 636.
Based on practical experience, it may be possible to increase the basic dynamic load rating.
- 2) The new carriages cannot be used on the previous guideways TKVD15(-U).
- 3) Tapered head lubrication nipple to DIN 71 412-B M6,
KUVE20-B to DIN 71 412-B M5 and KUVE15-B to DIN 3 405-B M3, supplied loose with delivery.
- 4) Maximum permissible screw depth for lubrication connectors.

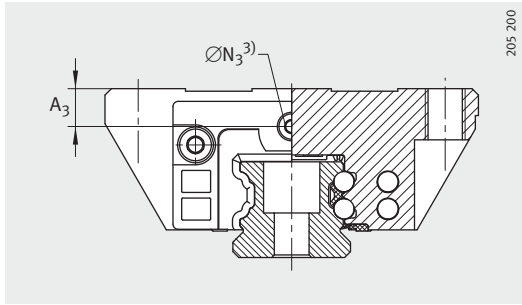

Lubrication connector on end face

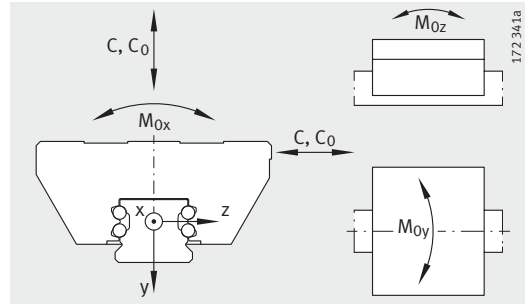

Load directions

Dimensioning of lubrication connectors							Load carrying capacity ¹⁾				
A ₃	∅N ₃		A ₄	∅N ₄		J _{L6}	Basic load ratings		Moment ratings		
		⁴⁾			⁴⁾		C N	C ₀ N	M _{0x} Nm	M _{0y} Nm	M _{0z} Nm
4,3	2,57	5,5	3,2	2,57	5,5	15,8	4 900	8 300	86	35	35
6	4,5	7	4,3	2,57	5,5	18,9	8 900	15 400	190	85	85
8	5,5	7	6	2,57	6	22	12 500	22 200	305	155	155
11,5	5,5	7	7	5,5	7	26,5	18 700	31 500	554	248	248
12,3	5,5	7	11	5,5	7	29,1	24 600	39 000	790	330	330
16,5	5,5	7	16,5	5,5	7	37,9	46 500	80 000	2 060	883	883

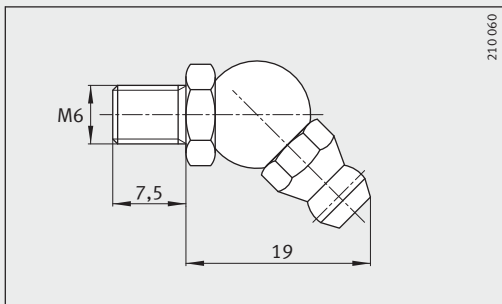
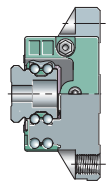

Lubrication nipple³⁾

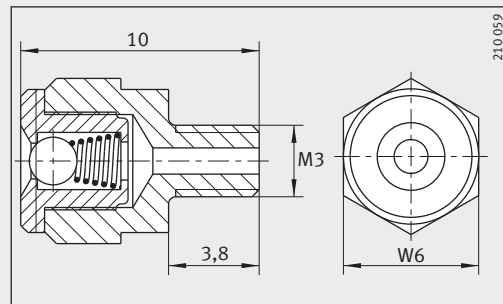

Lubrication nipple³⁾,
width across flats W = 6 mm

Four-row linear recirculating ball bearing and guideway assemblies

Full complement ESC carriages

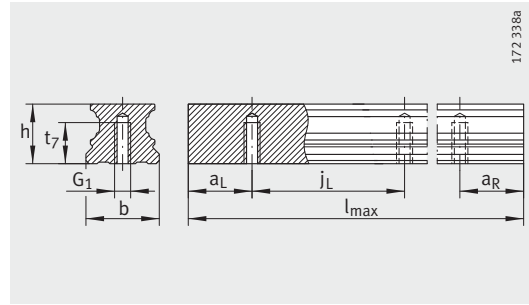

TKVD..-U

Dimension table · Dimensions in mm

Designation	Dimensions				Mounting dimensions							
	$l_{\max}^{1)}$	H	B	L	A_1	J_B	b	A_2	L_1	J_L	$a_L, a_R^{2)}$	
											min.	max.
KUVE15-B-ESC	1 200	24	34	42,9	9,5	26	15	4	23,1	60	20	53
KUVE20-B-ESC	2 960	28	42	48,8	11	32	20	5	29,4	60	20	53
KUVE25-B-ESC	2 960	33	48	56,6	12,5	35	23	6,5	35,6	60	20	53
KUVE30-B-ESC	2 960	42	60	67,4	16	40	28	10	42	80	20	71
KUVE35-B-ESC	2 960	48	70	74,6	18	50	34	10	44,2	80	20	71
KUVE45-B-ESC	2 940	60	86	96,2	20,5	60	45	13	59,7	105	20	94

For further table values, see page 282 and page 283.

¹⁾ Maximum length of single-piece guideways. For permissible number of guideway pieces, see page 259. Maximum single-piece guideway length of 6 m available by agreement.

²⁾ a_L and a_R are dependent on the guideway length.

³⁾ If there is a possibility of preload loss due to settling, the fixing screws should be secured against rotation.

⁴⁾ ① Locating face
② Marking

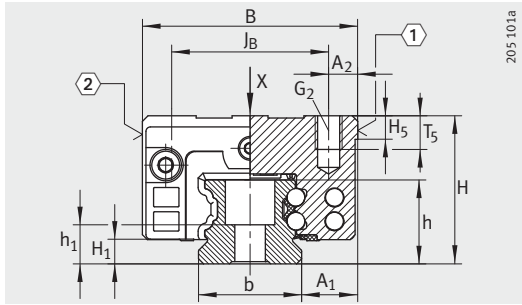

205.101a

KUVE...-B-ESC
①, ②⁴⁾

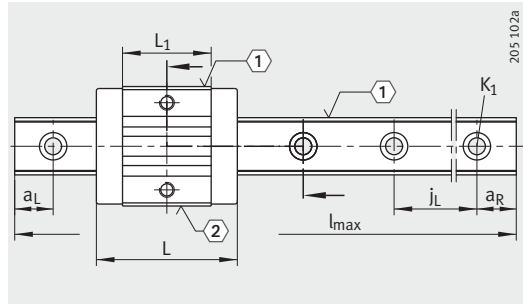

205.102a

KUVE...-B-ESC · View rotated 90°
①, ②⁴⁾

						Fixing screws ³⁾					
H ₁	H ₅	T ₅	t ₇	h	h ₁	G ₁		G ₂		K ₁	
						DIN ISO 4 762-12.9					
						M _A		M _A		M _A	
						Nm		Nm		Nm	
4,3	4,75	6	8	15	8,15	M5	10	M4	5	M4	5
4,5	5,25	7,5	10	17	9,1	M6	17	M5	10	M5	10
5,1	5,25	10	12	18,7	8,7	M6	17	M6	17	M6	17
5,9	6,25	13,5	15	23,5	11,5	M8	41	M8	41	M8	41
6,7	6,75	13,5	15	27	15	M8	41	M8	41	M8	41
9,7	9,25	17	20	34,2	16,2	M12	140	M10	83	M12	140

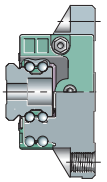

Four-row linear recirculating ball bearing and guideway assemblies

Full complement ESC carriages

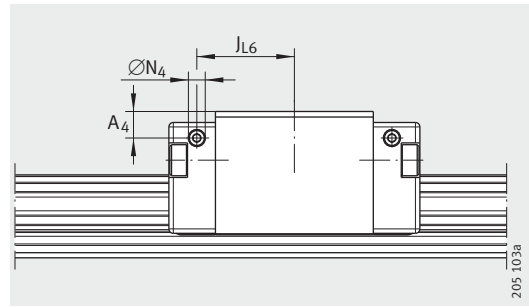

Lubrication connector on lateral face

Dimension table (continued) · Dimensions in mm

Designation	Carriage		Guideway		
	Designation	Mass m ≈kg	Designation	Mass m ≈kg/m	Closing plug K ₂
KUVE15-B-ESC	KWVE15-B-ESC	0,12	TKVD15-B (-U) ²⁾	1,44	KA07-TN/A
KUVE20-B-ESC	KWVE20-B-ESC	0,18	TKVD20 (-U)	2,2	KA10-TN/A
KUVE25-B-ESC	KWVE25-B-ESC	0,3	TKVD25(-U)	2,7	KA11-TN/A
KUVE30-B-ESC	KWVE30-B-ESC	0,57	TKVD30(-U)	4,3	KA15-TN/A
KUVE35-B-ESC	KWVE35-B-ESC	1,04	TKVD35(-U)	5,7	KA15-TN/A
KUVE45-B-ESC	KWVE45-B-ESC	1,8	TKVD45(-U)	9,2	KA20-TN/A

- 1) Calculation of basic load ratings in accordance with DIN 636.
Based on practical experience, it may be possible to increase the basic dynamic load rating.
- 2) The new carriages cannot be used on the previous guideways TKVD15(-U).
- 3) Tapered head lubrication nipple to DIN 71 412-B M6,
KUVE20-B to DIN 71 412-B M5 and KUVE15-B to DIN 3 405-B M3, supplied loose with delivery.
- 4) Maximum permissible screw depth for lubrication connectors.

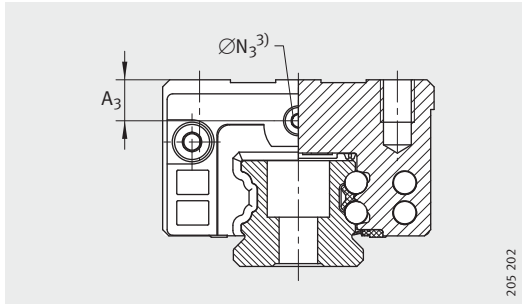

Lubrication connector on end face

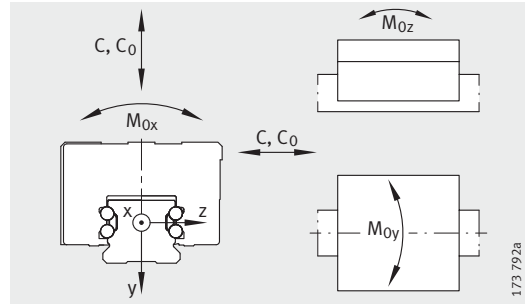

Load directions

Dimensioning of lubrication connectors							Load carrying capacity ¹⁾				
A_3	$\varnothing N_3$		A_4	$\varnothing N_4$		J_{L6}	Basic load ratings		Moment ratings		
		⁴⁾			⁴⁾		C N	C_0 N	M_{0x} Nm	M_{0y} Nm	M_{0z} Nm
4,3	2,57	5,5	3,2	2,57	5,5	15,8	4 900	8 300	86	35	35
6	4,5	7	4,3	2,57	5,5	18,9	8 900	15 400	190	85	85
8	5,5	7	6	2,57	6	22	12 500	22 200	305	155	155
11,5	5,5	7	7	5,5	7	26,5	18 700	31 500	554	248	248
12,3	5,5	7	11	5,5	7	29,1	24 600	39 000	790	330	330
16,5	5,5	7	16,5	5,5	7	37,9	46 500	80 000	2 060	883	883

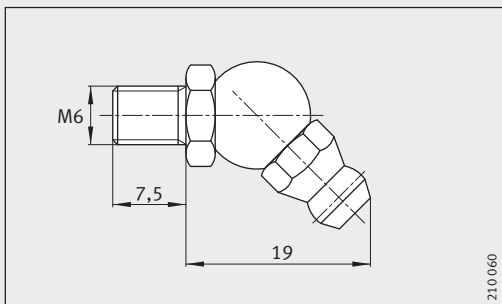
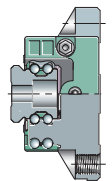

Lubrication nipple³⁾

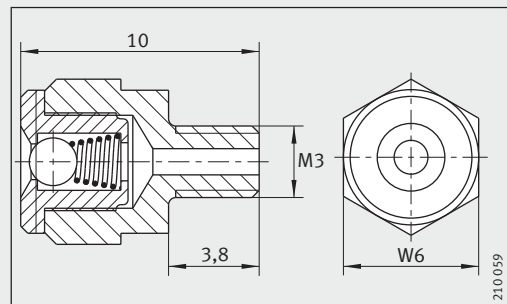

Lubrication nipple³⁾,
width across flats $W = 6$ mm

Four-row linear recirculating ball bearing and guideway assemblies

Full complement
Wide guideway
W, WL carriages

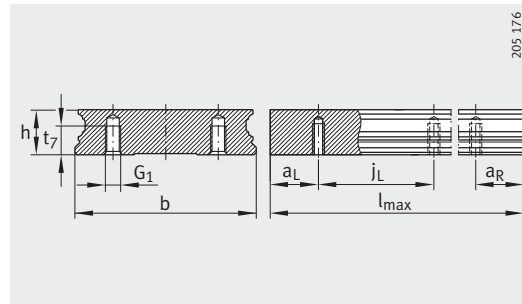

TKVD...-W-U

Dimension table · Dimensions in mm																	
Designation	Dimensions				Mounting dimensions												
	l _{max} ¹⁾	H	B	L	A ₁	J _B	j _B	a ₅	b	A ₂	L ₁	J _L	j _L	a _L , a _R ²⁾		A _{L1}	H ₁
														min.	max.		
KUVE15-W	1 200	21	68	55,6	15,5	60	22	7,5	37 ^{-0,005 -0,03}	4	39,8	29	50	10	44	1,5	4,3
KUVE20-W	1 980	27	80	69,8	19	70	24	9	42	5	50,4	40	60	20	53	19	4,6
KUVE25-WL	1 980	35	120	107,5	25,5	107	40	14,5	69	6,5	86,5	60	80	20	71	19	5,2
KUVE30-W	2 000	42	142	97,6	31	124	50	15	80	9	72	52	80	20	71	19	6
KUVE35-WL	2 960	50	162	140,2	36	144	60	15	90	9	109,8	80	80	20	71	19	6,8

1) Maximum length of single-piece guideways. For permissible number of guideway pieces, see page 259.
Maximum single-piece guideway length of 6 m available by agreement.

2) a_L and a_R are dependent on the guideway length.

3) For location from above: the maximum screw depth for the central threaded holes is T₆ + 2,5 mm.

4) If there is a possibility of preload loss due to settling, the fixing screws should be secured against rotation.

5) ① Locating face

② Marking

③ Tapered head lubrication nipple to DIN 71412-B M6,

KUVE20 to DIN 71412-B M5 and KUVE15 with drive fit lubrication nipple

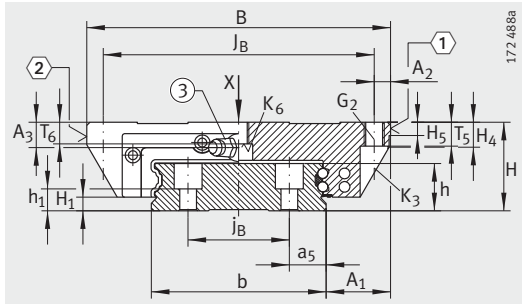

KUVE...-W (-WL)
 ①, ②, ③⁵⁾

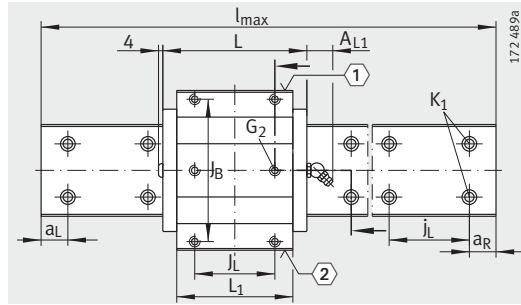

KUVE...-W (-WL) · View rotated 90°
 ①, ②⁵⁾

						Fixing screws ⁴⁾									
H ₅	H ₄	T ₅	T ₆ ³⁾	h	h ₁	G ₂		K ₁		K ₃		K ₆		K ₆	
						DIN ISO 4 762-12.9		DIN ISO 4 762-12.9		DIN ISO 4 762-12.9		DIN 7984-8.8		DIN 7984-8.8	
						M _A	M _A	M _A	M _A	M _A	M _A	M _A	M _A	M _A	M _A
						Nm	Nm	Nm	Nm	Nm	Nm	Nm	Nm	Nm	Nm
4,5	7,7	7	4,8	12,9	6	M5	5,8	M4	5	M4	5	–	–	M4	2
5	10,6	10	6	17	10	M6	10	M4	5	M5	10	–	–	M5	4
5	9,9	10	10	18,7	8,7	M8	41	M6	17	M6	17	M6	17	–	–
6	13,8	12	12	23,5	11,5	M10	41	M8	41	M8	41	–	–	M8	12
6,5	16,3	13	13	27	15	M10	41	M8	41	M8	41	M8	41	–	–

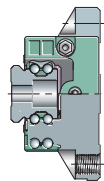

Four-row linear recirculating ball bearing and guideway assemblies

Full complement
Wide guideway
W, WL carriages

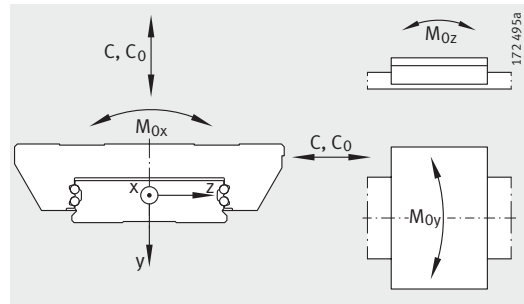

Load directions

Dimension table (continued) · Dimensions in mm

Designation	Carriage		Guideway			Load carrying capacity				
	Designation	Mass m ≈kg	Designation	Mass m ≈kg/m	Closing plug K ₂	Basic load ratings		Moment ratings		
						C N	C ₀ N	M _{0x} Nm	M _{0y} Nm	M _{0z} Nm
KUVE15-W	KWVE15-W	0,27	TKVD15-W	3,6	KA08-TN/A	7 200	14 500	332	100	100
KUVE20-W	KWVE20-W	0,5	TKVD20-W	5	KA08-TN/A	13 100	27 000	687	240	240
KUVE25-WL	KWVE25-WL	1,46	TKVD25-WL	9,4	KA11-TN/A	23 400	54 000	2 225	825	825
KUVE30-W	KWVE30-W	1,95	TKVD30-W	13,6	KA15-TN/A	27 500	55 000	2 660	700	700
KUVE35-WL	KWVE35-WL	4,11	TKVD35-W	17,4	KA15-TN/A	47 500	100 000	5 550	1 890	1 890

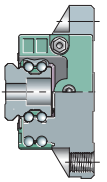

Four-row linear recirculating ball bearing and guideway assemblies

With Quad-Spacers
Standard, L carriages

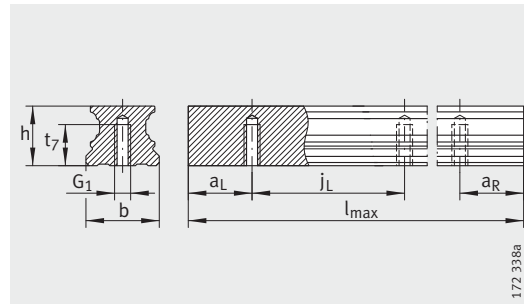

TKVD..-U

Dimension table · Dimensions in mm													
Designation	Dimensions				Mounting dimensions								
	$l_{\max}^{1)}$	H	B	L	A_1	J_B	b <small>-0,005 -0,03</small>	A_2	L_1	J_L	j_L	$a_L, a_R^{2)}$	
												min.	max.
KUVE15-B-KT	1200	24	47	59,6	16	38	15	4,5	39,8	30	60	20	53
KUVE15-B-KT-L				73									
KUVE20-B-KT	2960	30	63	69,8	21,5	53	20	5	50,4	40	60	20	53
KUVE20-B-KT-L				87,3									
KUVE25-B-KT	2960	36	70	82,1	23,5	57	23	6,5	60,7	45	60	20	53
KUVE25-B-KT-L				107,9									
KUVE30-B-KT	2960	42	90	97,4	31	72	28	9	72	52	80	20	71
KUVE30-B-KT-L				125,4									
KUVE35-B-KT	2960	48	100	110,4	33	82	34	9	80	62	80	20	71
KUVE35-B-KT-L				143,4									
KUVE45-B-KT	2940	60	120	139	37,5	100	45	10	102,5	80	105	20	94
KUVE45-B-KT-L				171,1									
KUVE55-B-KT	2520	70	140	172	43,5	116	53	12	132	95	120	20	107
KUVE55-B-KT-L				210									

For further table values, see page 290 and page 291.

- 1) Maximum length of single-piece guideways. For permissible number of guideway pieces, see page 259.
Maximum single-piece guideway length of 6 m available by agreement.
- 2) a_L and a_R are dependent on the guideway length.
- 3) If there is a possibility of preload loss due to settling, the fixing screws should be secured against rotation.
- 4) ① Locating face
② Marking

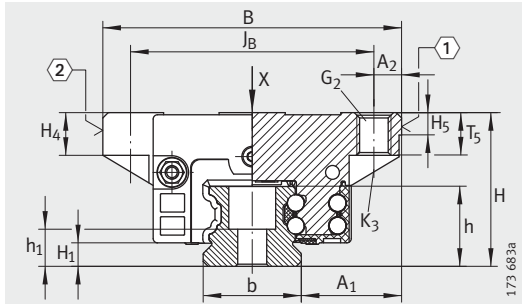

KUVE...-B-KT (-L)
①, ②⁴⁾

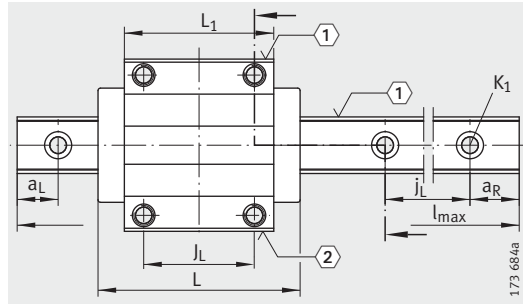

KUVE...-B-KT (-L) · View rotated 90°
①, ②⁴⁾

							Fixing screws ³⁾							
H ₁	H ₄	H ₅	T ₅	t ₇	h	h ₁	G ₁		G ₂		K ₁		K ₃	
							DIN ISO 4 762-12.9							
							M _A		M _A		M _A		M _A	
							Nm		Nm		Nm		Nm	
4,3	7	4,75	7	8	15	8,15	M5	10	M5	5,8	M4	5	M4	5
4,5	10,2	5,25	7,5	10	17	9,1	M6	17	M6	10	M5	10	M5	10
5,1	10,4	5,25	10	12	18,7	8,7	M6	17	M8	24	M6	17	M6	17
5,9	13,2	6,25	12	15	23,5	11,5	M8	41	M10	41	M8	41	M8	41
6,7	13,3	6,75	13	15	27	15	M8	41	M10	41	M8	41	M8	41
9,7	19,1	9,25	15	20	34,2	16,2	M12	140	M12	83	M12	140	M10	83
13,5	21,6	11,25	21	22	41,5	19,5	M14	220	M14	140	M14	220	M12	140

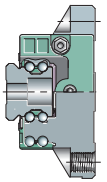

Four-row linear recirculating ball bearing and guideway assemblies

With Quad-Spacers
Standard, L carriages

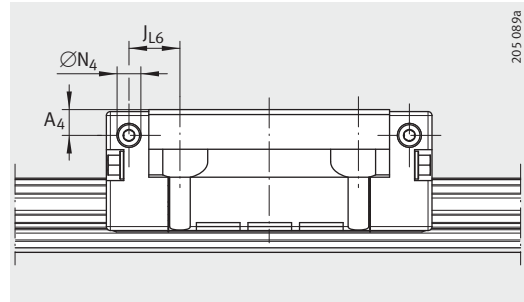

Lubrication connector on lateral face

Dimension table (continued) · Dimensions in mm

Designation	Carriage		Guideway		
	Designation	Mass m ≈kg	Designation	Mass m ≈kg/m	Closing plug K ₂
KUVE15-B-KT	KWVE15-B-KT	0,17	TKVD15-B (-U) ²⁾	1,44	KA07-TN/A
KUVE15-B-KT-L	KWVE15-B-KT-L	0,21			
KUVE20-B-KT	KWVE20-B-KT	0,37	TKVD20 (-U)	2,2	KA10-TN/A
KUVE20-B-KT-L	KWVE20-B-KT-L	0,5			
KUVE25-B-KT	KWVE25-B-KT	0,6	TKVD25(-U)	2,7	KA11-TN/A
KUVE25-B-KT-L	KWVE25-B-KT-L	0,9			
KUVE30-B-KT	KWVE30-B-KT	1	TKVD30(-U)	4,3	KA15-TN/A
KUVE30-B-KT-L	KWVE30-B-KT-L	1,5			
KUVE35-B-KT	KWVE35-B-KT	1,56	TKVD35(-U)	5,7	KA15-TN/A
KUVE35-B-KT-L	KWVE35-B-KT-L	2,16			
KUVE45-B-KT	KWVE45-B-KT	2,98	TKVD45(-U)	9,2	KA20-TN/A
KUVE45-B-KT-L	KWVE45-B-KT-L	4,3			
KUVE55-B-KT	KWVE55-B-KT	4	TKVD55-B(-U)	14	KA24-TN/A
KUVE55-B-KT-L	KWVE55-B-KT-L	6,18			

- 1) Calculation of basic load ratings in accordance with DIN 636.
Based on practical experience, it may be possible to increase the basic dynamic load rating.
- 2) The new carriages cannot be used on the previous guideways TKVD15(-U).
- 3) Tapered head lubrication nipple to DIN 71 412-B M6,
KUVE20-B to DIN 71 412-B M5 and KUVE15-B to DIN 3 405-B M3, supplied loose with delivery.
- 4) Maximum permissible screw depth for lubrication connectors.

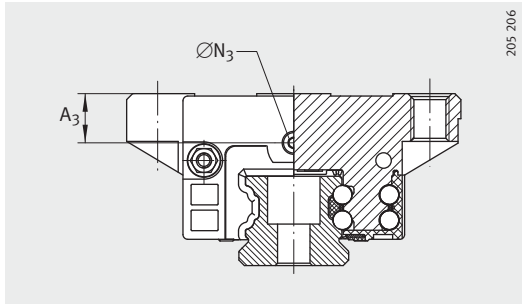

Lubrication connector on end face

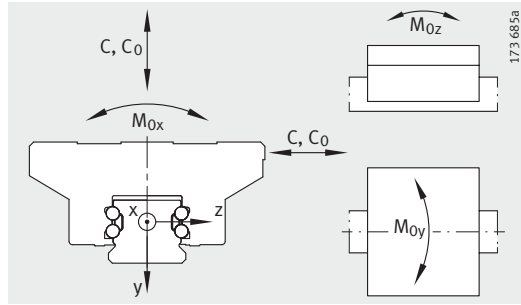

Load directions

Dimensioning of lubrication connectors						Load carrying capacity ¹⁾					
A_3	$\varnothing N_3$		A_4	$\varnothing N_4$		J_{L6}	Basic load ratings		Moment ratings		
		⁴⁾			⁴⁾		C N	C_0 N	M_{0x} Nm	M_{0y} Nm	M_{0z} Nm
4,3	2,57	5,5	3,2	2,57	5,5	9,1	6 100	11 400	105	74	74
						15,8	7 900	16 500	162	148	105
7,7	4,5	7	4,5	4,5	5,5	9,5	11 800	23 000	276	205	205
						18,3	14 400	30 500	368	345	345
11	5,5	7	6,5	5,5	7	12,9	16 200	32 000	430	330	335
						25,8	21 100	47 000	625	690	690
11,5	5,5	7	7	5,5	7	15	26 500	51 000	890	670	670
						29	33 000	71 000	1 230	1 230	1 245
12,3	5,5	7	11	5,5	7	16	36 000	67 000	1 340	995	995
						32,5	44 000	89 000	1 790	1 715	1 710
16,5	5,5	7	16,5	5,5	7	19,3	65 000	130 000	3 600	2 610	2 610
						35,3	79 000	171 000	4 715	4 335	4 330
15	5,5	7	15	5,5	7	30,5	99 000	199 000	6 730	4 750	4 750
						49,5	123 000	270 000	9 115	8 490	8 490

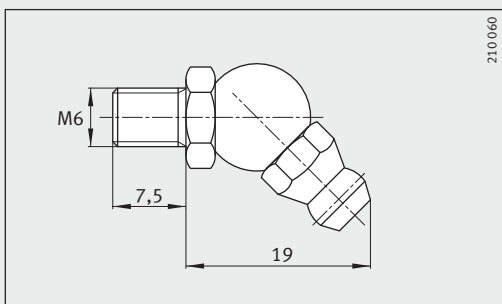
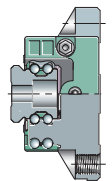

Lubrication nipple³⁾

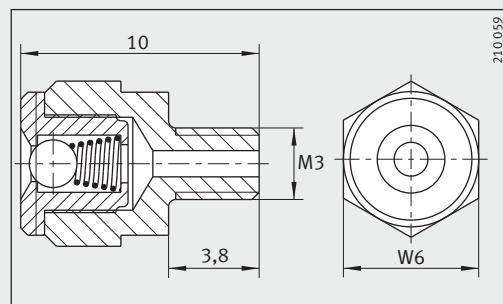

Lubrication nipple³⁾,
width across flats $W = 6$ mm

Four-row linear recirculating ball bearing and guideway assemblies

With Quad-Spacers
S, SL, H, HL carriages

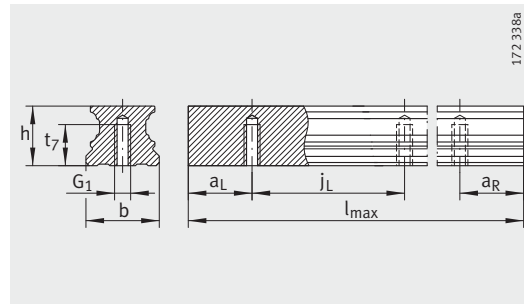

TKVD..-U

Dimension table · Dimensions in mm													
Designation	Dimensions				Mounting dimensions								
	$l_{\max}^{1)}$	H	B	L	A_1	J_B	b	A_2	L_1	J_L	j_L	$a_L, a_R^{2)}$	
							$-0,005$ $-0,03$					min.	max.
KUVE15-B-KT-S	1 200	24	34	59,6	9,5	26	15	4	39,8	26	60	20	53
KUVE15-B-KT-H		28		73					53,2				
KUVE15-B-KT-SL		24											
KUVE15-B-KT-HL		28											
KUVE20-B-KT-S	2 960	30	44	69,8	12	32	20	6	50,4	36	60	20	53
KUVE20-B-KT-SL		87,3		67,9					50				
KUVE25-B-KT-S	2 960	36	48	82,1	12,5	35	23	6,5	60,7	35	60	20	53
KUVE25-B-KT-H		40		107,9					86,5	50			
KUVE25-B-KT-SL		36											
KUVE25-B-KT-HL		40											
KUVE30-B-KT-S	2 960	42	60	97,4	16	40	28	10	72	40	80	20	71
KUVE30-B-KT-H		45		125,4					100	60			
KUVE30-B-KT-SL		42											
KUVE30-B-KT-HL		45											
KUVE35-B-KT-S	2 960	48	70	110,4	18	50	34	10	80	50	80	20	71
KUVE35-B-KT-H		55		143,4					113	72			
KUVE35-B-KT-SL		48											
KUVE35-B-KT-HL		55											
KUVE45-B-KT-S	2 940	60	86	139	20,5	60	45	13	102,5	60	105	20	94
KUVE45-B-KT-H		70		171,1					134,6	80			
KUVE45-B-KT-SL		60											
KUVE45-B-KT-HL		70											
KUVE55-B-KT-S	2 520	70	100	172	23,5	75	53	12,5	132	75	120	20	107
KUVE55-B-KT-SL		210											

For further table values, see page 294 and page 295.

- 1) Maximum length of single-piece guideways. For permissible number of guideway pieces, see page 259.
Maximum single-piece guideway length of 6 m available by agreement.
- 2) a_L and a_R are dependent on the guideway length.
- 3) If there is a possibility of preload loss due to settling, the fixing screws should be secured against rotation.
- 4) ① Locating face
② Marking

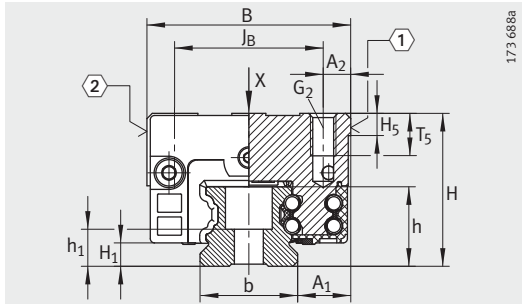

KUVE...-B-KT (-S, -SL, -H, -HL)
 ①, ②⁴⁾

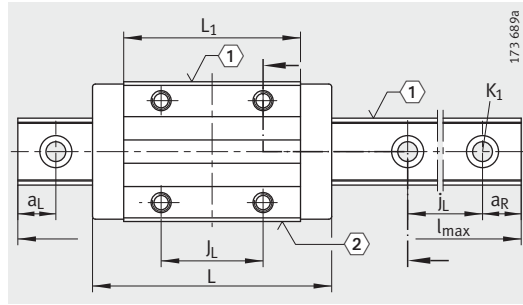

KUVE...-B-KT (-S, -SL, -H, -HL) ·
 View rotated 90°
 ①, ②⁴⁾

						Fixing screws ³⁾					
H ₁	H ₅	T ₅	t ₇	h	h ₁	G ₁		G ₂		K ₁	
						DIN ISO 4 762-12.9					
							Nm		Nm		Nm
4,3	4,75	6	8	15	8,15	M5	–	M4	5	M4	5
4,5	5,25	7,5	10	17	9,1	M6	17	M5	10	M5	10
5,1	5,25	10	12	18,7	8,7	M6	17	M6	17	M6	17
5,9	6,25	13,5	15	23,5	11,5	M8	41	M8	41	M8	41
6,7	6,75	13,5	15	27	15	M8	41	M8	41	M8	41
9,7	9,25	17	20	34,2	16,2	M12	140	M10	83	M12	140
13,5	11,25	15	22	41,5	19,5	M14	220	M12	140	M14	220

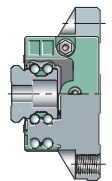

Four-row linear recirculating ball bearing and guideway assemblies

With Quad-Spacers
S, SL, H, HL carriages

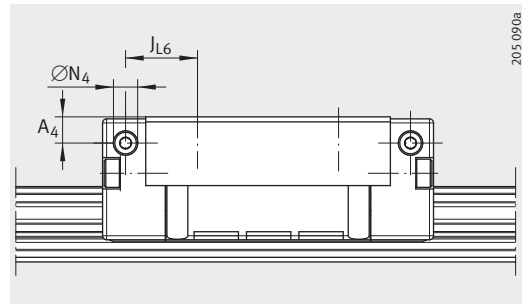

Lubrication connector on lateral face

Dimension table (continued) · Dimensions in mm

Designation	Carriage		Guideway		
	Designation	Mass m ≈kg	Designation	Mass m ≈kg/m	Closing plug K ₂
KUVE15-B-KT-S	KWVE15-B-KT-S	0,14	TKVD15-B (-U) ²⁾	1,44	KA07-TN/A
KUVE15-B-KT-H	KWVE15-B-KT-H	0,18			
KUVE15-B-KT-SL	KWVE15-B-KT-SL	0,18			
KUVE15-B-KT-HL	KWVE15-B-KT-HL	0,23			
KUVE20-B-KT-S	KWVE20-B-KT-S	0,4	TKVD20 (-U)	2,2	KA10-TN/A
KUVE20-B-KT-SL	KWVE20-B-KT-SL	0,41			
KUVE25-B-KT-S	KWVE25-B-KT-S	0,56	TKVD25(-U)	2,7	KA11-TN/A
KUVE25-B-KT-H	KWVE25-B-KT-H	0,6			
KUVE25-B-KT-SL	KWVE25-B-KT-SL	0,73			
KUVE25-B-KT-HL	KWVE25-B-KT-HL	0,85			
KUVE30-B-KT-S	KWVE30-B-KT-S	0,85	TKVD30(-U)	4,3	KA15-TN/A
KUVE30-B-KT-H	KWVE30-B-KT-H	0,95			
KUVE30-B-KT-SL	KWVE30-B-KT-SL	1,1			
KUVE30-B-KT-HL	KWVE30-B-KT-HL	1,3			
KUVE35-B-KT-S	KWVE35-B-KT-S	1,3	TKVD35(-U)	5,7	KA15-TN/A
KUVE35-B-KT-H	KWVE35-B-KT-H	1,59			
KUVE35-B-KT-SL	KWVE35-B-KT-SL	1,79			
KUVE35-B-KT-HL	KWVE35-B-KT-HL	2,23			
KUVE45-B-KT-S	KWVE45-B-KT-S	2,45	TKVD45(-U)	9,2	KA20-TN/A
KUVE45-B-KT-H	KWVE45-B-KT-H	3,14			
KUVE45-B-KT-SL	KWVE45-B-KT-SL	3,2			
KUVE45-B-KT-HL	KWVE45-B-KT-HL	4,1			
KUVE55-B-KT-S	KWVE55-B-KT-S	3,95	TKVD55-B(-U)	14	KA24-TN/A
KUVE55-B-KT-SL	KWVE55-B-KT-SL	5,05			

- 1) Calculation of basic load ratings in accordance with DIN 636.
Based on practical experience, it may be possible to increase the basic dynamic load rating.
- 2) The new carriages cannot be used on the previous guideways TKVD15(-U).
- 3) Tapered head lubrication nipple to DIN 71 412-B M6,
KUVE20-B to DIN 71 412-B M5 and KUVE15-B to DIN 3 405-B M3, supplied loose with delivery.
- 4) Maximum permissible screw depth for lubrication connectors.

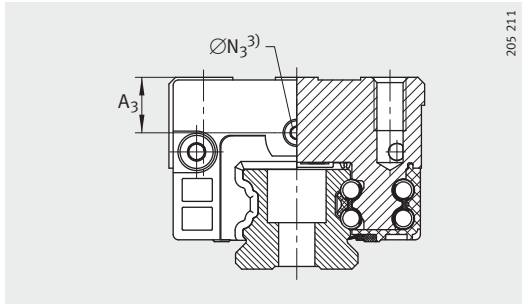

Lubrication connector on end face

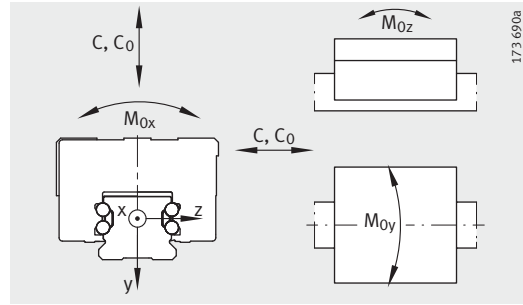

Load directions

Dimensioning of lubrication connectors						Load carrying capacity ¹⁾					
A_3	$\varnothing N_3$		A_4	$\varnothing N_4$		J_{L6}	Basic load ratings		Moment ratings		
		4)			4)		C N	C_0 N	M_{0x} Nm	M_{0y} Nm	M_{0z} Nm
4,3	2,57	5,5	3,2	2,57	5,5	11,1	6 100	11 400	105	74	74
8,3			7,2								
4,3			3,2								
8,3			7,2								
7,7	4,5	5,5	4,5	4,5	5,5	11,5	11 800	23 000	276	205	205
						13,3	14 400	30 500	368	345	345
11	5,5	7	6,5	5,5	7	17,9	16 200	32 000	430	330	335
15			10,5								
11			6,5								
15			10,5								
11,5	5,5	7	7	5,5	7	21	26 500	51 000	890	670	670
14,5			10								
11,5			7								
14,5			10								
12,3	5,5	7	11	5,5	7	22	36 000	67 000	1 340	995	995
19,3			18								
12,3			11								
19,3			18								
16,5	5,5	7	16,5	5,5	7	29,3	65 000	130 000	3 600	2 610	2 610
26,5			26,5								
16,5			16,5								
26,5			26,5								
15	5,5	7	15	5,5	7	40,5	99 000	199 000	5 230	2 530	2 560
						49,5	123 000	270 000	7 100	4 580	4 580

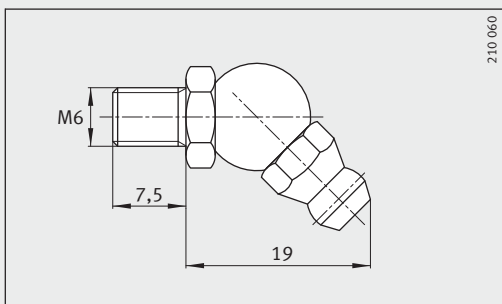
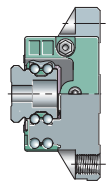

Lubrication nipple³⁾

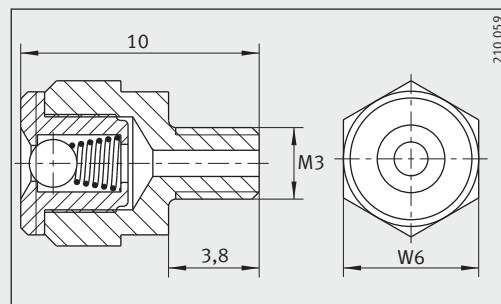

Lubrication nipple³⁾,
width across flats $W = 6$ mm